

ROBOTICS

# Product manual

## OmniCore V250XT Type B



Trace back information:  
Workspace 24A version a11  
Checked in 2024-03-05  
Skribenta version 5.5.019

**Product manual**  
**OmniCore V250XT Type B**

OmniCore

Document ID: 3HAC087112-001

Revision: B

The information in this manual is subject to change without notice and should not be construed as a commitment by ABB. ABB assumes no responsibility for any errors that may appear in this manual.

Except as may be expressly stated anywhere in this manual, nothing herein shall be construed as any kind of guarantee or warranty by ABB for losses, damage to persons or property, fitness for a specific purpose or the like.

In no event shall ABB be liable for incidental or consequential damages arising from use of this manual and products described herein.

This manual and parts thereof must not be reproduced or copied without ABB's written permission.

Keep for future reference.

Additional copies of this manual may be obtained from ABB.

Original instructions.

© Copyright 2023-2024 ABB. All rights reserved.  
Specifications subject to change without notice.



# Table of contents

Overview of this manual .....	9
Product documentation .....	11
<b>1 Safety</b> .....	<b>13</b>
1.1 Safety information .....	13
1.1.1 Limitation of liability .....	13
1.1.2 Safety data .....	14
1.1.3 Requirements on personnel .....	15
1.2 Safety signals and symbols .....	16
1.2.1 Safety signals in the manual .....	16
1.2.2 Safety symbols on controller labels .....	18
1.3 Robot stopping functions .....	21
1.3.1 Protective stop and emergency stop .....	21
1.3.2 About emergency stop .....	23
1.3.3 Enabling device and hold-to-run functionality .....	24
1.4 Robot operating modes .....	25
1.4.1 About the manual mode .....	25
1.4.2 About the automatic mode .....	27
1.5 Safety during installation and commissioning .....	28
1.6 Safety during operation .....	31
1.7 Safety during maintenance and repair .....	32
1.8 Safety during troubleshooting .....	33
1.9 Safety during decommissioning .....	34
<b>2 Controller description</b> .....	<b>35</b>
2.1 OmniCore V250XT Type B .....	35
2.2 Technical data for OmniCore V250XT Type B controller .....	36
2.3 Safety functions and safety related data for OmniCore V250XT Type B .....	43
2.4 The unit is sensitive to ESD .....	45
2.5 Handling of FlexPendant .....	47
2.6 Network security .....	48
2.7 Open source and 3rd party components .....	49
2.8 ABB Connected Services (ABB Ability) .....	50
<b>3 Installation and commissioning</b> .....	<b>53</b>
3.1 Introduction to installation and commissioning .....	53
3.2 Installation activities .....	54
3.3 Transporting and handling .....	55
3.3.1 Lifting the controller cabinet .....	55
3.3.2 Unpacking .....	56
3.3.3 Storing .....	57
3.4 On-site installation .....	58
3.4.1 Required installation space .....	58
3.4.2 Securing and stacking the controller cabinet .....	60
3.4.3 Mounting the FlexPendant holder .....	61
3.4.4 Connecting the Connected Services antenna .....	67
3.5 Electrical connections .....	69
3.5.1 Connectors on the OmniCore V250XT Type B controller .....	69
3.5.2 Connecting cables to the controller .....	72
3.5.3 Power supply system requirements .....	79
3.5.4 Connecting the manipulator to the controller .....	81
3.5.5 Fitting the connector for incoming mains .....	82
3.5.6 Connecting incoming mains and protective earth to the controller .....	84
3.5.7 Detaching and attaching a FlexPendant .....	87
3.5.8 Ethernet networks on OmniCore .....	91
3.5.9 Descriptions for connectors .....	92

# Table of contents

---

3.5.10	Configuring robot stopping functions .....	108
3.5.11	Programmable stop functions .....	111
3.6	I/O system .....	114
3.6.1	Available industrial networks .....	114
3.6.2	Scalable I/O, internal and external .....	116
3.7	Installing options .....	117
3.7.1	Installing the scalable I/O devices .....	117
3.7.2	Installing the safety digital base device .....	120
3.7.3	Installing the Ethernet extension switch .....	123
3.7.4	Installing additional drive units .....	126
3.7.5	Installing the power supply optional device .....	131
3.7.6	Installing the conveyor tracking module (CTM) .....	137
3.7.7	Installing the cable grommet assembly .....	140
3.7.8	Installing the air filter .....	146
3.7.9	Installing the mains connections cable .....	149
3.7.10	Installing the DeviceNet board .....	153
3.7.11	Installing the motor connection box .....	156
3.7.12	Installing the process cable gland process interface .....	159
3.7.13	Installing the CP/CS harness .....	161
3.8	Installing external devices .....	163
3.9	Initial test before commissioning .....	164
<b>4</b>	<b>Maintenance</b> .....	<b>165</b>
4.1	Maintenance schedule for the OmniCore controller .....	165
4.2	Inspection activities .....	166
4.2.1	Inspection of controller .....	166
4.3	Cleaning activities .....	167
4.3.1	Cleaning air filter .....	167
4.3.2	Cleaning of the controller cabinet .....	170
4.3.3	Cleaning the FlexPendant .....	171
4.4	Changing/replacing activities .....	173
4.4.1	Replacement of air filter .....	173
4.5	Function tests .....	177
4.5.1	Function test of emergency stop .....	177
4.5.2	Function test of manual, auto, and manual full speed mode with FlexPendant ....	178
4.5.3	Function test of three-position enabling device .....	179
4.5.4	Function test of safety switches .....	180
4.5.5	Function test of Automatic Stop .....	181
4.5.6	Function test of General Stop .....	182
4.5.7	Function test of external emergency stop .....	183
4.5.8	Function test of ESTOP_STATUS output .....	184
4.5.9	Function test of reduced speed control .....	185
<b>5</b>	<b>Repair</b> .....	<b>187</b>
5.1	Introduction to repair .....	187
5.2	Replacement of controller parts .....	188
5.2.1	Opening the robot controller .....	188
5.2.2	Replacing the fans .....	193
5.2.2.1	Replacing the external fans .....	194
5.2.2.2	Replacing the internal fan .....	198
5.2.2.3	Replacing the main computer fan .....	202
5.2.2.4	Replacing the power unit fan .....	206
5.2.3	Replacing the Ethernet switch (DSQC1035) .....	210
5.2.4	Replacing the 3G Connected Services gateway .....	214
5.2.5	Replacing the 4G Connected Services gateway .....	221
5.2.6	Replacing the scalable I/O unit .....	229
5.2.7	Replacing the safety digital base device .....	234
5.2.8	Replacing the main computer .....	238
5.2.9	Replacing the main computer battery .....	243

5.2.10	Replacing the power unit .....	249
5.2.11	Replacing the HVLP power unit (DSQC3072) .....	254
5.2.12	Replacing the power supply .....	259
5.2.13	Replacing the drive unit .....	267
5.2.14	Replacing the additional drive unit .....	272
5.2.15	Replacing the DeviceNet board .....	276
5.2.16	Replacing the conveyor tracking module (CTM) .....	280
5.2.17	Replacing the air filter .....	285
5.2.18	Replacing the break resistor bleeder .....	289
5.3	Replacing parts on the front panel and door .....	294
5.3.1	Replacing the manipulator signal connector (SMB) .....	294
5.3.2	Replacing the motor connector .....	297
5.3.2.1	Replacing the motor connector .....	298
5.3.3	Replacing the HMI signal (FlexPendant) connector .....	302
5.3.4	Replacing the cable grommet assembly .....	308
5.3.5	Replacing the Ethernet outlet connector with cable .....	317
5.3.6	Replacing the LED indicator .....	323
5.3.7	Replacing the door lock insert .....	327
5.4	Replacing parts on the FlexPendant .....	330
5.4.1	Replacing the power cable and power cable cover .....	330
5.4.2	Replacing the joystick protection .....	335
5.4.3	Replacing the fasten strip .....	338
5.5	Replacing other parts .....	339
5.5.1	Replacing the motor connection box .....	339
5.5.2	Replacing the measurement unit .....	341
5.5.3	Replacing the motor connection box battery .....	346
<b>6</b>	<b>Decommissioning</b> .....	<b>349</b>
6.1	Introduction to decommissioning .....	349
6.2	Environmental information .....	350
<b>7</b>	<b>Troubleshooting</b> .....	<b>353</b>
7.1	Introduction to troubleshooting .....	353
7.2	Troubleshooting fault symptoms .....	355
7.2.1	No LEDs are lit on the controller .....	356
7.2.2	Start-up failure .....	359
7.2.3	System update failure .....	362
7.2.4	Problem releasing the robot brakes .....	363
7.2.5	Problem starting or connecting the FlexPendant .....	366
7.2.6	Problem using the joystick .....	370
7.2.7	Controller fails to start .....	371
7.2.8	Reflashing firmware failure .....	372
7.2.9	Inconsistent path accuracy .....	373
7.2.10	Controller is overheated .....	375
7.3	Troubleshooting units .....	376
7.3.1	Troubleshooting LEDs in the controller .....	376
7.3.2	Troubleshooting the FlexPendant .....	377
7.3.3	Troubleshooting the drive unit .....	378
7.3.4	Troubleshooting the additional drive unit .....	384
7.3.5	Troubleshooting the power unit .....	391
7.3.6	Troubleshooting the HVLP power unit (DSQC3072) .....	398
7.3.7	Troubleshooting fieldbuses and I/O .....	404
7.3.8	Troubleshooting the 3G Connected Services gateway .....	405
7.3.9	Troubleshooting the 4G Connected Services gateway .....	411
7.3.10	Troubleshooting the Ethernet switch (DSQC1035) .....	422
7.3.11	Troubleshooting the main computer .....	424
7.3.12	Troubleshooting the process power supply .....	430
7.3.13	Troubleshooting the power supply, ODVA .....	431

# Table of contents

---

<b>8</b>	<b>Reference information</b>	<b>433</b>
8.1	Introduction .....	433
8.2	Applicable standards .....	434
8.3	Unit conversion .....	435
8.4	Standard toolkit for controller .....	436
8.5	Screw joints .....	437
8.6	Weight specifications .....	438
8.7	Lifting accessories and lifting instructions .....	439
<b>9</b>	<b>Spare parts</b>	<b>441</b>
9.1	Controller parts .....	442
9.1.1	Controller system parts .....	443
9.1.2	Mains connection parts .....	449
9.1.3	Logic parts .....	450
9.1.4	Application parts .....	453
9.1.5	Cabinet parts .....	457
9.1.6	Miscellaneous parts .....	461
9.1.7	Cables .....	467
9.2	FlexPendant parts .....	469
9.3	Manipulator cables .....	470
9.3.1	Manipulator cables .....	470
9.3.2	Customer cables - CP/CS connectors (option) .....	471
9.3.3	Customer cables - Ethernet floor cables .....	472
9.3.4	Customer cables - DeviceNet cables .....	473
	<b>Index</b>	<b>475</b>

---

# Overview of this manual

---

## About this manual

This manual contains instructions for:

- mechanical and electrical installation of the controller
- maintenance of the controller
- mechanical and electrical repair of the controller

---

## Usage

This manual should be used during:

- installation and commissioning, from lifting the product to its work site and securing it to the foundation, to making it ready for operation
- maintenance work
- repair work
- decommissioning work



### Note

It is the responsibility of the integrator to conduct a risk assessment of the final application.

It is the responsibility of the integrator to provide safety and user guides for the robot system.

---

## Who should read this manual?

This manual is intended for:

- installation personnel
- maintenance personnel
- repair personnel.

---

## Prerequisites

A maintenance/repair/installation craftsman working with an ABB robot must:

- be trained by ABB and have the required knowledge of mechanical and electrical installation/repair/maintenance work.
- be trained to respond to emergencies or abnormal situations.

---

## Product manual scope

The manual covers all variants and designs of the OmniCore V250XT Type B. Some variants and designs may have been removed from the business offer and are no longer available for purchase.

*Continues on next page*

## References



### Tip

All documents can be found via myABB Business Portal, [www.abb.com/myABB](http://www.abb.com/myABB).

Document name	Document ID
<i>Product specification - OmniCore V line</i>	3HAC074671-001
<i>Circuit diagram - OmniCore V250XT, rev 04 or later</i>	3HAC074000-008
<i>Operating manual - RobotStudio</i>	3HAC032104-001
<i>Operating manual - OmniCore</i>	3HAC065036-001
<i>Operating manual - Integrator's guide OmniCore</i>	3HAC065037-001
<i>Technical reference manual - System parameters</i>	3HAC065041-001
<i>Application manual - Functional safety and SafeMove</i>	3HAC066559-001
<i>Application manual - Connected Services</i>	3HAC028879-001
<i>Application manual - Conveyor tracking</i>	3HAC066561-001
<i>Safety manual for robot - Manipulator and IRC5 or OmniCore controller</i>	3HAC031045-001
<i>Application manual - Additional axes</i>	3HAC082287-001

## Revisions

Revision	Description
A	First edition.
B	<p>Published in release 24A. The following updates are made in this revision:</p> <ul style="list-style-type: none"> <li>Dust ledge added.</li> <li>Updated protection class of FlexPedant in section <a href="#">Protection classes on page 40</a>.</li> <li>Updated spare part number of FlexPedant in section <a href="#">FlexPendant parts on page 469</a>.</li> <li>Sections <a href="#">Line fusing on page 41</a>, <a href="#">Drive system on page 42</a> and <a href="#">Manipulator cables on page 470</a> updated with information about IRB 390 and IRB 2400.</li> <li>Installation instructions for new options added in <a href="#">Installing options on page 117</a>: motor connection box without break release buttons, process cable gland, CP/CS harness, second row of scalable I/O units.</li> <li>Instructions for replacement of lock variants (options) added in <a href="#">Replacing the door lock insert on page 327</a>.</li> <li>Information about brake current added in <a href="#">id(1384924)Troubleshooting the additional drive unit-OmniCore_en.xml</a>.</li> </ul>

---

# Product documentation

---

## Categories for user documentation from ABB Robotics

The user documentation from ABB Robotics is divided into a number of categories. This listing is based on the type of information in the documents, regardless of whether the products are standard or optional.



### Tip

All documents can be found via myABB Business Portal, [www.abb.com/myABB](http://www.abb.com/myABB).

---

## Product manuals

Manipulators, controllers, DressPack, and most other hardware is delivered with a **Product manual** that generally contains:

- Safety information.
- Installation and commissioning (descriptions of mechanical installation or electrical connections).
- Maintenance (descriptions of all required preventive maintenance procedures including intervals and expected life time of parts).
- Repair (descriptions of all recommended repair procedures including spare parts).
- Calibration.
- Troubleshooting.
- Decommissioning.
- Reference information (safety standards, unit conversions, screw joints, lists of tools).
- Spare parts list with corresponding figures (or references to separate spare parts lists).
- References to circuit diagrams.

---

## Technical reference manuals

The technical reference manuals describe reference information for robotics products, for example lubrication, the RAPID language, and system parameters.

---

## Application manuals

Specific applications (for example software or hardware options) are described in **Application manuals**. An application manual can describe one or several applications.

An application manual generally contains information about:

- The purpose of the application (what it does and when it is useful).
- What is included (for example cables, I/O boards, RAPID instructions, system parameters, software).
- How to install included or required hardware.
- How to use the application.

*Continues on next page*

- Examples of how to use the application.

---

### Operating manuals

The operating manuals describe hands-on handling of the products. The manuals are aimed at those having first-hand operational contact with the product, that is production cell operators, programmers, and troubleshooters.



# 1 Safety

## 1.1 Safety information

### 1.1.1 Limitation of liability

---

#### Limitation of liability

Any information given in this manual regarding safety must not be construed as a warranty by ABB that the industrial robot will not cause injury or damage even if all safety instructions are complied with.

The information does not cover how to design, install and operate a robot system, nor does it cover all peripheral equipment that can influence the safety of the robot system.

In particular, liability cannot be accepted if injury or damage has been caused for any of the following reasons:

- Use of the robot in other ways than intended.
- Incorrect operation or maintenance.
- Operation of the robot when the safety devices are defective, not in their intended location or in any other way not working.
- When instructions for operation and maintenance are not followed as intended.
- Non-authorized design modifications of the robot.
- Repairs on the robot and its spare parts carried out by in-experienced or non-qualified personnel.
- Foreign objects.
- Force majeure.

---

#### Spare parts and equipment

ABB supplies original spare parts and equipment which have been tested and approved for their intended use. The installation and/or use of non-original spare parts and equipment can negatively affect the safety, function, performance, and structural properties of the robot. ABB is not liable for damages caused by the use of non-original spare parts and equipment.

# 1 Safety

---

## 1.1.2 Safety data

### 1.1.2 Safety data

---

#### Prevailing standards and directives

For the use of industrial robots, regulations must be fulfilled as described in the following standards and directives:

- EN ISO 10218-1:2011
- Machinery Directive 2006/42/EC

---

#### Performance level and category

EN ISO 10218-1 requires structure category 3 and performance level *PL d* on the robot, see EN ISO 13849-1.

---

#### Risk assessment

The results of a risk assessment performed on the robot and its intended application may determine that a safety-related control system performance other than that stated in ISO 10218 is warranted for the application.

The SISTEMA/ABB FSDT libraries contains details for the safety functions.



#### Note

The safety functions are divided into two types called *Basic Safety Functions* and *Extended Safety Functions*.

---

#### Performance level data

The performance level data for the respective controller variant is presented in section [Safety functions and safety related data for OmniCore V250XT Type B on page 43](#).

### 1.1.3 Requirements on personnel

---

#### General

Only personnel with appropriate training are allowed to install, maintain, service, repair, and use the robot. This includes electrical, mechanical, hydraulics, pneumatics, and other hazards identified in the risk assessment.

Persons who are under the influence of alcohol, drugs or any other intoxicating substances are not allowed to install, maintain, service, repair, or use the robot.

The plant liable must make sure that the personnel is trained on the robot, and on responding to emergency or abnormal situations.

---

#### Personal protective equipment

Use personal protective equipment, as stated in the instructions.

# 1 Safety

## 1.2.1 Safety signals in the manual

## 1.2 Safety signals and symbols

### 1.2.1 Safety signals in the manual







#### Introduction to safety signals

This section specifies all safety signals used in the user manuals. Each signal consists of:

- A caption specifying the hazard level (DANGER, WARNING, or CAUTION) and the type of hazard.
- Instruction about how to reduce the hazard to an acceptable level.
- A brief description of remaining hazards, if not adequately reduced.

#### Hazard levels

The table below defines the captions specifying the hazard levels used throughout this manual.

Symbol	Designation	Significance
	DANGER	Signal word used to indicate an imminently hazardous situation which, if not avoided, will result in serious injury.
	WARNING	Signal word used to indicate a potentially hazardous situation which, if not avoided, could result in serious injury.
	ELECTRICAL SHOCK	Signal word used to indicate a potentially hazardous situation related to electrical hazards which, if not avoided, could result in serious injury.
	CAUTION	Signal word used to indicate a potentially hazardous situation which, if not avoided, could result in slight injury.
	ELECTROSTATIC DISCHARGE (ESD)	Signal word used to indicate a potentially hazardous situation which, if not avoided, could result in severe damage to the product.
	NOTE	Signal word used to indicate important facts and conditions.

*Continues on next page*

Symbol	Designation	Significance
	TIP	Signal word used to indicate where to find additional information or how to do an operation in an easier way.

# 1 Safety

## 1.2.2 Safety symbols on controller labels

### 1.2.2 Safety symbols on controller labels

#### Introduction to safety symbols

Both the manipulator and the controller are marked with labels containing safety symbols and important information about the product. The purpose of the labels is to ensure personal safety for all personnel handling the robot, for example during installation, service, or operation.

The safety symbols are language independent, they only use graphics. The information labels contain information in text. See [Symbols and information on labels on page 18](#).



#### Note



The safety and information labels on the product must be observed.

#### Symbols and information on labels







#### Note

The descriptions in this section are generic, the labels can contain additional information such as values.

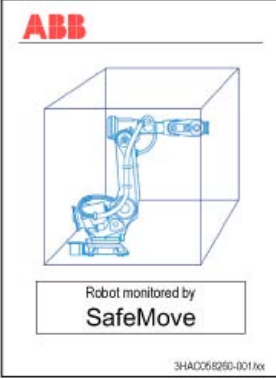
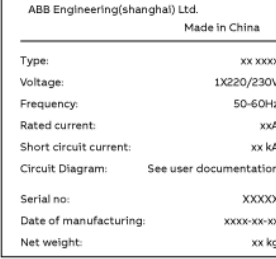
Label	Description
 xx1400001152	Read the user manual before use.
 xx1800000835	CE label

Continues on next page

Label	Description
 <p>xx1700000355</p>	<p>SafeMove label (for <i>SafeMove Basic</i> and <i>SafeMove Pro</i> software).</p>
 <p>xx1900001805</p>	<p>Rating label (example)</p>
 <p>xx1400001151</p>	<p>Electrical shock</p>
 <p>xx1800000836</p>	<p>Warning &amp; caution label</p>
 <p>xx1400001156</p>	<p>High voltage inside the module even if the main switch is in the OFF position.</p>
 <p>xx1400001162</p>	<p>ESD sensitive components inside the controller.</p>

Continues on next page

# 1 Safety

## 1.2.2 Safety symbols on controller labels

Continued

Label	Description
<div style="border: 1px solid black; padding: 5px; margin-bottom: 5px;"> <p style="text-align: center; font-size: small;">上海ABB工程有限公司</p> <hr/> <p>名称: OmniCore XXX            型号: OmniCore XXX-WIFI-LTD            CMIIT ID: XXXXXXXXXXXX</p> </div> <p>xx2300001438</p>	<p>SRRC label for WIFI (only for Chinese market)</p>
<div style="border: 1px solid black; padding: 5px; margin-bottom: 5px;"> <p style="text-align: center; font-size: small;">上海ABB工程有限公司</p> <hr/> <p>名称: OmniCore XXX            型号: OmniCore XXX-3G-LTD            CMIIT ID: XXXXXXXXXXXX</p> </div> <p>xx2300001441</p>	<p>SRRC label for 3G (only for Chinese market)</p>
<div style="border: 1px solid black; padding: 5px; margin-bottom: 5px;"> <p style="text-align: center; font-size: small;">上海ABB工程有限公司</p> <hr/> <p>名称: OmniCore V250XT            型号: OmniCore V250XT - 4G            额定电压: 3x 380-480VAC            额定频率: 50/60Hz            CMIIT ID: xxxxx</p> </div> <p>xx2300001823</p>	<p>SRRC label for 4G (only for Chinese market)</p>



## 1.3 Robot stopping functions

### 1.3.1 Protective stop and emergency stop

#### Robot stopping functions

The robot has protective and emergency stop functions (stop category 0 or 1, in accordance with IEC 60204-1).

Stop category 0	As defined in IEC 60204-1, stopping by immediate removal of power to the machine actuators.
Stop category 1	As defined in IEC 60204-1, a controlled stop with power available to the machine actuators to achieve the stop and then removal of power when the stop is achieved.

A stop function, protective or emergency stop, has a default setting for the stop category, see [Inputs to initiate a protective stop or an emergency stop on page 21](#).

The default stop category for a protective or emergency stop can be re-configured. Activation of external safety rated devices, connected to the robot controller through dedicated discrete safety inputs or safety protocols, will initiate these stop functions.

#### Inputs to initiate a protective stop or an emergency stop

Inputs to initiate a stop function	Description	Default stop category	Stop category reconfigurable
Emergency Stop (ES)	Input to initiate the emergency stop function. The <i>Emergency Stop</i> function is initiated in both automatic and manual mode.	Stop category 0 For deviations, see the product manual for the manipulator.	Yes
Automatic Stop (AS)	Input to initiate the protective stop function. <i>Automatic Stop</i> is only initiated in automatic mode.	Stop category 1 For deviations, see the product manual for the manipulator.	Yes
General Stop (GS)	Input to initiate the protective stop function. <i>General Stop</i> is initiated in both manual mode and automatic mode.	Stop category 1 For deviations, see the product manual for the manipulator.	Yes



#### Note

For OmniCore, the default configuration for the protective stop function triggered by the protective stop input is *Automatic Stop*.

For example, a safety rated output from a presence sensing device, connected to AS / GS, a dedicated discrete protective stop input on the robot controller, will when the protective stop function is configured as Automatic Stop (AS) initiate the protective stop function in automatic mode only.

*Continues on next page*

# 1 Safety

---

## 1.3.1 Protective stop and emergency stop

*Continued*

The emergency stop function is a complementary protective measure and shall not be applied as a substitute for safeguarding measures or safety functions.



### Note

For OmniCore, a safety input used to initiate a protective stop must remain active for at least 100 ms.

### Stop category configuration for OmniCore

The stop category configuration is done in RobotStudio, in the tool *Visual Safety*.

## 1.3.2 About emergency stop

---

### The emergency stop

The purpose of the emergency stop function is to avert actual or impending emergency situations arising from the behavior of persons or from an unexpected hazardous event.

The emergency stop function is to be initiated by a single human action.

The emergency stop function is a complementary protective measure and shall not be applied as a substitute for safeguarding measures and other functions or safety functions.

The effect of an activated emergency stop device is sustained until the actuator of the emergency stop device has been disengaged. This disengagement is only possible by an intentional human action on the device where the command has been initiated. The disengagement of the emergency stop device shall not restart the machinery but only permit restarting.

**Note**

The emergency stop device on the FlexPendant is operational when the robot is powered. Indicators to be used to verify that the robot is powered are the main switch on the cabinet or the LED indicator on the cabinet when robot is in Motors On Mode.

### Recover from emergency stop

- 1 Inspect the machinery in order to detect the reason for the emergency stop device actuation.
- 2 Locate and disengage the emergency stop device or devices that initiated the emergency stop function.

### 1.3.3 Enabling device and hold-to-run functionality

---

#### Three-position enabling device



#### CAUTION

The person using the three-position enabling device is responsible to observe the safeguarded space for hazards due to robot motion and any other hazards related to the robot.

The three-position enabling device is located on the FlexPendant. When continuously held in center-enabled position, the three-position enabling device will permit robot motion and any hazards controlled by the robot. Release of or compression past the center-enabled position will stop the robot motion.



#### CAUTION

For safe use of the three-position enabling device, the following must be implemented:

- The three-position enabling device must never be rendered inoperational in any way.
- If there is a need to enter safeguarded space, always bring the FlexPendant. This is to enforce single point of control.

---

#### Hold-to-run function in manual high speed mode

The hold-to-run function for manual high speed allows movement in conjunction with the three-position enabling device when the button connected to the function is actuated manually. This hold-to-run function can only be used in manual high speed mode. In case of hazard, release or compress the three-position enabling device.

How to use the hold-to-run function for manual high speed mode is described in the operating manual for the controller.

## 1.4 Robot operating modes

### 1.4.1 About the manual mode

---

#### The manual mode

Manual mode is a control state that allows for the direct control by an operator. The operator will through positioning the three-position enabling device to the center-position allow for movement of the manipulator.

There are two manual modes:

- Manual reduced speed
- Manual high speed (optional)

---

#### Safeguard mechanisms

Protective stop function initiated by

- Three-position enabling device (release of or compression past the center-enabled position)
- General Stop, GS (the dedicated input, GS, or the dedicated input AS/GS configured to GS, see actual controller)

---

#### The mode manual reduced speed

The mode manual reduced speed, is used for jogging, teaching, programming and program verification of the robot; it may be the mode selected when performing some maintenance tasks.

In manual reduced speed mode the movement of the TCP is limited to 250 mm/s. In addition, there is a limitation on the maximum allowed speed for each axis.

Manual control of the robot from inside the safeguarded space shall be performed through the FlexPendant.

**WARNING**

Wherever possible, the manual mode of operation shall be performed with all persons outside the safeguarded space.

#### Tasks normally performed in mode manual reduced speed

The following tasks are normally performed in manual reduced speed mode.

- Set or reset I/O signals
- Creating and editing RAPID programs
- Modify system parameter values
- Starting, stepping, and stopping program execution
- Jog the manipulator
- Teach or tune programmed manipulator positions

---

#### The mode manual high speed

The mode manual high speed, is used for program verification only.

*Continues on next page*

# 1 Safety

---

## 1.4.1 About the manual mode

*Continued*

The three-position enabling switch must be pressed to the center-position and the hold-to-run button must be pressed to allow start of program execution, for example, execute movement instructions.

In manual high speed, the initial speed of the movement, does not exceed 250 mm/s, that is limited to a percentage of the programmed speed. The speed can be manually adjusted in steps up to the programmed speed.

When the three-position enabling device is released or fully compressed, the speed is reset to the initial speed, that is, not exceeding 250 mm/s.



### **WARNING**

Wherever possible, the manual mode of operation shall be performed with all persons outside the safeguarded space.

Tasks normally performed in mode manual high speed

The following tasks are normally performed in manual high speed mode.

- Program verification
- Setting program pointer (to Main, to routine, to cursor, to service routine, etc.)
- Starting and stopping program execution
- Stepping program execution
- Manually adjusting speed (0–100%)

### 1.4.2 About the automatic mode

---

#### The automatic mode

Automatic mode is an operating mode in which the robot operates in accordance with the task program(s).

#### Tasks normally performed in automatic mode

The following tasks are typically performed in automatic mode:

- Start and stop of program execution.
- Increase or decrease the speed in between zero and programmed speed.
- Restore backups. Only possible when robot is at stop.
- Load, start, stop, and modify RAPID programs through remote clients.

---

#### Safeguard mechanisms

Protective stop function initiated by

- Automatic Stop, AS (the dedicated input, AS, or the dedicated input AS/GS configured to AS, see actual controller)
- General Stop, GS (the dedicated input, GS, or the dedicated input AS/GS configured to GS, see actual controller)



#### Note

Prior to allowing the robot to operate in automatic mode, ensure that any suspended safeguards, are returned to full functionality.

# 1 Safety

---

## 1.5 Safety during installation and commissioning

### 1.5 Safety during installation and commissioning

---

#### National or regional regulations

The integrator of the robot system is responsible for the safety of the robot system.

The integrator is responsible that the robot system is designed and installed in accordance with the safety requirements set forth in the applicable national and regional standards and regulations.

The integrator of the robot system is required to perform a risk assessment.

---

#### Layout

The robot integrated to a robot system shall be designed to allow safe access to all spaces during installation, operation, maintenance, and repair.

If robot movement can be initiated from an external control panel then an emergency stop must also be available.

If the manipulator is delivered with mechanical stops, these can be used for reducing the working space.

A perimeter safeguarding, for example a fence, shall be dimensioned to withstand the following:

- The force of the manipulator.
- The force of the load handled by the robot if dropped or released at maximum speed.
- The maximum possible impact caused by a breaking or malfunctioning rotating tool or other device fitted to the robot.

The maximum TCP speed and the maximum velocity of the robot axes are detailed in the section *Robot motion* in the product specification for the respective manipulator.

Consider exposure to hazards, such as slipping, tripping, and falling.

Hazards due to the working position and posture for a person working with or near the robot shall be considered.

Hazards due to noise emission from the robot needs to be considered.

Consider hazards from other equipment in the robot system, for example, that guards remain active until identified hazards are reduced to an acceptable level.

---

#### Allergenic material

See [Environmental information on page 350](#) for specification of allergenic materials in the product, if any.

---

#### Securing the robot to the foundation

The robot must be properly fixed to its foundation/support, as described in the respective product manual.

When the robot is installed at a height, hanging, or other than mounted directly on the floor, there will be additional hazards.

---

*Continues on next page*



### Using lifting accessories and other external equipment

Ensure that all equipment used during installation, service and all handling of the robot are in correct condition for the intended use.

### Electrical safety

Incoming mains must be installed to fulfill national regulations.

The power supply wiring to the robot must be sufficiently fused and if necessary, it must be possible to disconnect it manually from the mains power.

The power to the robot must be turned off with the main switch and the mains power disconnected when performing work inside the controller cabinet. Lock and tag shall be considered.

Hazards due to stored electrical energy in the controller must be considered.

Harnesses between controller and manipulator shall be fixed and protected to avoid tripping and wear.

Wherever possible, power on/off or rebooting the robot controller shall be performed with all persons outside the safeguarded space.



#### Note

Use a CARBON DIOXIDE (CO<sub>2</sub>) extinguisher in the event of a fire in the robot.

### Safety devices

The integrator is responsible for that the safety devices necessary to protect people working with the robot system are designed and installed correctly.

When integrating the robot with external devices to a robot system:

- The integrator of the robot system must ensure that emergency stop functions are interlocked in accordance with applicable standards.
- The integrator of the robot system must ensure that safety functions are interlocked in accordance with applicable standards.

### Other hazards

A robot may perform unexpected limited movement.



#### WARNING

Manipulator movements can cause serious injuries on users and may damage equipment.

The risk assessment should also consider other hazards arising from the application, such as, but not limited to:

- Water
- Compressed air
- Hydraulics

End-effector hazards require particular attention for applications which involve close human collaboration with the robot.

*Continues on next page*

# 1 Safety

---

## 1.5 Safety during installation and commissioning

*Continued*

---

### **Verify the safety functions**

Before the robot system is put into operation, verify that the safety functions are working as intended and that any remaining hazards identified in the risk assessment are mitigated to an acceptable level.

### 1.6 Safety during operation

---

#### Automatic operation

Verify the application in the operating mode manual reduced speed, before changing mode to automatic and initiating automatic operation.

---

#### Lock and change of operating mode

To prevent hazard, it is the responsibility of the integrator to make sure that keys used to lock or change the operating mode are handled only by authorized personnel.

---

#### Safety devices not in use

Safety devices that are not connected to the robot or robot system cannot initiate a protective or emergency stop. These must be stored out of sight so that they cannot be mistaken for being in use.

# 1 Safety

---

## 1.7 Safety during maintenance and repair

### 1.7 Safety during maintenance and repair

---

#### General

Corrective maintenance must only be carried out by personnel trained on the robot. Maintenance or repair must be done with all electrical, pneumatic, and hydraulic power switched off, that is, no remaining hazards.

Never use the robot as a ladder, which means, do not climb on the controller, manipulator, including motors, or other parts. There are hazards of slipping and falling. The robot might be damaged.

Make sure that there are no tools, loose screws, turnings, or other unexpected parts remaining after maintenance or repair work.

When the work is completed, verify that the safety functions are working as intended.

---

#### Hot surfaces

Surfaces can be hot after running the robot, and touching these may result in burns. Allow the surfaces to cool down before maintenance or repair.

---

#### Hazards related to batteries

Under rated conditions, the electrode materials and liquid electrolyte in the batteries are sealed and not exposed to the outside.

There is a hazard in case of abuse (mechanical, thermal, electrical) which leads to the activation of safety valves and/or the rupture of the battery container. As a result under certain circumstances, electrolyte leakage, electrode materials reaction with moisture/water or battery vent/explosion/fire may follow.

Do not short circuit, recharge, puncture, incinerate, crush, immerse, force discharge or expose to temperatures above the declared operating temperature range of the product. Risk of fire or explosion.

Operating temperatures are listed in [Operating conditions on page 39](#).

See safety instructions for the batteries in *Material/product safety data sheet - Battery pack (3HAC043118-001)*.

---

#### Related information

See also the safety information related to installation and operation.

### 1.8 Safety during troubleshooting

#### General

When troubleshooting requires work with power switched on, special considerations must be taken:

- Safety circuits might be muted or disconnected.
- Electrical parts must be considered as *live*.
- The manipulator can move unexpectedly at any time.



#### **DANGER**

Troubleshooting on the controller while powered on must be performed by personnel trained by ABB or by ABB field engineers.



#### **CAUTION**

Risk of hot surfaces that can cause burns.

A risk assessment must be done to address both robot and robot system specific hazards.

#### Related information

See also the safety information related to installation, operation, maintenance, and repair.

# 1 Safety

---

## 1.9 Safety during decommissioning

### 1.9 Safety during decommissioning

---

#### General

See section [Decommissioning on page 349](#).

If the robot is decommissioned for storage, take extra precaution to reset safety devices to delivery status.

## 2 Controller description

### 2.1 OmniCore V250XT Type B

---

#### About OmniCore V250XT Type B

The OmniCore V250XT Type B is one of the OmniCore V line controllers. OmniCore V line is a versatile and powerful controller with high degree of flexibility covering a wide range robot and applications. V line supports external axis and provides flexible configuration opportunities.

The OmniCore V250XT Type B controller offers a compact, yet flexible, solution for advanced applications and robots sizes up to IRB 6740.

## 2 Controller description

### 2.2 Technical data for OmniCore V250XT Type B controller

### 2.2 Technical data for OmniCore V250XT Type B controller

#### Overview of the controller

OmniCore V250XT Type B is intended to be used in industrial environment.

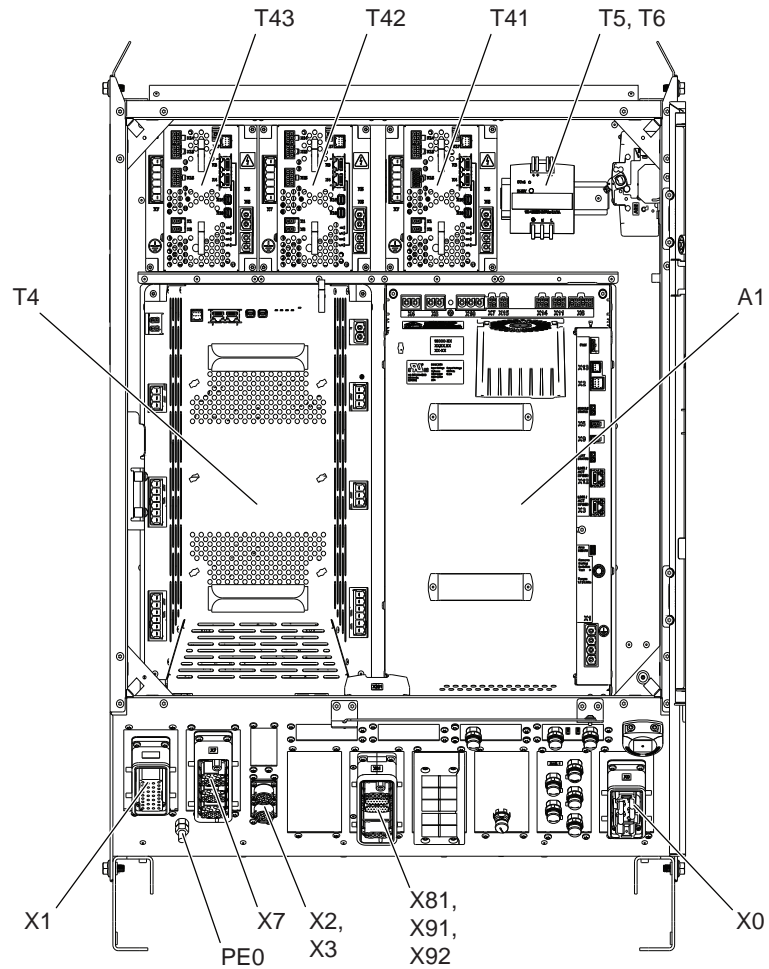

xx2300001958

*Continues on next page*



## 2 Controller description

### 2.2 Technical data for OmniCore V250XT Type B controller

*Continued*

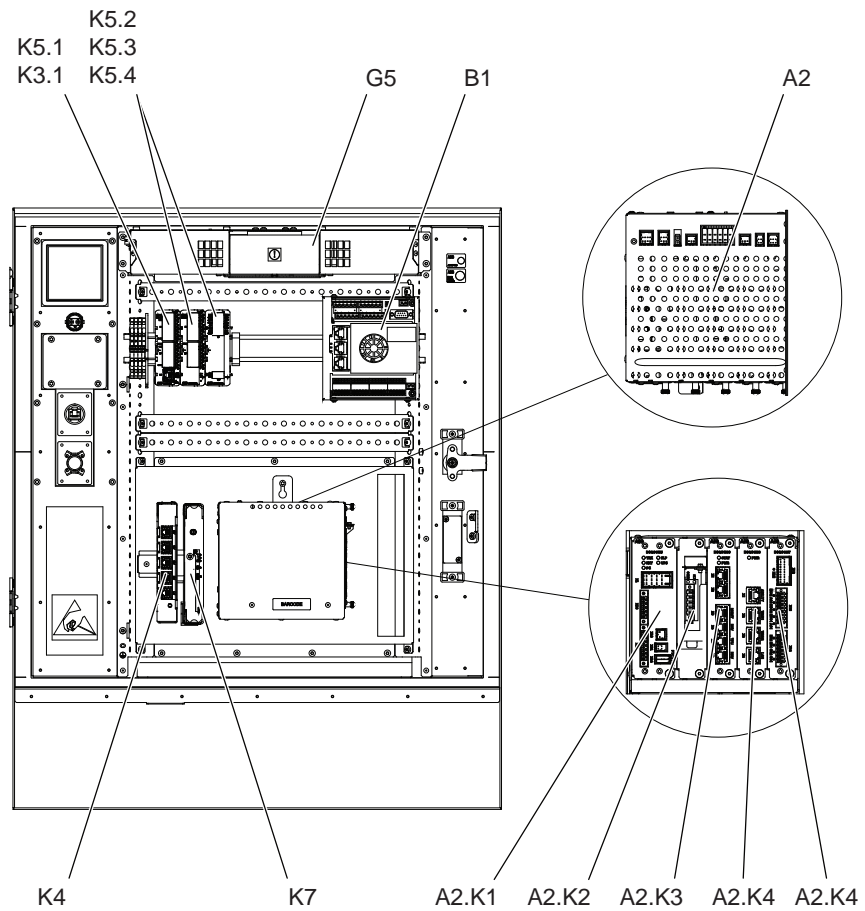

xx2300001959

#### OmniCore V250XT Type B, Baseline

Unit	Reference to circuit diagram	OmniCore V250XT Type B
Drive unit, High Voltage DSQC3062	T4	Baseline
Power unit HVHP DSQC3070	A1	Baseline
Power unit LVHP DSQC3069	A1	Baseline
Power unit HVLP DSQC3072	A1	Baseline
Manipulator signal connector (SMB)	X2, X3	Baseline
FlexPendant connector (HMI)	X4	Baseline
Motor connector	X1	Baseline
External fan	G1-G2	Baseline
Internal fan	G5	Baseline

*Continues on next page*

## 2 Controller description

### 2.2 Technical data for OmniCore V250XT Type B controller

Continued

Unit	Reference to circuit diagram	OmniCore V250XT Type B
Main computer DSQC1095	A2	Baseline
Power distribution board DSQC1085	A2.K1	Baseline
Processor board DSQC1086	A2.K3	Baseline
Ethernet switch DSQC1088	A2.K4	Baseline
Safety board DSQC1087	A2.K5	Baseline
Incoming mains switch	Q0	Baseline
Incoming mains connector	X0	Baseline
Connected Services Gateway (with antenna for 3G/4G and WiFi)	K7	Baseline <sup>i</sup>

<sup>i</sup> Default is 4G EU, 4G US, 3G, Wired or WiFi available as option.

#### OmniCore V250XT Type B, Options

Unit	Reference to circuit diagram	OmniCore V250XT Type B
Scalable I/O	K5.1	Option
Additional I/O	K5.2 K5.3 K5.4	Option
Safety digital base I/O	K3.1	Option
Conveyor tracking module	B1	Option
Ethernet switch	K4	Option
Process power supply	T5, T8	Option
ODVA power supply	T6, T9	Option
Air filter		Option
Incoming mains cable gland	X0	Option
Additional drive unit DSQC3065	T41-T43	Option
DeviceNet	A2.K2	Option
Customer power/customer signal (CP/CS)	X81	Option

#### Type label

The type label shows the type designation of this specific OmniCore controller:



xx2300001754

Continues on next page

## 2 Controller description

### 2.2 Technical data for OmniCore V250XT Type B controller *Continued*

#### Dimensions

Parameter	Value
Width	650 mm
Depth	480 mm
Height	960 mm

#### Weight

Controller	Weight
OmniCore V250XT Type B	85 kg



#### Note

The weight does not include any mounting kits fitted on the controller.

#### Transportation and storage conditions

Parameter	Value
Minimum ambient temperature	-40 °C (-40 °F)
Maximum ambient temperature	+55 °C (+131 °F)
Maximum ambient temperature (less than 24 hrs)	+70 °C (+158 °F)
Shock and Vibration	In accordance with ETSI EN 300 019-2-2 / Environmental class 2.3 (No severity reduction for horizontal axes)
	Max. 5 g = 50 m/s <sup>2</sup> (11 ms)

After storage, the operating conditions inside the controller must be met for at least 6 hours before switching on the controller (see [Operating conditions on page 39](#)).

The robot controller shall be stored according to its IP classification (IP54), that is, indoors, in an environment that is dry and dust-free. In addition, wind, temperature fluctuations, and condensation shall be avoided.

See also *Product specification - OmniCore V line*.

#### Operating conditions

The table shows the allowed operating conditions for the controller.

Parameter	Value
Minimum ambient temperature	+5 °C (+41 °F)
Maximum ambient temperature	+45 °C (+113 °F)
Maximum ambient altitude	2,000 m
Shock and Vibration	In accordance with ETSI EN 300 019-2-3 / Environmental class 3.5 (3M5) (Random vibration)

*Continues on next page*

## 2 Controller description

### 2.2 Technical data for OmniCore V250XT Type B controller

Continued



#### Note

The humidity conditions shall apply with the environmental conditions EN 60721-3-3, climatic class 3K3. For temperatures 0-30 °C, the relative humidity must not exceed 85%. For temperatures exceeding 30 °C, the absolute humidity must not exceed 25g/m<sup>3</sup>.

If the environmental conditions in EN 60721-3-3, climatic class 3K3, are not possible to meet at the installation site, desiccant bags can be placed inside the controller to achieve corresponding conditions. The desiccant bags must be replaced regularly to maintain approved operating conditions.

### Protection classes

	Protection class (IEC 60529)
Controller cabinet, inner compartment for electronics	IP54
Controller cabinet, compartment including cooling channel	IP23
FlexPendant	IP65

The cabinet must be closed and sealed when no internal access is required.

If the cabinet is not properly closed and sealed (door and cable grommets), it does not comply with the protection class (IP54) and may affect the following:

- The electromagnetic compatibility (EMC) is affected
- Units inside the cabinet are exposed to dust or moisture. Especially important in cases with high heat and humidity, or much pollution.



#### Note

To comply with IP54, all openings to the controller cabinet must be sealed. This includes unconnected connectors which must be fitted with covers.

### Airborne noise level

Data	Description	Note
Airborne noise level	The sound pressure level one meter away from each surface of the controller.	Controller in Motors On Mode: < 65 dB(A) Leq Controller in Standby Mode: < 60 dB(A) Leq

### Power supply

Mains	Value
Voltage for OmniCore V250XT Type B	380 VAC-480 VAC, 3-phase
Voltage tolerance	+10%, -15%
Frequency	50/60 Hz
Frequency tolerance	±3%

Continues on next page

Mains	Value
Short circuit current rating	According to rating label.   <b>Note</b> For installations according to UL requirements, short circuit current rating is 5 kA.



#### Note

If the controller is to be installed where the specified voltage (see table above) is not available, the customer is required to provide an external transformer.

### Line fusing

As baseline there is no integrated fuse or circuit breaker. The option 3008-3 Mains connector/Fuse includes an integrated circuit breaker.

The following table shows the recommended rating for an external circuit breaker. The values cover a configuration with a manipulator and the maximum number of additional drive units.

Robot	Voltage (V)	Current (A)
IRB 390	380 VAC-480 VAC, 3-phase	3x16 A
IRB 460	380 VAC-480 VAC, 3-phase	3x25 A
IRB 660	380 VAC-480 VAC, 3-phase	3x25 A
IRB 2400	380 VAC-480 VAC, 3-phase	3x16 A
IRB 2600	380 VAC-480 VAC, 3-phase	3x16 A
IRB 4600	380 VAC-480 VAC, 3-phase	3x25 A
IRB 5710	380 VAC-480 VAC, 3-phase	3x25 A
IRB 5720	380 VAC-480 VAC, 3-phase	3x25 A
IRB 6650S	380 VAC-480 VAC, 3-phase	3x25 A
IRB 6660	380 VAC-480 VAC, 3-phase	3x25 A
IRB 6700	380 VAC-480 VAC, 3-phase	3x25 A
IRB 6710	380 VAC-480 VAC, 3-phase	3x25 A
IRB 6720	380 VAC-480 VAC, 3-phase	3x25 A
IRB 6730	380 VAC-480 VAC, 3-phase	3x25 A
IRB 6740	380 VAC-480 VAC, 3-phase	3x25 A



#### Note

For details about installations according to UL requirements, see [Connecting incoming mains and protective earth to the controller on page 84](#).

Continues on next page

## 2 Controller description

### 2.2 Technical data for OmniCore V250XT Type B controller

*Continued*

#### Residual current

An external earth fault protection (residual current device, RCD) is required. For detailed information on how to select an external earth fault protection, see [Connecting incoming mains and protective earth to the controller on page 84](#).



#### Note

The integrator is responsible to address local electrical requirements.

#### Drive system

The drive system provides motion power and absorbs excess braking energy when the robot is running.

There is a label for the drive system on the controller. The label contains the specific drive system type information, so the label will vary according to the drive system type.



xx2300001437

The controller drive system shall only be used with specified manipulator variant. The following table shows the mapping list.

Manipulator	Controller	Drive system type
IRB 2600 or smaller	OmniCore V250XT Type B	E4 E5
IRB 4600 or larger	OmniCore V250XT Type B	E8 E9



#### Note

Controllers with different drive systems are not interchangeable.

## 2.3 Safety functions and safety related data for OmniCore V250XT Type B

### Overview

The OmniCore V250XT Type B provides safety with structure *category 3* with performance level *d* according to EN ISO 13849-1. This fulfils the safety performance requirement as stated in the robot safety standard EN ISO 10218-1.

The safety data is valid for the Basic Safety Functions and extended safety functions for applicable ABB manipulators. The supported manipulators are listed in *Product specification - OmniCore V line*.

For configuration of basic safety functions, see *Application manual - Functional safety and SafeMove, 3HAC066559-001*.



#### Note

When additional drive units are installed, the PFH<sub>D</sub> value shall be increased by 4.29E-08 for each drive.

For detailed information, see [Basic Safety Functions on page 43](#) and [Extended Safety Functions on page 43](#).

### Basic Safety Functions

Description	PFH <sub>D</sub> [1/hour]
Emergency stop function of the robot initiated by emergency stop device on the FlexPendant	2.58E-07
Protective stop function of the robot initiated by three-position enabling device on the FlexPendant	2.58E-07
Mirror emergency stop state of the robot through emergency status output of the controller	8.58E-08
Emergency stop function of the robot initiated by external emergency stop device attached to emergency stop inputs of the controller	2.58E-07
Automatic stop function of the robot initiated by external protective stop device attached to automatic stop inputs of the controller	2.58E-07
General stop function of the robot initiated by external protective stop device attached to general stop inputs of the controller	2.58E-07

### Extended Safety Functions

For extended safety functions, see *Application manual - Functional safety and SafeMove, 3HAC066559-001* and the corresponding application manual for protocols PROFINET/PROFIsafe and EtherNet/IP, CIP safety.

Description	PFH <sub>D</sub> [1/hour]
Emergency stop which can be initiated through a safety protocol.	2.58E-07
Protective stops which can be initiated through a safety protocol.	2.58E-07
Axis position supervision	2.58E-07
Axis speed supervision	2.58E-07

*Continues on next page*

## 2 Controller description

---

### 2.3 Safety functions and safety related data for OmniCore V250XT Type B

*Continued*

Description	PFH <sub>D</sub> [1/hour]
Tool position supervision	2.58E-07
Tool speed supervision	2.58E-07
Tool orientation supervision	2.58E-07
Stand still supervision	2.58E-07

---

#### Related information

[Safety data on page 14](#)

The SISTEMA/ABB FSDT libraries contain details for the safety functions.



## 2.4 The unit is sensitive to ESD

---

### Description

ESD (electrostatic discharge) is the transfer of electrical static charge between two bodies at different potentials, either through direct contact or through an induced electrical field. When handling parts or their containers, personnel not grounded may potentially transfer high static charges. This discharge may destroy sensitive electronics.

### Safe handling

Use one of the following alternatives:

- Use a wrist strap. The wrist strap button is located inside the controller.  
Wrist straps must be tested frequently to ensure that they are not damaged and are operating correctly.
- Use an ESD protective floor mat.  
The mat must be grounded through a current-limiting resistor.
- Use a dissipative table mat.  
The mat should provide a controlled discharge of static voltages and must be grounded.

*Continues on next page*

## 2 Controller description

---

### 2.4 The unit is sensitive to ESD

*Continued*

---

#### Wrist strap button

The location of the wrist strap button is shown in the following illustration.

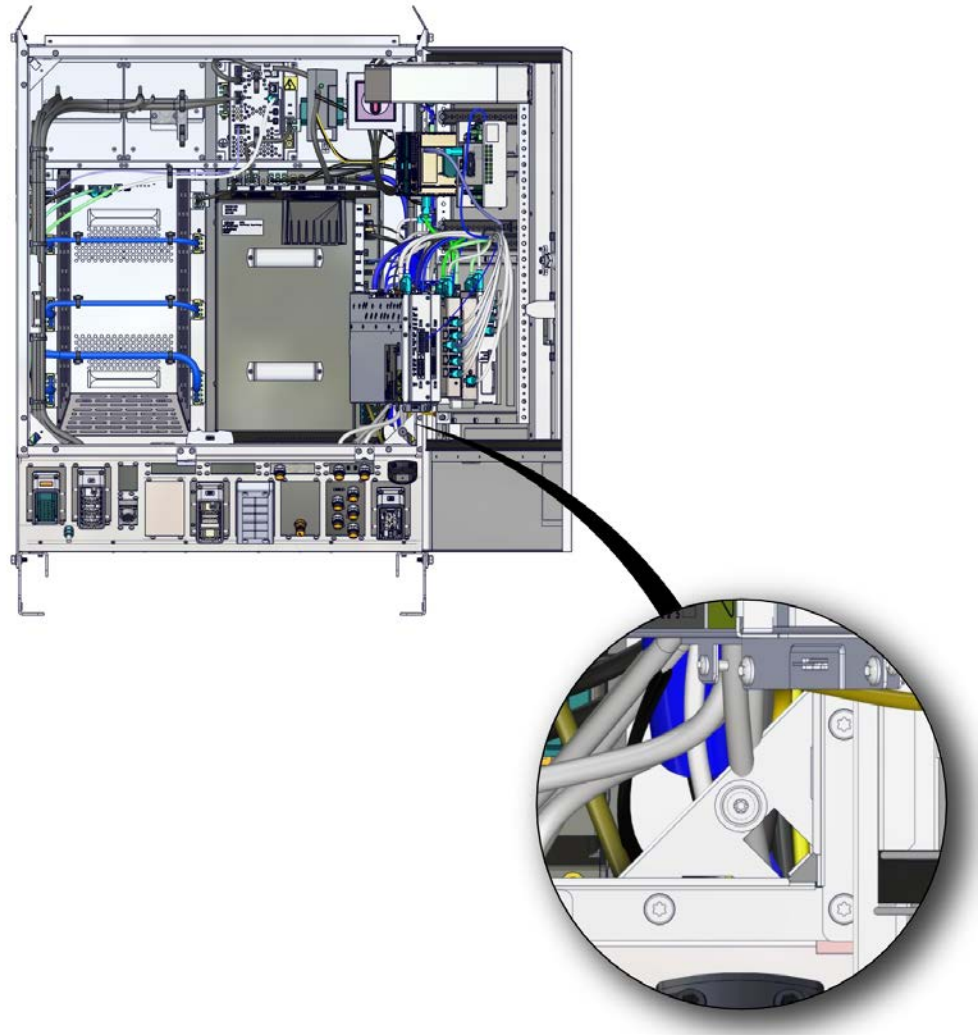

xx2200001817

## 2.5 Handling of FlexPendant

### Detached FlexPendant

A FlexPendant that is not connected to the robot must be stored out of sight so that it cannot be mistaken for being in use.

### Handling and cleaning

- The FlexPendant may only be used for the purposes mentioned in this manual.
- Always use the hand-strap while holding the FlexPendant.
- Handle with care. Do not drop, throw, or give the FlexPendant strong shock. It can cause breakage or failure.
- If the FlexPendant is subjected to shock, always verify that the safety functions (three-position enabling device and emergency stop) work and are not damaged.
- Always use and store the FlexPendant in such a way that the cable does not become a tripping hazard.
- When not using the device, place it in its holder.
- Never use sharp objects (such as screwdriver or pen) for operating the touch screen. This could damage the touch screen. Instead use your finger or a stylus.
- Never clean the FlexPendant with solvents, scouring agent, or scrubbing sponges.  
See the product manual for the robot controller, section *Cleaning the FlexPendant*.
- Always close the protective cap on the USB port when no USB device is connected. The port can break or malfunction if exposed to dirt or dust.
- Do not squeeze and thus damage the cable.
- Do not lay the cable over sharp edges.



#### CAUTION

The FlexPendant touch screen is made of glass. If the device is dropped on a hard surface or receives a significant impact the glass could break. To reduce the risk of cuts if the glass chips or cracks, do not touch or attempt to remove the broken glass.

### FCC statement

Changes or modification to the FlexPendant not expressly approved by ABB will void the user's authority to operate the equipment.

This device complies with Part 15 of the FCC Rules. Operation is subject to the following two conditions:

- 1 This device may not cause harmful interference, and
- 2 This device must accept any interference received, including interference that may cause undesired operation.

## 2 Controller description

---

### 2.6 Network security

### 2.6 Network security

---

#### Network security

This product is designed to be connected to and to communicate information and data via a network interface. It is your sole responsibility to provide, and continuously ensure, a secure connection between the product and to your network or any other network (as the case may be).

You shall establish and maintain any appropriate measures (such as, but not limited to, the installation of firewalls, application of authentication measures, encryption of data, installation of anti-virus programs, etc) to protect the product, the network, its system and the interface against any kind of security breaches, unauthorized access, interference, intrusion, leakage and/or theft of data or information. ABB Ltd and its entities are not liable for damage and/or loss related to such security breaches, any unauthorized access, interference, intrusion, leakage and/or theft of data or information.

## 2.7 Open source and 3rd party components

---

### Open source and 3rd party components

ABB products use software provided by third parties, including open source software. The following copyright statements and licenses apply to various components that are distributed inside the ABB software. Each ABB product does not necessarily use all of the listed third party software components. Licensee must fully agree and comply with these license terms or the user is not entitled to use the product. Start using the ABB software means accepting also referred license terms. The third party license terms apply only to the respective software to which the license pertains, and the third party license terms do not apply to ABB products. With regard to programs provided under the GNU general public license and the GNU lesser general public license licensor will provide licensee on demand, a machine-readable copy of the corresponding source code. This offer is valid for a period of three years after delivery of the product.

ABB software is licensed under the ABB end user license agreement, which is provided separately.

---

### RobotWare

For RobotWare, there is license information in the folder \licenses in the RobotWare distribution package.

### OpenSSL

This product includes software developed by the OpenSSL Project for use in the OpenSSL Toolkit. (<http://www.openssl.org/>)

This product includes cryptographic software written by Eric Young ([eay@cryptsoft.com](mailto:eay@cryptsoft.com)).

This product includes software written by Tim Hudson ([tjh@cryptsoft.com](mailto:tjh@cryptsoft.com)).

---

### CTM

For OleOS, the Linux based operating system used on the conveyor tracking module (CTM), a list of copyright statements and licenses is available in the file `/etc/licenses.txt` located on the CTM board and accessible via the console port or by downloading the file over SFTP.

For the CTM application, a list of copyright statements and licenses is available in the file `/opt/ABB.com/ctm/licenses.txt` located on the CTM board and accessible via the console port or by downloading the file over SFTP.

## 2 Controller description

---

### 2.8 ABB Connected Services (ABB Ability)

### 2.8 ABB Connected Services (ABB Ability)



#### Note

The content of this section is only available in English.



#### Note

ABB Connected Services is the new name for the functionality previously known as ABB Ability. During a period of time, both names will appear in and on our products.

---

The OmniCore™ controller hardware is delivered with a standard mobile connection (Cellular data connection), or WIFI modem and/or Ethernet connection.

---

#### Cellular data connection

If the ABB Connected Services™ OmniCore™ controller hardware is delivered together with a standard, free of charge (machine-to-machine or M2M) cellular data connection, it will automatically establish a connection to the ABB Connected Services™ digital platform once the power switch of the ABB Connected Services™ OmniCore™ controller hardware has been turned on and has been connected. After the establishment of the connection there will be a data flow from the OmniCore™ controller hardware to the ABB Connected Services™ digital platform.

ABB does not warrant or guarantee an available, stable, uninterrupted, and interference free connection through the standard cellular data connection. This is dependent on the availability and quality of the cellular data signal as provided by the telecommunications carrier on the location where the ABB Connected Services™ OmniCore™ hardware is installed. The cellular data connection is to be used solely in connection with the ABB Connected Services™ OmniCore™ controller hardware and excludes, without limitation, voice services, web browsing, music downloading and other services that are not traditionally considered as machine to machine (M2M), but human-oriented telecommunication services.

ABB has established and maintains a formal information and cybersecurity procedures which includes commercially reasonable technical and organizational measures, in order to protect the data against security breaches, accidental or unlawful destruction, loss, alteration, and unauthorized disclosure of, or access to the data.

The cellular data connection is not required for the operation of the hardware and the connectivity settings can be adjusted and turned off at any given time. Detailed information on the mobile connection is further described in the service description that can be downloaded from the following web location:

<https://share.library.abb.com/api/v4?cid=9AAC910011&dk=Manual>

*Continues on next page*

### FCC statement



#### Note

This equipment has been tested and found to comply with the limits for a Class A digital device, pursuant to part 15 of the FCC Rules.

These limits are designed to provide reasonable protection against harmful interference when the equipment is operated in a commercial environment.

This equipment generates, uses, and can radiate radio frequency energy and, if not installed and used in accordance with the instruction manual, may cause harmful interference to radio communications.

Operation of this equipment in a residential area is likely to cause harmful interference in which case the user will be required to correct the interference at his own expense.

Operation is subject to the following conditions:

(1) This device may not cause harmful interference, and (2) this device must accept any interference received, including interference that may cause undesired operation.

Changes or modifications not expressly approved by ABB could void the user's authority to operate the equipment under FCC rules. When the optional connectivity module is installed, the operating conditions must be such that there is a minimum separation distance of 20 cm between the dedicated antenna and nearby persons or other antennas. An intentional radiator may be operated only with the antenna which it is authorized for and accepted by ABB.

The product may be equipped with a connectivity module for 3G or for Wi-Fi as an option.

The product may be equipped with a connectivity module for 4G or for Wi-Fi as an option.

- The 3G option contains FCC ID: XMR201510UC20 by courtesy of Quectel
- The 4G option contains FCC ID: XMR201909EC21AUX by courtesy of Quectel
- The Wi-Fi option contains FCC ID: Z64-WL18SBMOD by courtesy of Texas Instruments

ABB legal contacts for FCC:

John Bubnikovich, ABB Robotics, 1250 Brown Road, Auburn Hills, MI 48326 USA,  
john.bubnikovich1@us.abb.com

Ed Marchese, ABB Robotics, 1250 Brown Road, Auburn Hills, MI 48326 USA,  
ed.marchese@us.abb.com

*Continues on next page*

## 2 Controller description

---

### 2.8 ABB Connected Services (ABB Ability)

*Continued*

---

#### Data

ABB will not acquire any right, title and interest in the data other than the rights granted by Customer to ABB, but ABB will have the right to collect, store, aggregate, analyze or otherwise use the data for (i) providing and maintaining the hardware, services and/or the ABB software to Customer; (ii) preventing, detecting and repairing problems related to the security and/or the operation of the hardware, the platform, software; (iii) improving and developing existing services, technologies, products and/or software and developing new services, technologies, products and/or software, and all improvements and developments (including all resulting intellectual property Rights) are exclusively owned by us. In addition, we have the right to use the data for benchmarking purposes if and to the extent it is anonymized or non-confidential.

---

#### ABB Connected Services™

For as far as the robot installation includes ABB Connected Services™, this agreement is entered pursuant to and governed by the ABB Connected Services™ General Terms and Conditions.

ABB Connected Services™ Terms and Conditions:

<https://ability.abb.com/terms>

Special Terms and Conditions for ABB Connected Services™:

<https://new.abb.com/products/robotics/service/robot-registration>



## 3 Installation and commissioning

### 3.1 Introduction to installation and commissioning

#### General

This chapter contains assembly instructions and information for installing the OmniCore V250XT Type B at the working site.

See also the product manual for the manipulator.

The installation must be done by qualified installation personnel in accordance with the safety requirements set forth in the applicable national and regional standards and regulations.

The technical data is detailed in section [Technical data for OmniCore V250XT Type B controller on page 36](#).

#### Safety information

Before any installation work is commenced, all safety information must be observed. There are general safety aspects that must be read through, as well as more specific safety information that describes the danger and safety risks when performing the procedures. Read the chapter [Safety on page 13](#) before performing any installation work.



#### Note

Always connect the OmniCore V250XT Type B and the robot to protective earth and residual current device (RCD) before connecting to power and starting any installation work.

## 3 Installation and commissioning

### 3.2 Installation activities

### 3.2 Installation activities

#### Main steps for installing the controller

Use the following main steps to install and connect the controller.

	Action	Described in
1	Unpack the controller.	<a href="#">Unpacking the controller on page 56.</a>
2	Place the controller in position and bolt it to the ground.	<a href="#">On-site installation on page 58.</a>
3	Connect the manipulator to the controller.	<a href="#">Connecting the manipulator to the controller on page 81.</a>
4	Attach the FlexPendant to the controller.	<a href="#">Attaching the FlexPendant on page 90</a>
5	Install an external circuit breaker or fuse.	<a href="#">Connecting incoming mains and protective earth to the controller on page 84</a>
6	Connect the cabinet to protective earth.	<a href="#">Connecting incoming mains and protective earth to the controller on page 84</a>
7	Install a residual current device (RCD).	<a href="#">Connecting incoming mains and protective earth to the controller on page 84</a>
8	Connect incoming mains to the controller.	<a href="#">Connecting incoming mains and protective earth to the controller on page 84</a>
9	Connect safeguards to the controller.	Connector X14.
10	Connect, for example, Ethernet, PC, and other connections.	How to connect industrial networks, for example PROFINET, is described in the respective application manual. How to connect to a network and a PC is described in section <a href="#">Ethernet networks on OmniCore on page 91</a> . See also <i>Operating manual - RobotStudio</i> . See also <a href="#">Descriptions for connectors on page 92</a> .
11	Connect the antenna for Connected Services.	<a href="#">Connecting the Connected Services antenna on page 67.</a>
12	Install options and add-ons (optional).	<a href="#">Installing options on page 117.</a>
13	Initial test before commissioning.	<a href="#">Initial test before commissioning on page 164.</a>



#### Note

If the controller replaces another OmniCore controller, see *Operating manual - Integrator's guide OmniCore* for descriptions of how to transfer software configurations.

## 3.3 Transporting and handling

### 3.3.1 Lifting the controller cabinet

#### Lifting device

Use the four lifting eyes or a forklift when lifting the controller, as shown below. The following figure shows the maximum angle between the lifting straps when lifting the controller. The weight of the controller module is detailed in section [Weight on page 39](#).

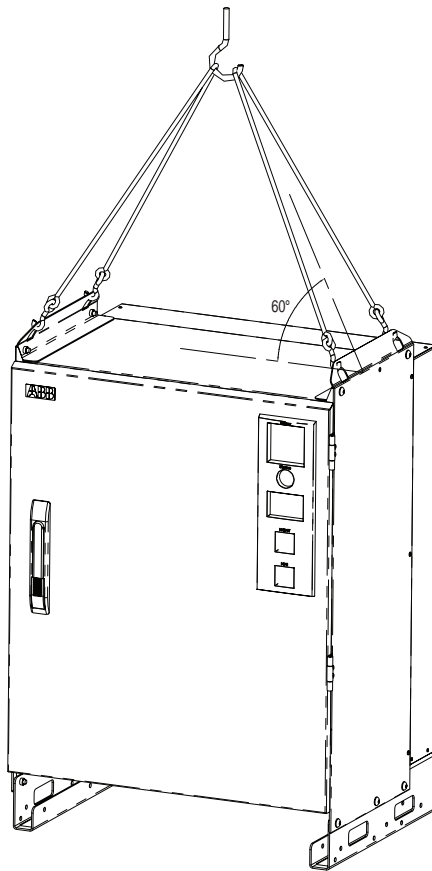

xx2100000343



#### WARNING

When lifting and transporting the cabinet using a forklift, the cabinet door must be closed to avoid tilting.



#### WARNING

Stacked cabinets must be lifted separately. Use a suitable lifting accessory to avoid injury to personnel!

For more information about stacked cabinets, see [Securing and stacking the controller cabinet on page 60](#).

## 3 Installation and commissioning

---

### 3.3.2 Unpacking

### 3.3.2 Unpacking

---

#### Unpacking the controller

	Action
1	Make a visual inspection of the packaging and make sure that nothing is damaged.
2	Remove the packaging.
3	Check for any visible transport damage.  <b>Note</b> Stop unpacking and contact ABB if transport damage is found.
4	Clean the unit with a lint-free cloth, if necessary.
5	Make sure that the lifting accessory used (if applicable) is suitable to handle the weight of the controller.
6	If the controller is not installed directly, it must be stored as described in <a href="#">Transportation and storage conditions on page 39</a> .
7	Make sure that the expected operating environment of the controller conforms to the specifications as described in <a href="#">Operating conditions on page 39</a> .
8	The controller can be taken to its installation site as described in section <a href="#">On-site installation on page 58</a> .

### 3.3.3 Storing

---

#### Storing the controller

For storing, see [Transportation and storage conditions on page 39](#).

### 3 Installation and commissioning

---

#### 3.4.1 Required installation space

### 3.4 On-site installation

#### 3.4.1 Required installation space

---

##### Dimensions

The following illustration shows the required installation space for the OmniCore V250XT Type B controller.

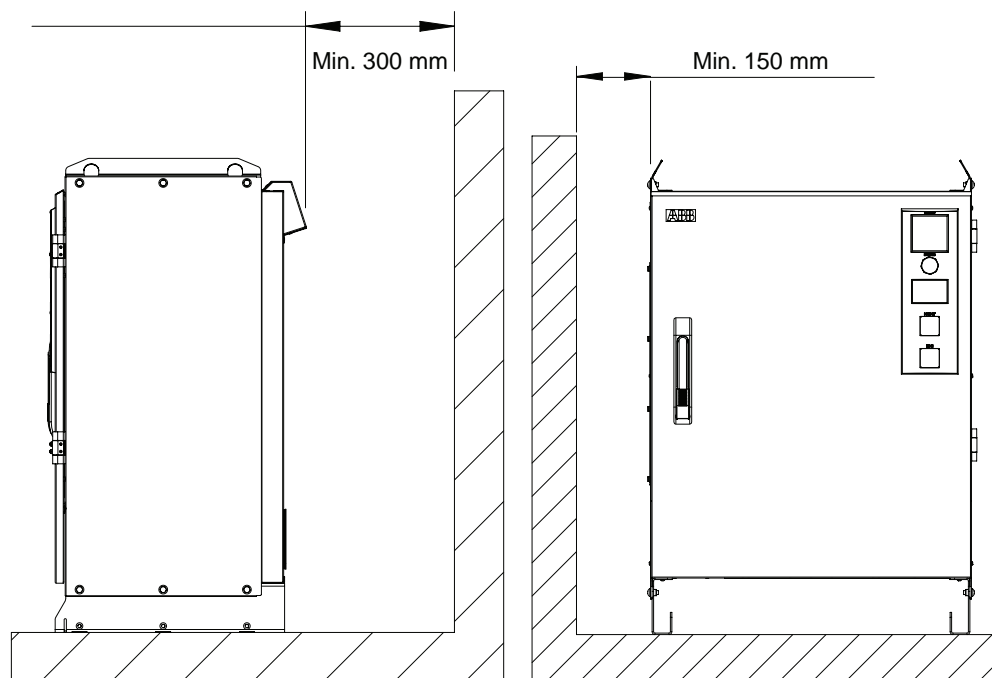

xx2200001824

- A free space of 300 mm on the back of the controller is required.
- A free space of 150 mm on the sides of the controller is required.

*Continues on next page*



#### Note

For service activities inside the cabinet, space is needed in front of the cabinet so the door can be fully opened.

For service activities such as cleaning and replacement of controller filters, a free space of 500 mm is required on one side of the controller.

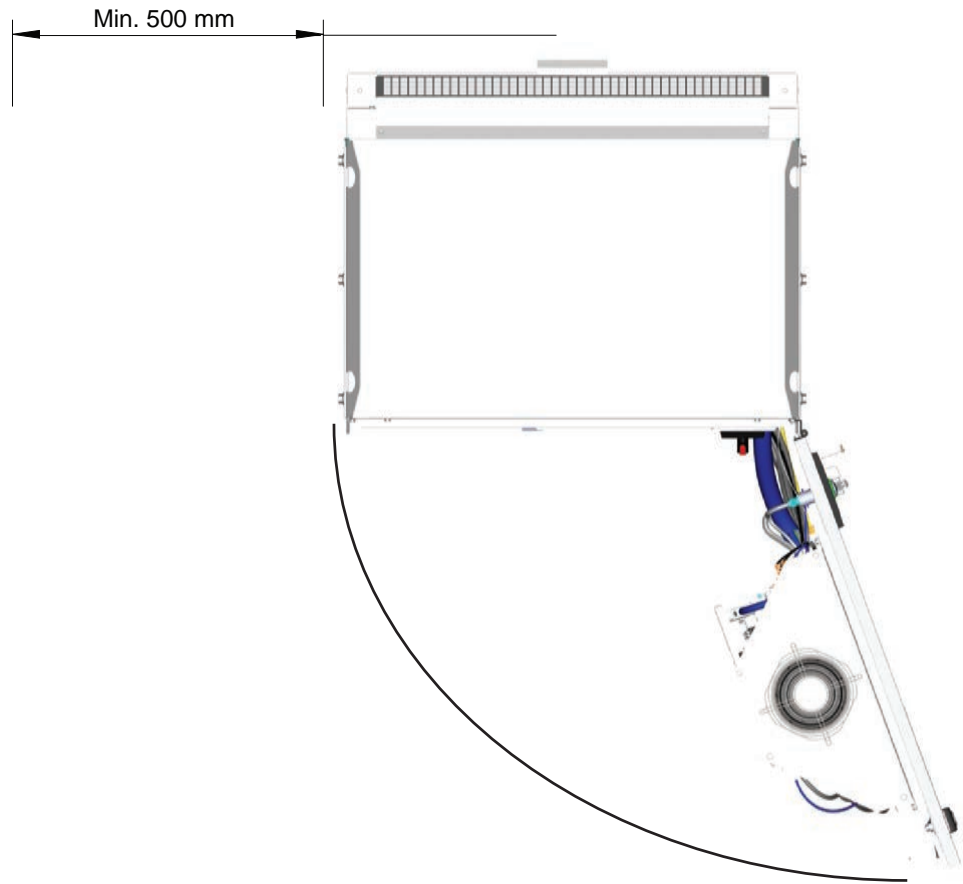

xx2200001742

## 3 Installation and commissioning

### 3.4.2 Securing and stacking the controller cabinet

#### 3.4.2 Securing and stacking the controller cabinet

##### Securing the controller

The controller can be secured to the ground. The figure below shows the bolt pattern for the OmniCore V250XT Type B controller. The diameter of the four bolt holes are 14 mm.

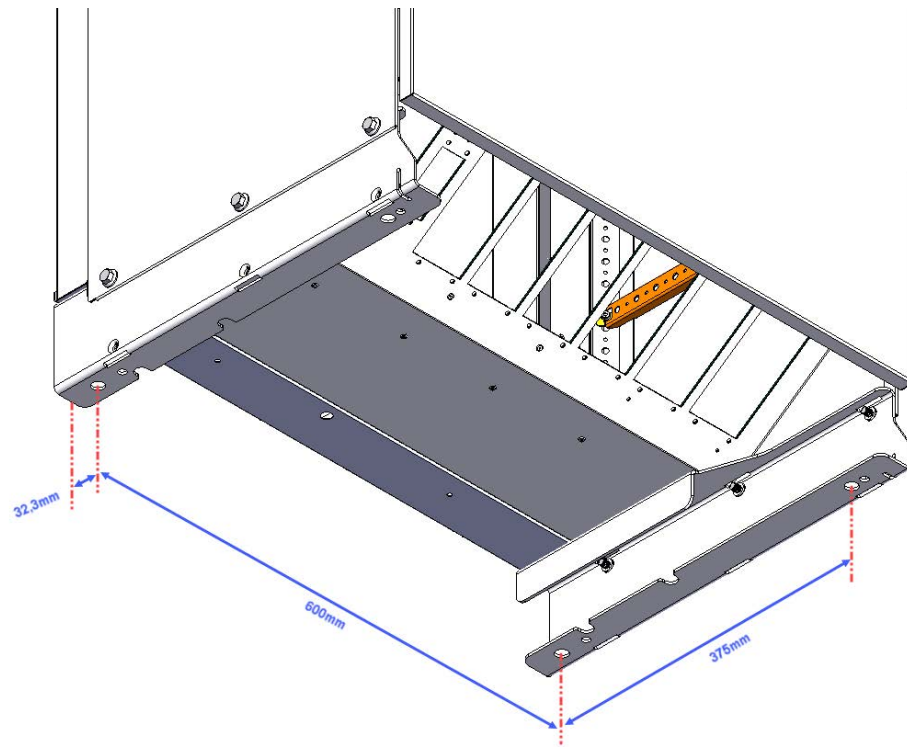

xx2200001823

##### Stacking the controller

The OmniCore V250XT Type B controller is designed so that a maximum of two controllers can be stacked. The controllers must be safely fixed to each other, and it must be assured that the opened door on the upper controller does not cause imbalance.



##### CAUTION

The stacked cabinets must be secured to the floor accordingly.



##### Note

For lifting restrictions regarding stacked cabinets, see [Lifting the controller cabinet on page 55](#).



### 3.4.3 Mounting the FlexPendant holder



#### Note

To avoid dropping the FlexPendant from height, the holder should be placed in a comfortable working height.

Always use and store the FlexPendant in such a way that the cable does not become a tripping hazard.

When not using the device, place it so it does not accidentally fall.

#### Required equipment

Equipment	Spare part number	Note
Standard toolkit		See <a href="#">Standard toolkit for controller on page 436</a> .
TPU Holder asm	3HAC079391-001	



#### Note

The FlexPendant should always be placed in the holder when it is not used and it is not allowed to use by unauthorized person.

#### Mounting the bracket for the emergency stop on the FlexPendant holder

The FlexPendant holder is shipped without the bracket for the emergency stop assembled to the holder. They are separated as two parts.

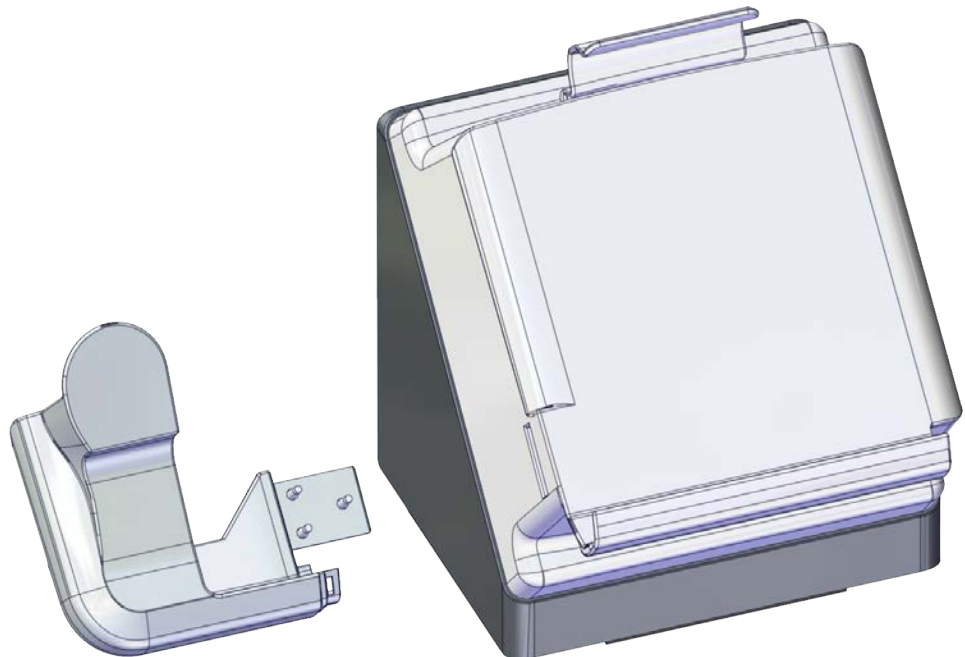

xx2100000767



*Continues on next page*

### 3 Installation and commissioning

#### 3.4.3 Mounting the FlexPendant holder

*Continued*

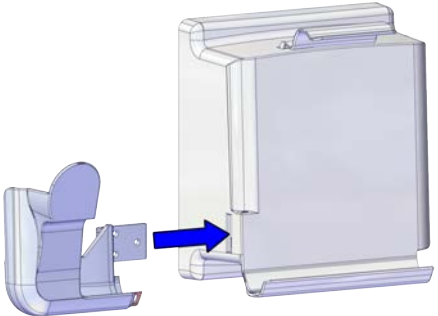
Use this procedure to mount the bracket for the emergency stop to the FlexPendant holder.

	Action	Note/illustration
1 2	Remove the four screws. Separate the rear part from the FlexPendant holder.	 <p>xx2000002356</p>
3	Insert the bracket into the FlexPendant holder.	 <p>xx2100000765</p>
4	Secure with the screws.	<p>Screws: BN33 Phillips pan head tapping screw ST2.9x13 (3 pcs) Tightening torque: 6 Nm-7.8 Nm</p>  <p>xx2100000766</p>

*Continues on next page*

### 3 Installation and commissioning

#### 3.4.3 Mounting the FlexPendant holder

*Continued*

	Action	Note/illustration
5	Refit the rear part and secure with the screws.	<p>Screws: BN33 Phillips pan head tapping screw ST3.5x16 (4 pcs) Tightening torque: 9.4 Nm-12.2 Nm</p>  <p>xx2000002356</p>

#### Mounting the FlexPendant holder onto a flat surface (Horizontally)

Use this procedure to mount the FlexPendant holder onto a flat surface, like the top of the controller or a desktop.

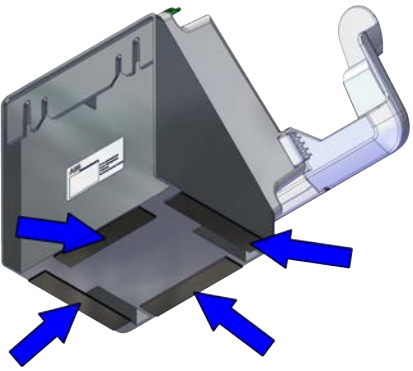
	Action	Note/illustration
1	Clean the surface and make sure it is dry.	
2	Remove the protective liner from the tape.	 <p>xx2000002352</p>

*Continues on next page*

### 3 Installation and commissioning

#### 3.4.3 Mounting the FlexPendant holder

*Continued*

	Action	Note/illustration
3	Press the holder onto the desired place.	 <p>xx2000002353</p>

#### Hanging the FlexPendant holder with the bracket

Use this procedure to hang the FlexPendant holder on any place that can hold the bracket, like the door of the equipment.



#### Tip

The bracket is included on delivery.

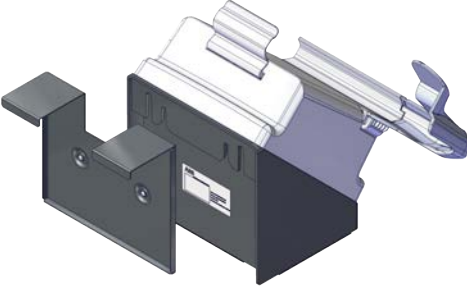
	Action	Note/illustration
1	Hang the FlexPendant holder to the bracket according to the screws on the bracket.	 <p>xx2000002354</p>
2	Hang the holder with the bracket to the desired place.	

*Continues on next page*

### 3 Installation and commissioning

#### 3.4.3 Mounting the FlexPendant holder

*Continued*

#### Hanging the front part of the FlexPendant holder with screws (Vertically)

Use this procedure to hang the front part of the FlexPendant holder to the desired place.

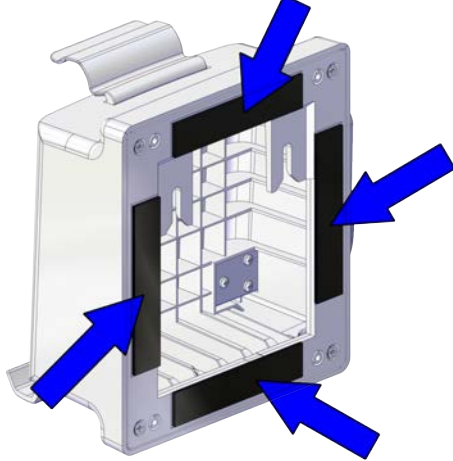
	Action	Note/illustration
1	Remove the four screws.	 xx2000002356
2	Separate the rear part from the FlexPendant holder.	
3	Clean the surface and make sure it is dry.	
4	Remove the protective liner from the tape.	 xx2000002357
5	Press the holder onto the desired place.	

*Continues on next page*

### 3 Installation and commissioning

#### 3.4.3 Mounting the FlexPendant holder

*Continued*

	Action	Note/illustration
6	Use two M5 screws to secure the holder.	 <p data-bbox="922 808 1034 831">xx2000002358</p>

#### 3.4.4 Connecting the Connected Services antenna

##### Connect the Connected Services antenna

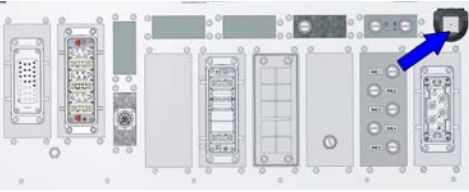
	Action	Note/Illustration
1	Place the magnet part of the antenna on the outside of the cabinet.	 <b>Note</b> The operating conditions must be such that there is a minimum separation distance of 20 cm between the dedicated antenna and nearby persons.
2	Insert the antenna cable through the cable grommet.	 xx2200001973
3	Apply cable ties and suitable cable protection to ensure that the cable may not be damaged by the door.	

*Continues on next page*

### 3 Installation and commissioning

#### 3.4.4 Connecting the Connected Services antenna

Continued

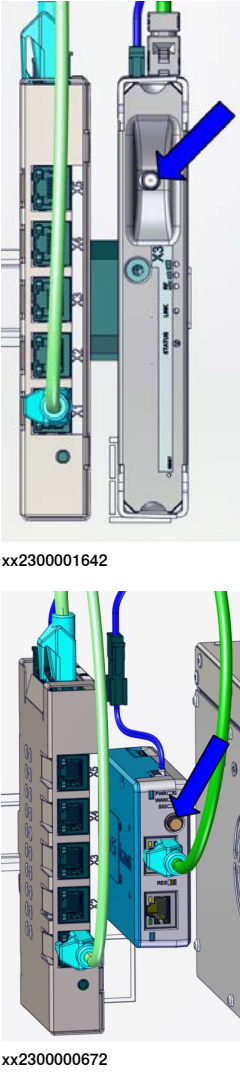
	Action	Note/Illustration
4	Connect the antenna cable to the Connected Services gateway by rotating the connector.	 <p>xx2300001642</p> <p>xx2300000672</p>



## 3.5 Electrical connections

### 3.5.1 Connectors on the OmniCore V250XT Type B controller

---

#### General

The following section describes the connectors on the OmniCore V250XT Type B controller.



#### **CAUTION**

Always inspect the connector for dirt or damage before connecting it to the controller. Clean or replace any damaged parts.

*Continues on next page*

### 3 Installation and commissioning

#### 3.5.1 Connectors on the OmniCore V250XT Type B controller

Continued

#### Connectors

The following details the connection interface on the OmniCore V250XT Type B controller.

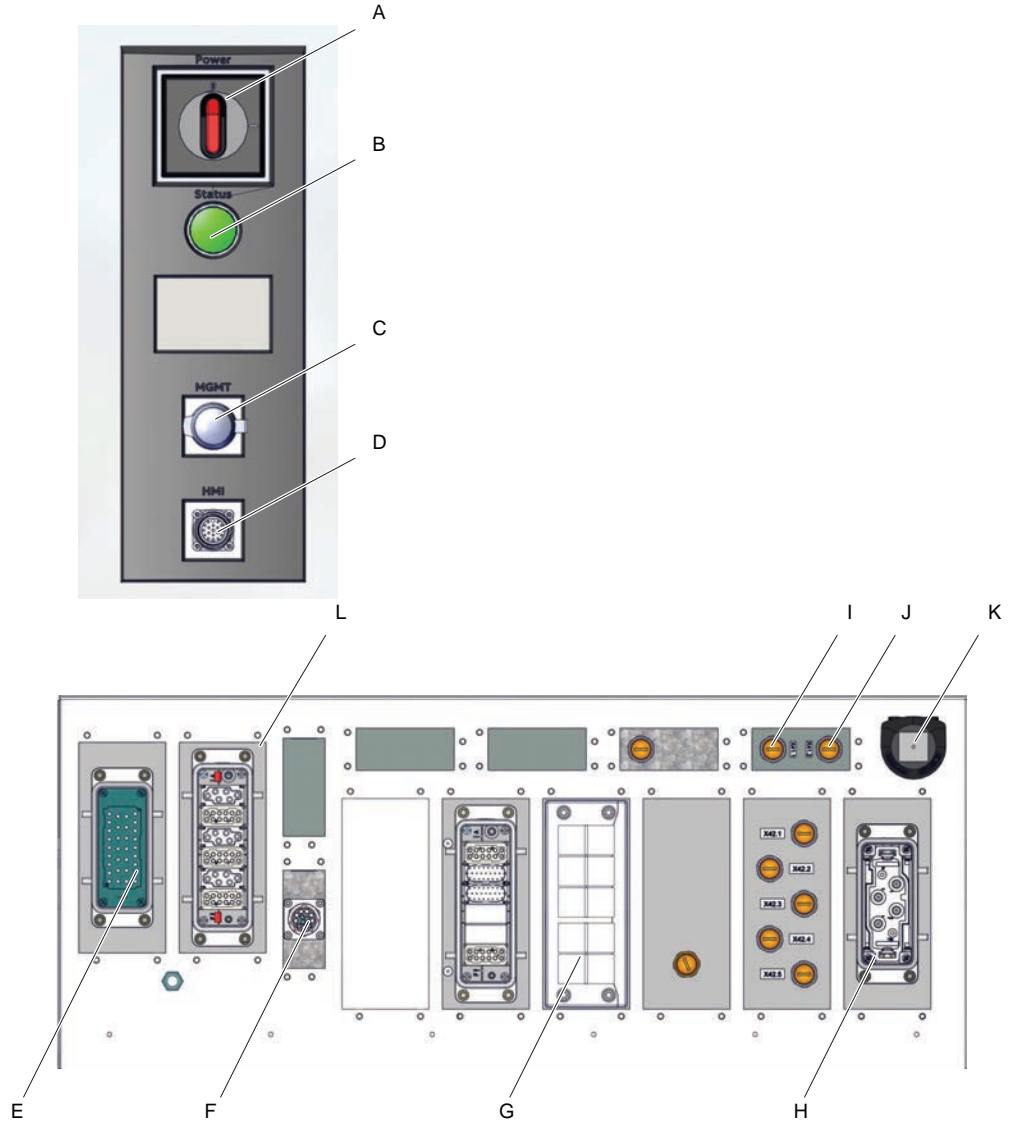

xx2200001457

	Description
A	Incoming mains switch
B	Motors on lamp
C	Ethernet outlet connector, MGMT (Management)
D	FlexPendant connector (HMI)
E	Motor connector
F	Manipulator signal connector (SMB)
G	Cable grommet assembly
H	Incoming mains connector
I	Ethernet outlet connector, LAN3

Continues on next page

### 3 Installation and commissioning

#### 3.5.1 Connectors on the OmniCore V250XT Type B controller

*Continued*

	Description
J	Ethernet outlet connector, WAN
K	Cable grommet for Connected Services antenna (3G/4G/WiFi)
L	ADU (additional drive unit) connector

## 3 Installation and commissioning

### 3.5.2 Connecting cables to the controller

#### 3.5.2 Connecting cables to the controller

##### General

A good and proper electrical installation of the robot system is necessary to ensure the best performance and prolong the lifetime of the whole robot system.

This section includes important information on how to connect cables and signals to the controller.

##### Signal classes

Different rules apply to the different classes when selecting and laying cables. Signals from different classes must not be mixed.

Signal class	Description
Power signals Class 4 (noisy)	Supplies external motors and brakes. Applies to the cables associated with the power inputs and outputs of variable speed drives. Cables carrying strongly interfering signals such as motor cables, DC-link load sharing, unsuppressed inductive loads, DC motors, welding equipment, etc.
Control signals Class 3 (slightly noisy)	Digital operating and data signals (digital I/O, protective stop, etc.). Applies to cables carrying slightly interfering signals: AC power supply (<1 kV), DC power (24 V), power to equipment with RFI/EMI filters, control circuits with resistive or suppressed inductive loads (such as contactors and solenoids), direct-on-line induction motors, etc.
Measurement signals Class 2 (slightly sensitive)	Analog measurement and control signals (resolver and analog I/O). This class covers ordinary analogue signals such as analogue signals (4-20 mA, 0-10V, or signals below 1 MHz), low-speed digital signals (RS232, RS485), digital (on/off) signals, limit switches, encoders, etc.
Data communication signals Class 1 (sensitive)	Gateway (fieldbus) connection, computer link. Applies to cables carrying very sensitive signals. Signals with a full-scale range less than 1 V or 1 mA, and/or a source impedance >1 kOhm, and/or a signal frequency >1 Mhz. For example high-speed digital communication (Ethernet), thermocouples, thermistors, strain gauges and flowmeters.

##### Selecting cables

All cables laid in the control cabinet must be capable of withstanding 70 °C. In addition, the following rules apply to the cables of certain signal classes:

Signal class	Cable type
Power signals	Shielded cable with an area of at least 0.75 mm <sup>2</sup> or AWG 18.
Control signals	Shielded cable.
Measurement signals	Shielded cable with twisted pair conductors.
Data communication signals	Shielded cable with twisted pair conductors. A specific cable should be used for field bus connections and Ethernet, according to the standard specification of the respective bus.

*Continues on next page*



**Note**

Any local standards and regulations concerning insulation and area must always be complied with.

**AC current in CP/CS**

For specific applications where the correct cable dimensioning can depend on the relationship between the period of the duty cycle and the thermal time constant of the cable (for example, starting against high-inertia load, intermittent duty), the cable manufacturer can provide information.

Country specific norms have to be included.

The wire is not dimensioned to take care of starting motors or transformers.

The following table shows how much AC current can be supplied with a specific temperature, and the wire size.

Wire size (mm <sup>2</sup> //AWG)	AC current			
	40°C//104F	45°C//113F	50°C//122F	52°C//125.6F
Single wire 0.2//24	4.5	4.1	3.7	3.2
Multi wire 2 pair 0.2//24	3.6	3.3	3.0	2.6
Multi wire 4 pair 0.2//24	2.9	2.7	2.4	2.1
Multi wire 6 pair 0.2//24	2.6	2.3	2.1	1.8
Multi wire 9 pair 0.2//24	2.3	2.0	1.8	1.6
Single wire 0.5//20	7.9	7.2	6.5	5.6
Multi wire 2 pair 0.5//20	6.3	5.8	5.2	4.5
Multi wire 4 pair 0.5//20	5.1	4.7	4.2	3.6
Multi wire 6 pair 0.5//20	4.5	4.1	3.7	3.2
Multi wire 9 pair 0.5//20	4.0	3.6	3.2	2.8
Single wire 0.75//18	9.5	8.6	7.8	6.7
Multi wire 2 pair 0.75//18	7.6	6.9	6.2	5.4
Multi wire 4 pair 0.75//18	6.2	5.6	5.1	4.4
Multi wire 6 pair 0.75//18	5.4	4.9	4.4	3.8
Multi wire 9 pair 0.75//18	4.8	4.3	3.9	3.4
Single wire 1.0//17	11.0	10.0	9.0	7.8
Multi wire 2 pair 1.0//17	8.8	8.0	7.2	6.2
Multi wire 4 pair 1.0//17	7.2	6.5	5.9	5.1
Multi wire 6 pair 1.0//17	6.3	5.7	5.1	4.5
Multi wire 9 pair 1.0//17	5.5	5.0	4.5	3.9
0.75//18 three phase	8.6	7.8	7.1	5.6
1.0//17 three phase	10.3	9.4	8.4	6.7

*Continues on next page*

## 3 Installation and commissioning

### 3.5.2 Connecting cables to the controller

*Continued*

#### Route the cables

Routing of cables shall be done in a professional way.

- Cables of different classes, such as signal cables and power cables, must not be routed together as the power cables may introduce noise in the signal cables. The greater the separation distance, the lesser the risk for interference between the cables.
- Robot controller mains supply input cable and robot power cable should be separated even though they belong to the same class.
- If crossing cables from different classes, cables should cross at an angle close to 90 degrees.
- All external cables that are to be connected inside the controller must be shielded in the chassis before entering the cabinet.

Separation distances can be reduced if e.g. dividers are used between cables classes. Manufacturers of cable duct systems can provide information on how reduced separation distances can be achieved using their specific products.

Signal class	Cable type
Power signals	<ul style="list-style-type: none"><li>• These signals generate a lot of interference and must be laid separate from control, measurement, and communication signals.</li><li>• The shielding must be connected to a paint-free part of the panel chassis of the cabinet at both ends of the cable. Any unshielded cable must be as short as possible.</li><li>• The manipulator power cables are routed on the floor and along the left side of the controller cabinet.</li><li>• Cables should not be wound up like coils. This could cause an magnetic field disturbing the signals. There will also be a risk of overheating depending on the load.</li></ul>
Control signals	<ul style="list-style-type: none"><li>• These signals are very sensitive to interference. To protect these signals they should not be laid along with the power signals.</li></ul>
Measurement signals	
Data communication signals	

#### Shielding cables

When peripheral devices are connected to the robot system, a shielded cable is necessary to reduce coupling of the inner cable conductors to the environment they pass through.

#### Shielding cable requirements

- The best method for shielding is to ground the shield at both ends of the cable, provided the ends grounding are at the same potential.
- If the grounding points have different electric potentials - grounding both ends will create a ground loop allowing unwanted current to flow in the shield. In such cases one end grounding may be used. The grounding point should then be at the robot controller side.
- Cables carrying analog low-level signals is another exception where the shield should be grounded at only one end.

*Continues on next page*

- Most data network and field bus types have defined grounding topologies. If such grounding schemes exist, they should be followed.
- In complex interference environments, two-layer shielding may be required. The inner shield should be grounded at the controller side only end and the outer shield should be grounded at both ends. The optimum shielding is a combination of foil and braid screens.
- The best connection is one in which the shielding is extended up to and makes a solid 360° connection (shown below) with the ground plane or chassis.

#### Shielding example

The below example shows the shielding of a d-type connector:

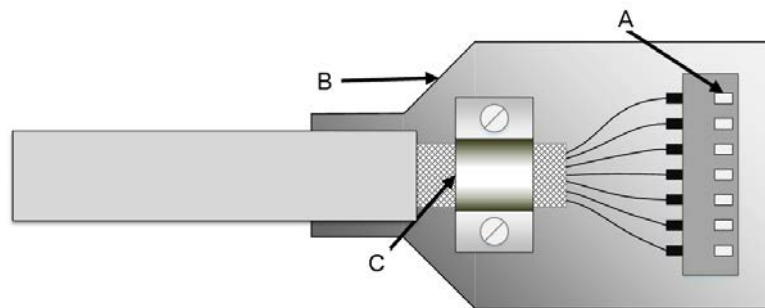

xx1700001320

- A A dimpled connector body makes multiple bonds to the mating connector body all around its periphery, 360° bonding.
- B Metal, or metallized, back shell makes 360° bond to the connector body.
- C The cable shield is exposed and 360° clamped to the back shell. A tight fit is a must.

Many other 360° bonding methods and types of 360° shielded connectors are also acceptable.

#### Shield pigtail termination

Shield pigtail termination, as shown below, shall be avoided. If a pigtail connection cannot be avoided, make it as short as possible.

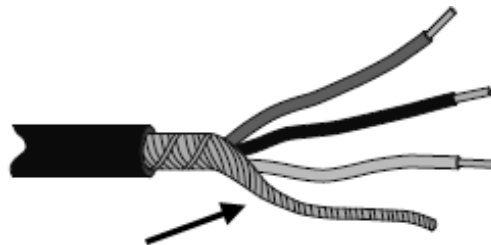

xx1700001321

*Continues on next page*

## 3 Installation and commissioning

---

### 3.5.2 Connecting cables to the controller

*Continued*

---

#### Ground and screen connections

The task of the grounding system is twofold - protective and functional. The primary task is to serve as protective earth (PE) for personal and equipment safety. The secondary task is to serve as a return path for common mode current.

For further information refer to EN 60204-1 and UL 1740.

#### Grounding requirements

The controller cabinet ground must come from the mains power supply PE.

- The grounding cable color shall be green-yellow.
- The ground for the controller cabinet, robot manipulator and peripheral devices must be the same, preferably an equipotential ground grid (mesh).
- Ground connection points must have stable inter-metallic bonding, like screw fixation. Paint, dirt, rust, and other insulating material must be removed from the contacting surfaces.

For requirements on the marking of the supply ground connection inside the control cabinet refer to UL 508C. For further details on how grounding systems should be designed refer to IEC 61000-5-2. For details of cross-sectional area of PE refer to IEC 60204-1.

#### Grounding installation

For information on how to connect protective earth to the OmniCore controller cabinet, see [Connecting incoming mains and protective earth to the controller on page 84](#).

For information on how to connect protective earth for the manipulator, see the corresponding product manual.

*Continues on next page*



#### Examples

The following figure shows 2 examples on how protective earth and the signal cable screens can be connected:

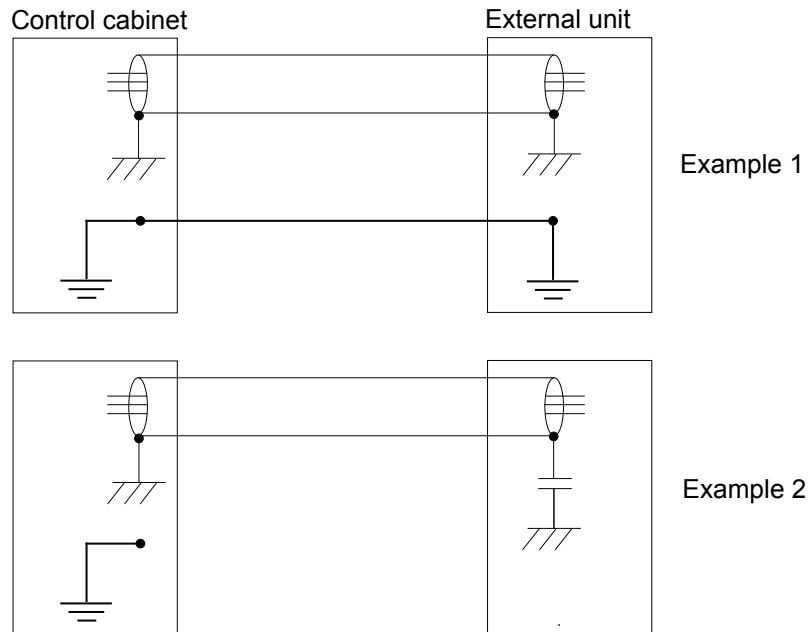

xx120000960

#### Example 1:

- Where a good earth connection is available on all units, the best shielding is obtained by grounding all screens at both ends on all units.

#### Example 2:

- If the cable is terminated where a good earth connection is not available a noise suppression capacitor can be used. The screens of the 2 cables must be connected as shown in the figure, but not connected to the chassis of the unit.

*Continues on next page*

### 3 Installation and commissioning

#### 3.5.2 Connecting cables to the controller

Continued

#### Interference elimination

Internal relay coils and other units that can generate interference inside the control cabinet are neutralized. External relay coils, solenoids and other units must be clamped in a similar way. The illustration below shows how this can be done.

Note that the turn-off time for DC relays increases after neutralization, especially if a diode is connected across the coil. Varistors give shorter turn-off times. Neutralizing the coils lengthens the life of the switches that control them.

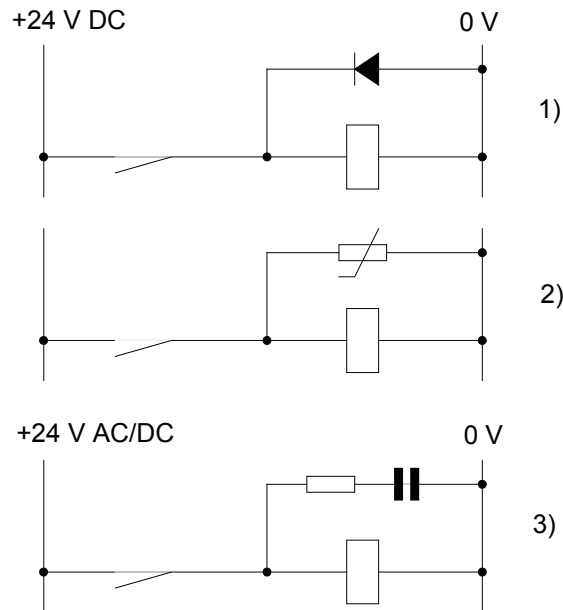

xx1200000961

- 1 The diode should be dimensioned for the same current as the relay coil, and a voltage of twice the supply voltage.
- 2 The varistor should be dimensioned for the same energy as the relay coil, and a voltage of twice the supply voltage.
- 3 When AC voltage is used, the components need to be dimensioned for >500 V max voltage and 125 V nominal voltage.

The resistor should be 100  $\Omega$ , and the capacitor should be 1W 0.1 - 1  $\mu\text{F}$  (typically 0.47  $\mu\text{F}$ ).

### 3.5.3 Power supply system requirements

#### Definition of the power supply system

IEC 60364 defines three different types of mains grounding using the two-letter codes. These are TN, TT, and IT.

First letter	Type of ground connection
T	Direct connection of one point to ground.
I	Not connected to ground or connected to ground via a high impedance.

Second letter	Connection between ground and the device being supplied
T	Direct connection of one point to ground.
N	Direct connection to neutral at the origin of installation, which is connected to the ground

In the following section the transformer configuration refers to the transformer secondary side. Configuration of the transformer primary side is not discussed in this context.

#### Allowed power supply systems

Only the following systems are allowed by ABB:

TN-S system	TN-C system
PE and N are separate conductors that are connected together only near the transformer.	A combined PEN conductor is used as both a PE and an N conductor.
<p>xx1700001310</p>	<p>xx1700001311</p>



#### Note

The networks must be symmetrical with respect to protective earth.

#### Isolation transformer

A three-phase isolation transformer between the mains supply and the control cabinet is required for any of the below conditions:

- If the available grid do not comply with the above described allowed power systems, as mentioned in [Allowed power supply systems on page 79](#).
- When the mains supply is shared with a pressing machine, frequency converter, or other large industry equipment that may cause the power supply

*Continues on next page*

### 3 Installation and commissioning

#### 3.5.3 Power supply system requirements

Continued

characteristics out of standard limits. To some extent, isolation transformers will filter out harmonics, spikes and surges.

For further information refer to regional power supply standards.

#### Allowed isolation transformer types

The following isolation transformer types are allowed by ABB:

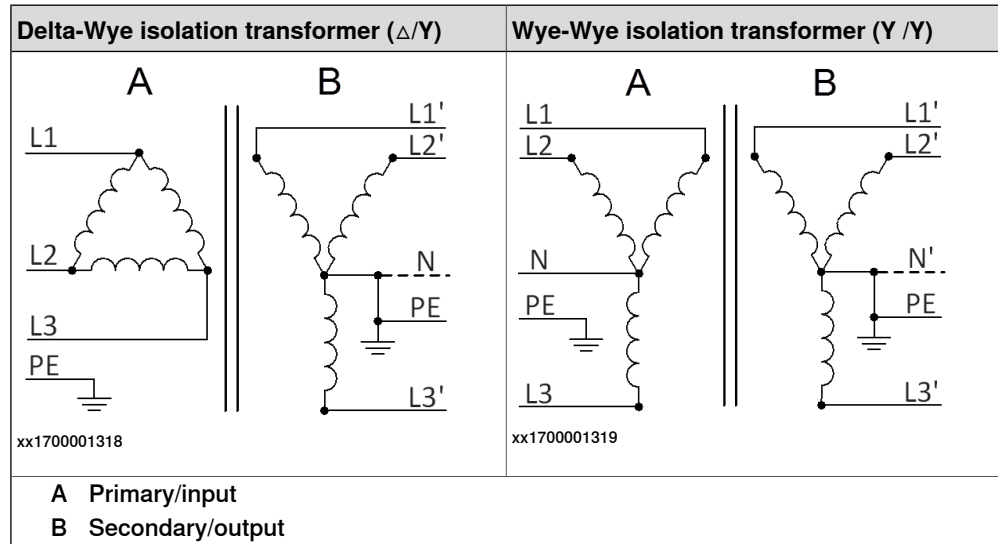

#### 3.5.4 Connecting the manipulator to the controller

##### General

Connect the manipulator and the controller to each other after installing them. The lists below specify which cables to be used in each application.

All connectors on the controller are shown in section [Connectors on the OmniCore V250XT Type B controller on page 69](#).



##### CAUTION

Verify that the serial number is according to the number(s) in the *Declaration of Incorporation (DoI)*.

##### Main cable categories

All cables between the manipulator and the controller are divided into the following categories:

Cable category	Description
Manipulator cable	Handles power supply to and control of the manipulator's motors as well as feedback from the serial measurement board.
Position switch cables (option)	Handles supply to and feedback from any position switches.
Customer cables (option)	Handles communication with equipment fitted on the manipulator by the customer.
Additional axes cables (option)	Handles power supply to and control of the external axes motors as well as feedback from the servo system.

These categories above are divided into sub-categories which are specified in spare part manual. See [Manipulator cables on page 470](#).

##### Connecting the cables from the manipulator to the controller

	Action
1	Connect the manipulator cable to the connector X1.
2	Lock the connector with the lever.
3	Secure the cables to avoid tripping or wear.

### 3 Installation and commissioning

#### 3.5.5 Fitting the connector for incoming mains

#### 3.5.5 Fitting the connector for incoming mains

##### General

This section describes how to manufacture a cable for connecting the main power to the controller.

##### Detailed view

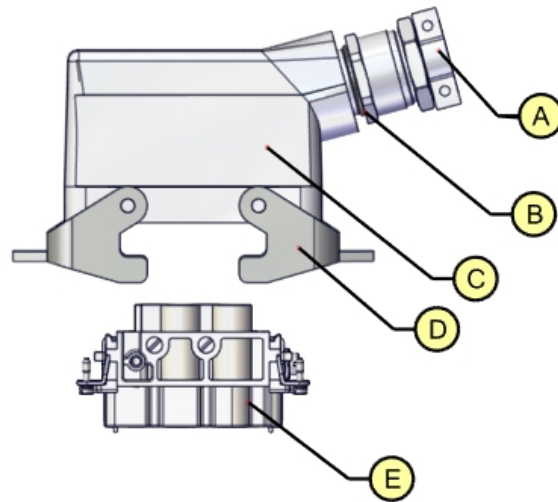

xx2100001257

	Description
A	Cable gland
B	O-ring
C	Hood, EMC
D	Locking lever (x2)
E	Connector insert

##### Specifications

The following describes the cable requirements for the incoming mains connection to the OmniCore V250XT Type B controller.

Component	Description
Cable type	Flexible oil resistant rubber
Cable area	3G x 6 mm <sup>2</sup> or AWG10
Protective earth	PE1 and PE2 points on X0 (incoming mains connector).

##### Included parts

The following parts are included in the delivery.

Part	Order number	Quantity
Connector kit	3HAC075871-001	1

*Continues on next page*

### 3 Installation and commissioning

#### 3.5.5 Fitting the connector for incoming mains

*Continued*

#### Procedure

Use the following procedure to fit the connectors.

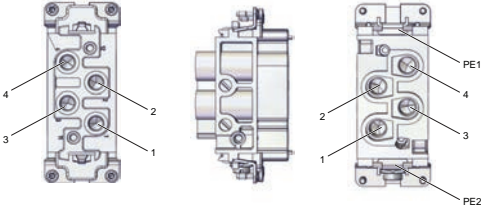
	Action	Note/illustration														
1	Cut the cable to desired length.															
2	Connect the wires according to the illustration.	 <p data-bbox="954 674 1062 689">xx2100001258</p> <table border="1" data-bbox="954 703 1437 1025"> <thead> <tr> <th data-bbox="954 703 1145 748"></th> <th data-bbox="1145 703 1437 748">Description</th> </tr> </thead> <tbody> <tr> <td data-bbox="954 748 1145 792">1</td> <td data-bbox="1145 748 1437 792">L1</td> </tr> <tr> <td data-bbox="954 792 1145 837">2</td> <td data-bbox="1145 792 1437 837">L2</td> </tr> <tr> <td data-bbox="954 837 1145 882">3</td> <td data-bbox="1145 837 1437 882">L3</td> </tr> <tr> <td data-bbox="954 882 1145 927">4</td> <td data-bbox="1145 882 1437 927">Not used</td> </tr> <tr> <td data-bbox="954 927 1145 972">PE1</td> <td data-bbox="1145 927 1437 972">Protective earth</td> </tr> <tr> <td data-bbox="954 972 1145 1016">PE2</td> <td data-bbox="1145 972 1437 1016">Protective earth</td> </tr> </tbody> </table>		Description	1	L1	2	L2	3	L3	4	Not used	PE1	Protective earth	PE2	Protective earth
	Description															
1	L1															
2	L2															
3	L3															
4	Not used															
PE1	Protective earth															
PE2	Protective earth															
3	Tighten the screws to secure the cables.															
4	Remove screw and washer on top of contact and insert the ground cable with cable lug. Secure with washer and screws.															

## 3 Installation and commissioning

---

### 3.5.6 Connecting incoming mains and protective earth to the controller

### 3.5.6 Connecting incoming mains and protective earth to the controller

---

#### Introduction



#### Note

How to manufacture a cable with connector is described in section [Fitting the connector for incoming mains on page 82](#).



#### DANGER

A residual current device (RCD) must be installed. See [Residual current on page 42](#).



#### Note

The controller must be installed towards a 3-phase grounded Wye electrical configurations. The use of three phase power with delta connection voids warranty.



#### Note

For UL installations, the integral solid state short circuit protection does not provide branch circuit protection. Branch circuit protection must be provided in accordance with the Manufacturer Instructions, National Electrical Code and any additional local codes.

#### Prerequisites

Before incoming mains is connected to the controller, the following prerequisites must be fulfilled:

- An external circuit breaker or fuse must be installed. See [Line fusing on page 86](#).
- The cabinet must be connected to protective earth. See [Connection of protective earth on page 85](#).
- A residual current device (RCD) must be installed. See [Residual current on page 42](#).

*Continues on next page*



### 3 Installation and commissioning

#### 3.5.6 Connecting incoming mains and protective earth to the controller

*Continued*

##### Location of incoming mains connection

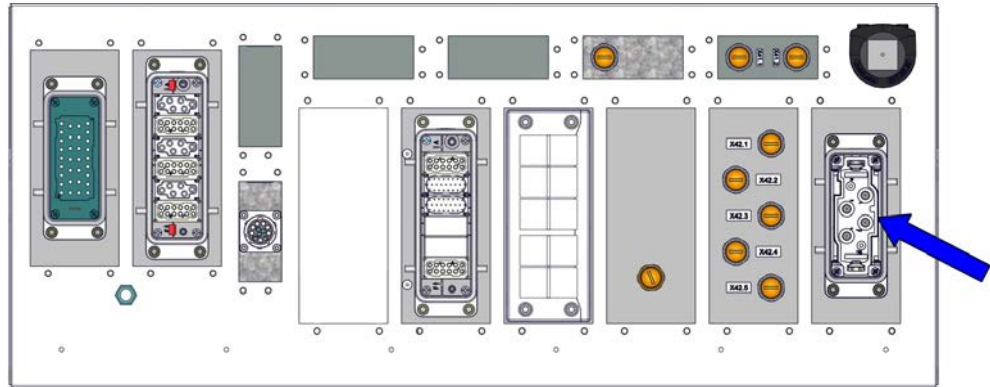

xx2200001755

##### Connection of protective earth

There are two options to connect the cabinet to protective earth:

- PE0 on front panel.
- PE1 and PE2 on X0 (incoming mains connector).

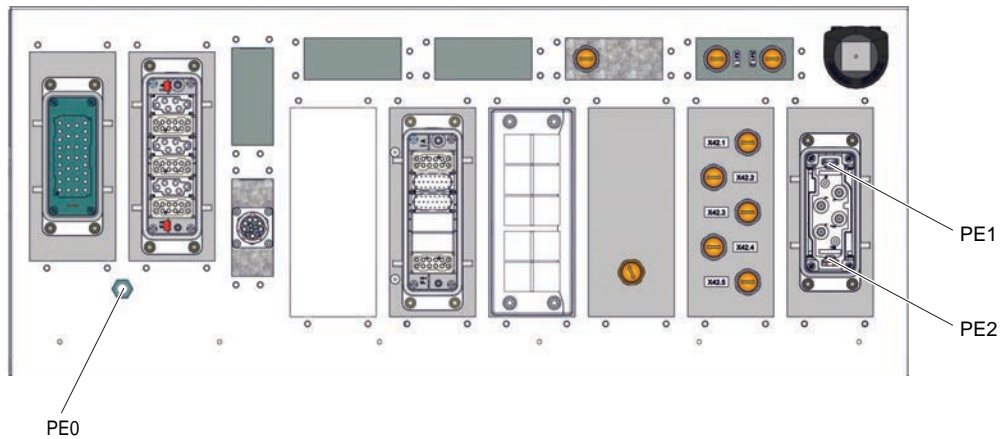

xx2200001756



##### Note

All connections between the cabinet and protective earth must comply with the local electrical requirements.

##### Required equipment

Equipment	Note
Main connection cable (three-phase)	L1, L2, L3, PE1, PE2 Details see <a href="#">Fitting the connector for incoming mains on page 82</a> .

*Continues on next page*

### 3 Installation and commissioning

#### 3.5.6 Connecting incoming mains and protective earth to the controller

Continued

Equipment	Note
External earth fault protection (residual current circuit breaker, Class B for frequency converters, 300mA)	For control cables up to 15m and mains supply voltage up to 400 VAC, a 30 mA earth fault protection can be used if it is Hager CDH440R, CDH440D or ABB F204 B-40/0,03.
External fuse or circuit breaker	32 A, Class K.  <b>Note</b> For installations according to UL requirements, use Circuit Breaker, Type SU203M-K32, manufactured by ABB.
Standard toolkit	See <a href="#">Standard toolkit for controller on page 436</a> .
Circuit diagram	<i>Circuit diagram - OmniCore V250XT, rev 04 or later, 3HAC074000-008</i>

#### Connecting the power

The following procedure describes how to connect the main power to the controller.



#### CAUTION

Always inspect the connector for dirt or damage before connecting it to the controller. Clean or replace any damaged parts.

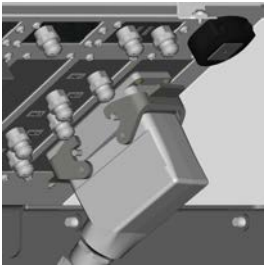
	Action	
1	<p>Connect the main power cable to the incoming mains connector X0 and lock it by pressing the locking levers.</p>  <b>Tip</b> When you hear a clear clicking sound, it is locked.	 xx2100001259

#### Line fusing

An external circuit breaker (class K) or fuse must be added to prevent short circuit and overload. The full load current for the robot is marked on the controller name plate, and is also displayed in section [Line fusing on page 41](#).

### 3.5.7 Detaching and attaching a FlexPendant

#### Introduction

With the option *Hot swappable FlexPendant [3018-1]* it is possible to detach and attach the FlexPendant from an OmniCore controller in automatic mode, without interrupting the ongoing process.

Detaching the FlexPendant in manual mode will always result in an emergency stop.



#### Note

Detaching the FlexPendant is possible only if the logged in user has the **Detach the FlexPendant** grant.



#### CAUTION

Before detaching the FlexPendant, another emergency stop shall be available.



#### CAUTION

With a detached FlexPendant, there is no visual identification of the operating mode.



#### CAUTION

A FlexPendant that is not connected to the robot must be stored out of sight so that it cannot be mistaken for being in use.



#### CAUTION

The FlexPendant connector shall only be used to connect the FlexPendant.

*Continues on next page*

### 3 Installation and commissioning

---

#### 3.5.7 Detaching and attaching a FlexPendant

*Continued*

---

#### Location of FlexPendant connector

The FlexPendant connector is located on the cabinet door.



xx210000829

---

#### Detaching the FlexPendant in automatic mode

Use the following procedure to detach the FlexPendant in automatic mode:

- 1 On the status bar, tap the **QuickSet** button.
- 2 Tap the **Logout/Restart** tab.
- 3 In the **FlexPendant** section, tap **Detach FlexPendant**.

*Continues on next page*

The Detach FlexPendant window is displayed.

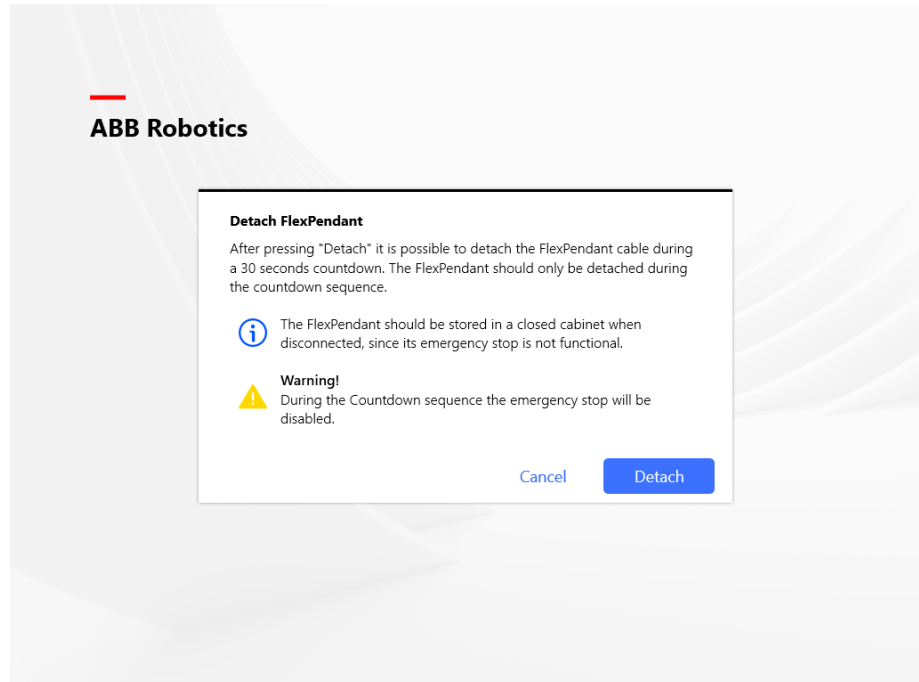

xx1900000403

#### 4 Tap Detach.

A popup window with 30 seconds countdown timer is displayed.

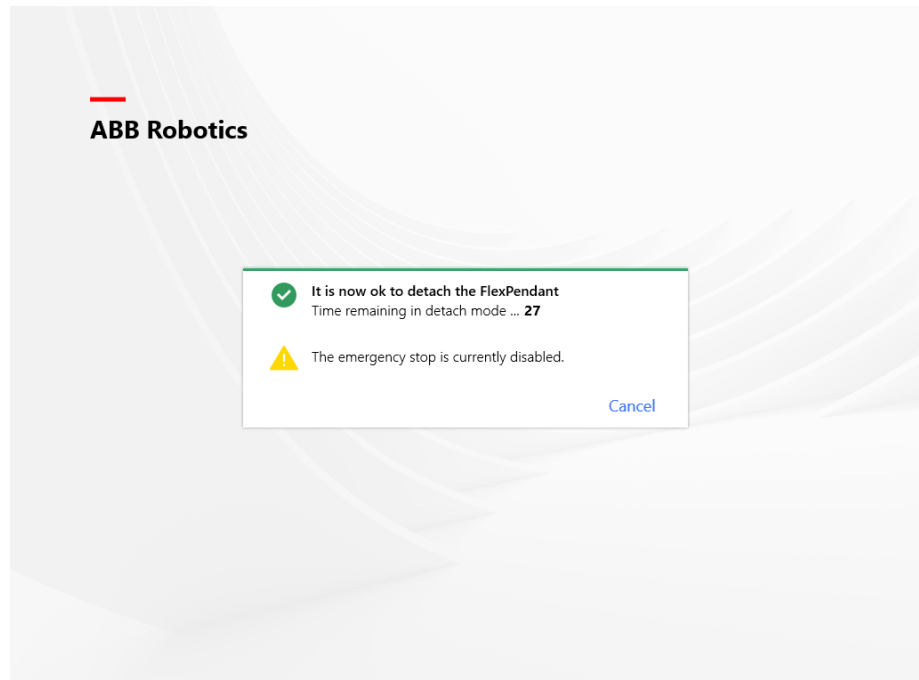

xx1900000404

#### 5 When the countdown is progressing, detach the FlexPendant.

*Continues on next page*

## 3 Installation and commissioning

### 3.5.7 Detaching and attaching a FlexPendant

*Continued*

When detached, the FlexPendant will shut down.



#### Note

If the FlexPendant is not detached within 30 seconds, the process for detach of the FlexPendant is aborted.



#### WARNING

If the FlexPendant is detached after the 30 seconds countdown has passed, the controller will enter emergency stop state.

### Attaching the FlexPendant



#### CAUTION

Always inspect the connector for dirt or damage before attaching. Clean or replace any damaged parts.

Attach the connector to the controller and tighten the locking ring or screws.

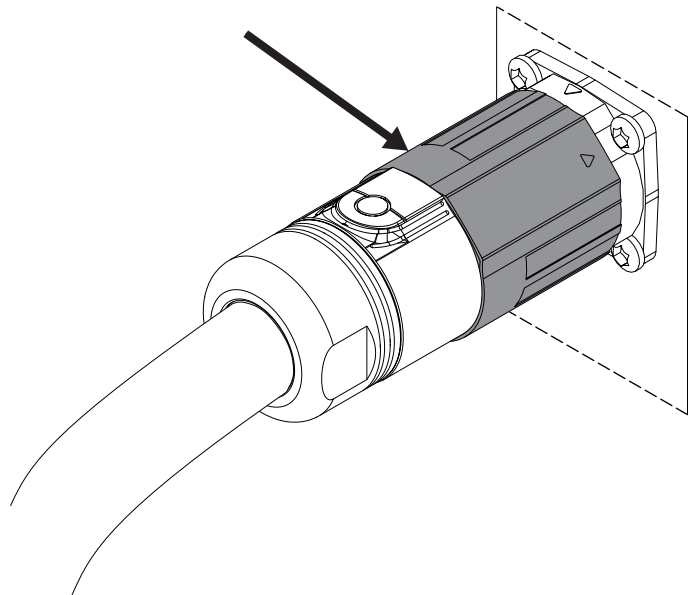

xx1900000975



#### CAUTION

Make sure that the emergency stop device is not pressed in before attaching the FlexPendant.

### 3.5.8 Ethernet networks on OmniCore

#### Network segment overview

The Ethernet networks used by OmniCore are distributed into the following segments:

Network segment	Controller ports	Usage
Private Network	DEV	Process equipment local to this specific robot.
	MGMT (Management)	<p>ABB service personnel in close proximity to the controller, with a single client connected to the controller.</p> <p> <b>Note</b></p> <p>The management port shall never be used for more than one client at a time. ABB Robotics assumes no responsibility for any errors/hazards that may appear when more than one client is used.</p>
	TPU	FlexPendant connection.
ABB Connect Network	ABB Connect	ABB Connect connection.
Public Network	WAN 1	Public/factory network.
	WAN 2	Intended for connecting the robot controller to a factory wide industrial network.
I/O Network	LAN	Intended for connecting the robot controller to a factory wide industrial network isolated from WAN.

### 3 Installation and commissioning

#### 3.5.9 Descriptions for connectors

#### 3.5.9 Descriptions for connectors

##### Power distribution board front panel connectors

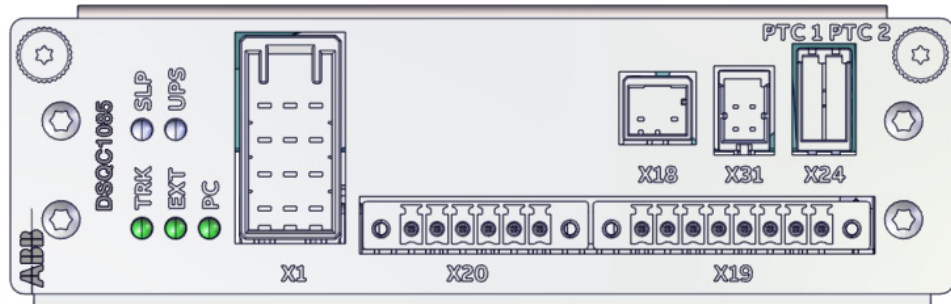

xx2300000434

##### Connector X1

	Description
Connection	Connector for 24V_TRUNK input
Type	Dynamic D-3400F Tyco Electronics
Article number	178216-2

Pin	Name	Description
A1	0V	
A2	0V	
A3	0V	
B1	0V	
B2	0V	
B3	0V	
C1	24V_TRUNK	
C2	24V_TRUNK	
C3	24V_TRUNK	
D1	24V_TRUNK	
D2	24V_TRUNK	
D3	24V_TRUNK	

##### Connector X19

	Description
Connection	Connector for 24V_IO_EXT output
Type	SC 3.81 90F Weidmüller
Article number	1793380000

*Continues on next page*



### 3 Installation and commissioning

#### 3.5.9 Descriptions for connectors

*Continued*

Pin	Name	Description
1	24V_IO_EXT	
2	0V_IO_EXT	
3	24V_IO_EXT	
4	0V_IO_EXT	
5	24V_IO_EXT	
6	0V_IO_EXT	
7	24V_IO_EXT	
8	0V_IO_EXT	

#### Connector X20

	Description
Connection	Connector for 24V_EXT input
Type	SC 3.81 90F Weidmüller
Article number	1793370000

Pin	Name	Description
1	24V_EXT	
2	24V_EXT	
3	24V_EXT	
4	0V_EXT	
5	0V_EXT	
6	0V_EXT	

#### Connector X18

	Description
Connection	Connector for MS_ON/OFF 24V digital output
Type	Dynamic D-2100S Tyco Electronics
Article number	1376135-3

Pin	Name	Description
1	MS_ONOFF	
3	0V	

#### Connector X31

	Description
Connection	Connector for system power mode control
Type	Dynamic D-1200D Tyco Electronics
Article number	2-1827876-2

*Continues on next page*

### 3 Installation and commissioning

#### 3.5.9 Descriptions for connectors

Continued

Pin	Name	Description
A1	24V_STDBY	24V standby power input
A2	0V	
B1	PWR_ON_BTN	Optional Power on button input
B2	PWR_EN	Digital 24V output

#### Connector X24

	Description
Connection	Connector for PTC inputs
Type	Dynamic D-1500T Tyco Electronics
Article number	1-1827583-2

Pin	Name	Description
A1	0V_CHASSI	
A2	0V_CHASSI	
B1	PTC1-	
B2	PTC2-	
C1	PTC1+	
C2	PTC2+	

#### Processor board front panel connectors



xx2300000440

#### Connector X1, X2, X3, X4, X6, X9

	Description												
Connection	Connectors for ECAT, MGMT, DEV, TPU and DRV (Motion Link)												
Type	RJ45												
Article number													
Label	<table border="1"> <tbody> <tr> <td>X1</td> <td>ECAT1, IN</td> </tr> <tr> <td>X2</td> <td>ECAT2, OUT</td> </tr> <tr> <td>X3</td> <td>MGMT</td> </tr> <tr> <td>X4</td> <td>DEV</td> </tr> <tr> <td>X6</td> <td>TPU</td> </tr> <tr> <td>X9</td> <td>DRV</td> </tr> </tbody> </table>	X1	ECAT1, IN	X2	ECAT2, OUT	X3	MGMT	X4	DEV	X6	TPU	X9	DRV
X1	ECAT1, IN												
X2	ECAT2, OUT												
X3	MGMT												
X4	DEV												
X6	TPU												
X9	DRV												

Continues on next page

Pin	Name	Description
1	BI_DA+	
2	BI_DA-	
3	BI_DB+	
4	N.A	
5	N.A	
6	BI_DB-	
7	N.A	
8	N.A	

#### Ethernet switch front panel connectors

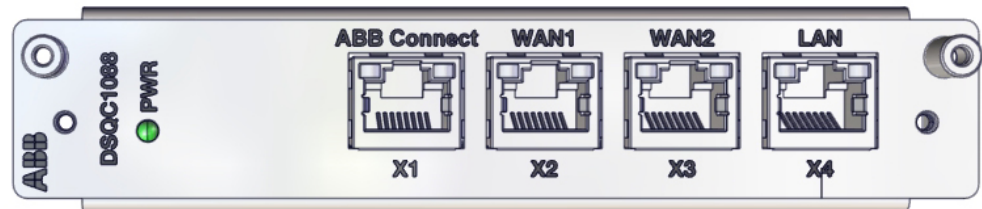

xx2300001768

#### Connector X1, X2, X3, X4

Description									
Connection	Connectors for ABB Connect, WAN1, WAN2 and LAN.								
Type	RJ45								
Article number									
Label	<table border="1"> <tbody> <tr> <td>X1</td> <td>ABB Connect</td> </tr> <tr> <td>X2</td> <td>WAN1</td> </tr> <tr> <td>X3</td> <td>WAN2</td> </tr> <tr> <td>X4</td> <td>LAN</td> </tr> </tbody> </table>	X1	ABB Connect	X2	WAN1	X3	WAN2	X4	LAN
X1	ABB Connect								
X2	WAN1								
X3	WAN2								
X4	LAN								

Pin	Name	Description
1	BI_DA+	
2	BI_DA-	
3	BI_DB+	
4	BI_DC+	
5	BI_DC-	
6	BI_DB-	
7	BI_DD+	
8	BI_DD-	

*Continues on next page*

### 3 Installation and commissioning

#### 3.5.9 Descriptions for connectors

Continued

#### Safety board front panel connectors



xx2300000501



#### CAUTION

Safety functions must be verified before use. Safety functions must be tested regularly.

#### Connector X13

	Description
Connection	Connector for HMI signals
Type	Dynamic D-2100D Tyco Electronics
Article number	1376137-1

Pin	Name	Pin	Name
A1	24V_CH1_HMI	B1	ENABLE_CH1
A2	HMI_ESTOP_CH1	B2	0V_IO_HMI
A3	HMI_ESTOP_CH2	B3	ENABLE_CH2
A4	0V_IO_HMI	B4	24V_CH2_HMI
A5	24V_TPU	B5	0V_TPU
A6	MON_LAMP	B6	24V_MON
A7	MON_PB	B7	24V_MON
A8	-	B8	-
A9	-	B9	-
A10	-	B10	-

#### Connector X14

	Description
Connection	Connector for Safety IO signals
Type	S2L 3.50 90F Weidmüller
Article number	1728680000

The connector X14 allows for connecting *general stop* and *emergency stop* devices. *General Stop* is operational in both manual mode and automatic mode. See [Protective stop and emergency stop on page 21](#).

Continues on next page

More information is also available in *Application manual - Functional safety and SafeMove*.

External emergency stop devices can for example be required in the following cases:

- FlexPendant is detached.
- FlexPendant is placed in its holder with the emergency stop device hidden behind the emergency stop device cover.

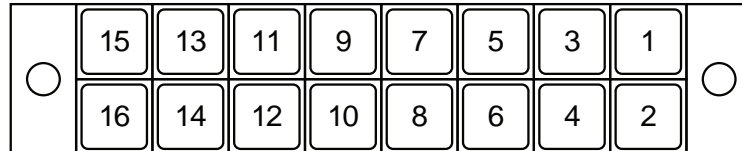

xx1800000553

Pin	Name	Pin	Name
1	0V_IO_EXT	2	24V_CH2_EXT
3	EXT_ESTOP_CH2_N	4	EXT_ESTOP_CH2_P
5	EXT_ESTOP_CH1_N	6	EXT_ESTOP_CH1_P
7	0V_IO_EXT	8	24V_CH1_EXT
9	0V_IO_EXT	10	24V_CH2_EXT
11	GS_CH2_N	12	GS_CH2_P
13	GS_CH1_N	14	GS_CH1_P
15	0V_IO_EXT	16	24V_CH1_EXT



#### Note

The following operating regions are defined according to IEC 61131-2:2017 clause 6.4.4.2:

- The emergency stop function is activated (open loop) when the voltage is below 5 V.  
The protective stop function is activated (open loop) when the voltage is below 5 V.
- The transition region is between 5 V and 15 V.
- The emergency stop function is not activated (closed loop) when the voltage is above 15 V.  
The protective stop function is not activated (closed loop) when the voltage is above 15 V.

*Continues on next page*

### 3 Installation and commissioning

#### 3.5.9 Descriptions for connectors

Continued

A protective stop device needs to be connected to the protective stop input. See example below.

Customer provided protective stop device

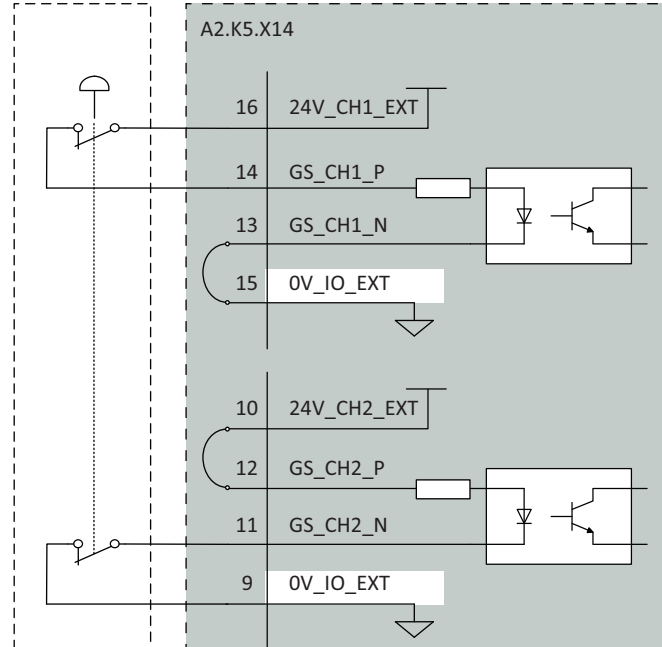

xx2300000995

The protective stop input can be powered from an external power supply:

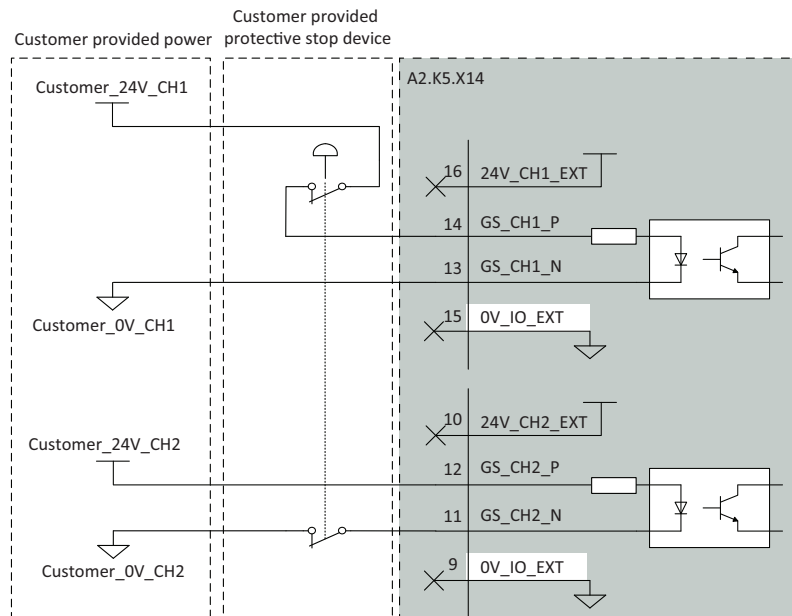

xx2300000996

Continues on next page

The emergency stop input needs to be connected to an emergency stop device. This to allow operation in both automatic and manual mode:

Customer provided emergency stop device

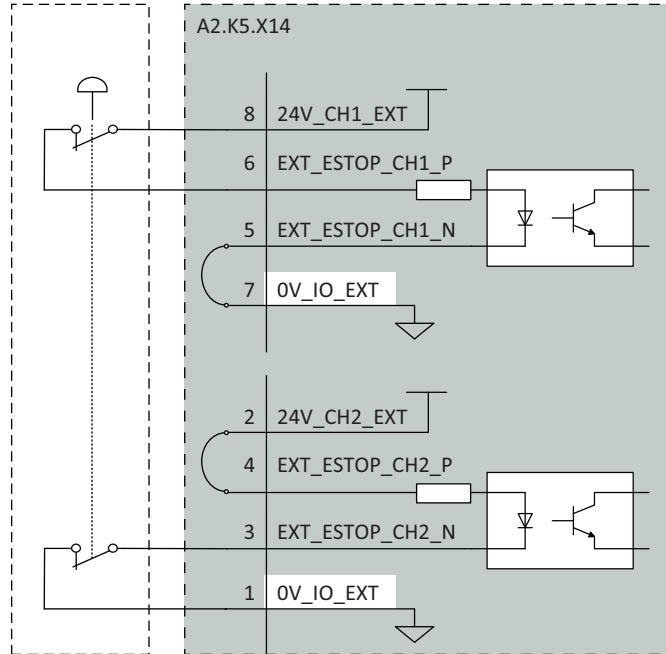

xx230000997

The emergency stop input can be powered from an external power supply:

Customer provided power emergency stop device

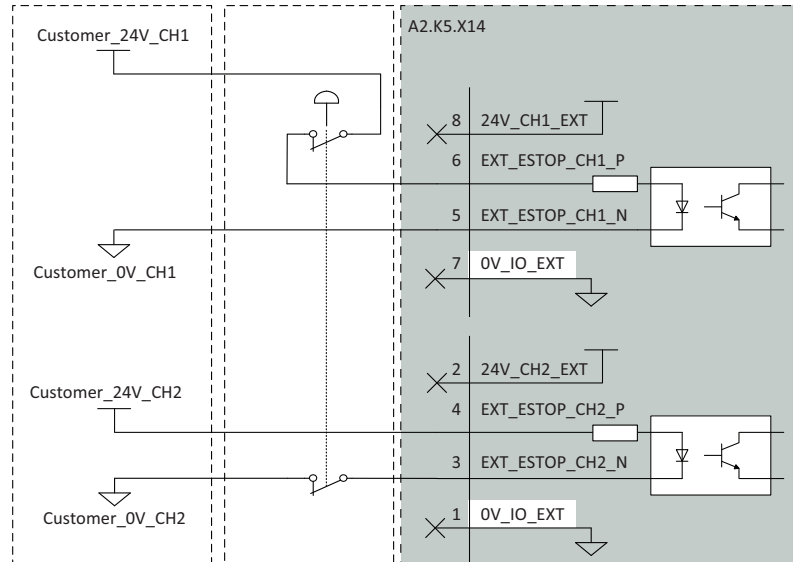

xx230000998

*Continues on next page*

### 3 Installation and commissioning

#### 3.5.9 Descriptions for connectors

Continued

The digital inputs comply with the requirements of current sinking inputs type 1 for rated voltage 24 VDC according to IEC 61131-2:2017 clause 6.4.4.2.



#### Note

If external power supplies are used, they must have over-current protection. A recommendation is to have separate fuses (0.5A) for each channel (Ch1, Ch2) to increase diagnostic coverage on inputs.



#### Note

If separate power supplies are used for each channel (Ch1, Ch2) they must have common ground.

For more connections other than those illustrated above, carefully assess the risk before use and contact your local ABB for support.

#### Connector X15

	Description
Connection	Connector for Safety IO signals
Type	S2L 3.50 90F Weidmüller
Article number	1728690000

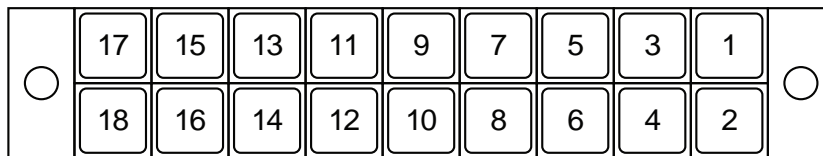

xx180000555

Pin	Name	Pin	Name
1	MON_PB1	2	24V_MON
3	MON_LAMP1	4	24V_MON
5	-	6	-
7	0V_IO_EXT	8	24V_CH2_EXT
9	AS_CH2_N	10	AS_CH2_P
11	ESOUT2_N	12	ESOUT2_P
13	ESOUT1_N	14	ESOUT1_P
15	AS_CH1_N	16	AS_CH1_P
17	0V_IO_EXT	18	24V_CH1_EXT

The connector X15 allows for connecting *automatic stop* devices.

*Automatic Stop* is only operational in automatic mode. See [Protective stop and emergency stop on page 21](#).

More information is also available in *Application manual - Functional safety and SafeMove*.

Continues on next page



A protective stop device needs to be connected to the protective stop input. See example below.

Customer provided protective stop device

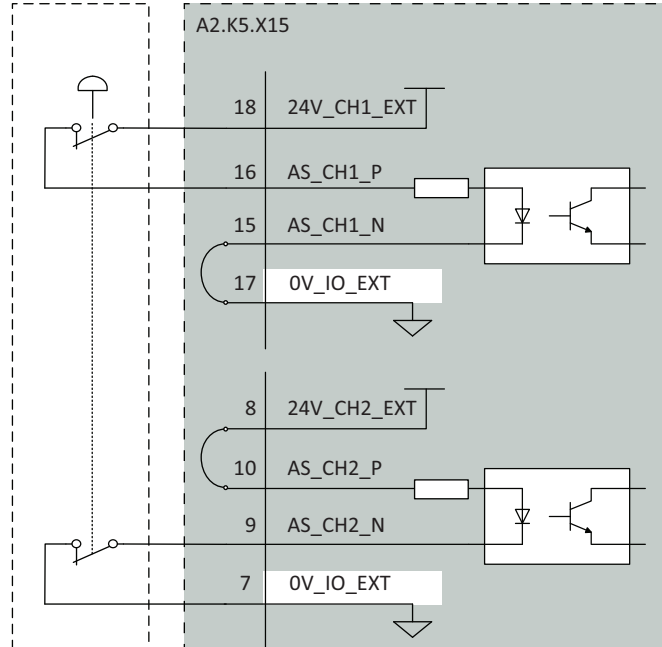

xx230000993

The protective stop input can be powered from an external power supply:

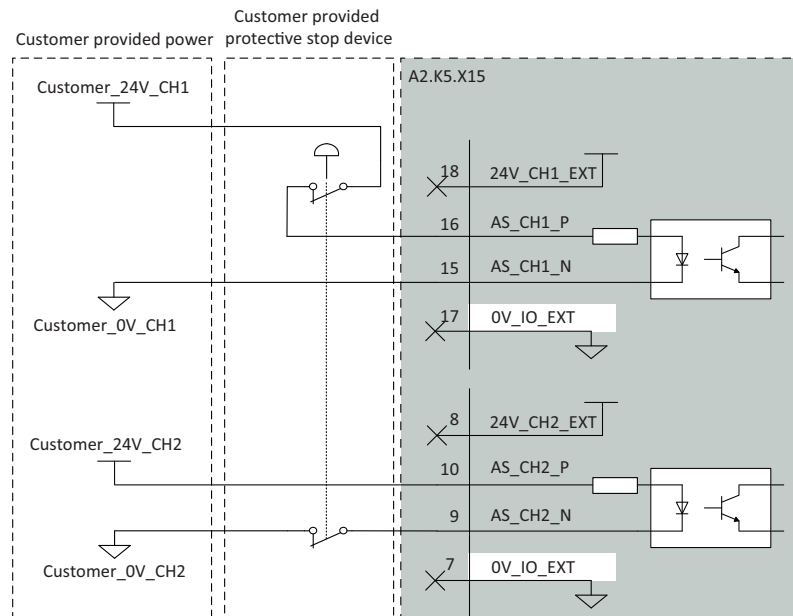

xx230000994

*Continues on next page*

### 3 Installation and commissioning

#### 3.5.9 Descriptions for connectors

Continued



#### Note

The relay channels are able to switch 2A rated current at 24 VDC rated voltage according to IEC 61131-2:2017 clause 6.4.6.1, 24VDC outputs, Type 2, non-protected output.

Over-current protection must be provided by customer.

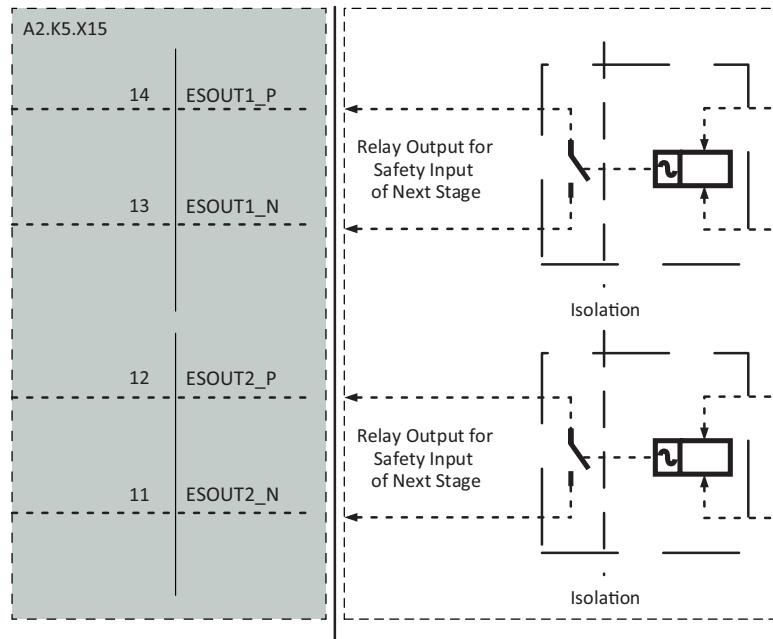

xx230000999



#### Note

State 0 of Emergency stop output shall be recognized as Emergency stop triggered.



#### Note

The cable shall be protected from external EM disturbance, suggested to use separate multicore cables.



#### Note

The ESOUT pins reflect the emergency status of the controller.  
ESOUT can be decoupled from ES input to avoid dead-lock in an emergency stop chain. See [Configuring robot stopping functions on page 108](#).



#### Note

To increase diagnostic cover on Emergency Stop output suitable diagnostics measures on the relay interfacing device could be added, such as antivalence or pulse testing by external interfacing safety device.

Continues on next page

Although the Motors On function is available on the FlexPendant, an interface is provided in X15 for an optional Motors On push button and an indication lamp.

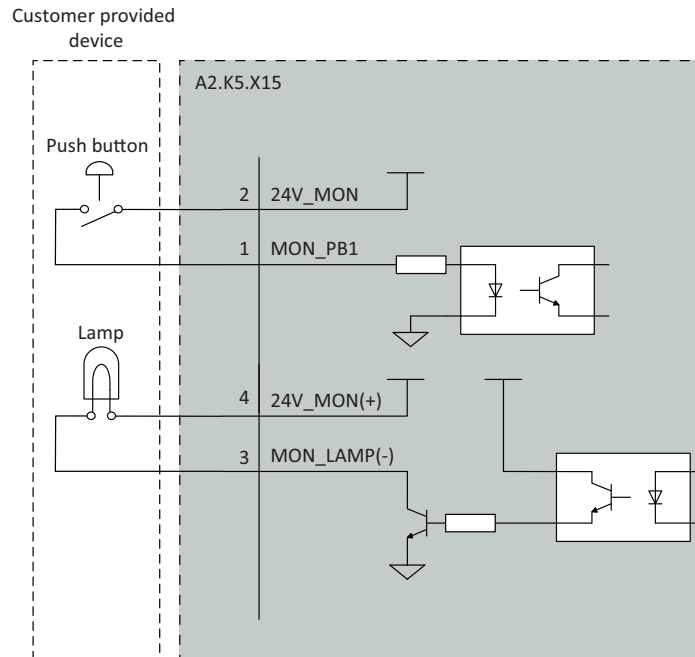

xx2300001000

#### Antenna connector

The Connected Services Gateway unit has either an ABB Connect port or an antenna connector on the front. See installation procedures in section [On-site installation on page 58](#).



xx1900002450

*Continues on next page*

### 3 Installation and commissioning

#### 3.5.9 Descriptions for connectors

*Continued*

The Connected Services Gateway unit has an antenna connector on the front. See installation procedures in section [On-site installation on page 58](#).

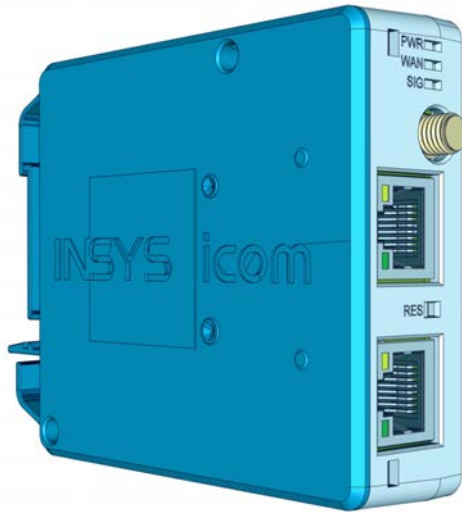

xx230000668

#### Customer cable layout

The antenna should go through the cable grommet and fasten on the cabinet.



#### Note

The end user needs to install proper grommets according to the diameter of the cables which need to go through the grommet.

Incorrect use of grommets will affect ingress protection, EMI/EMC and temperature.

It is recommended to use icotek KT grommet.

#### Ethernet outlet connector, MGMT (Management)

The following type of Ethernet cable is recommended for connection to the Ethernet outlet connector (MGMT port):

Ethernet cable	Value
Maximum length	75 m
Type of cable	CAT5e SF/UTP

*Continues on next page*

#### I/O connectors - Scalable I/O (option)

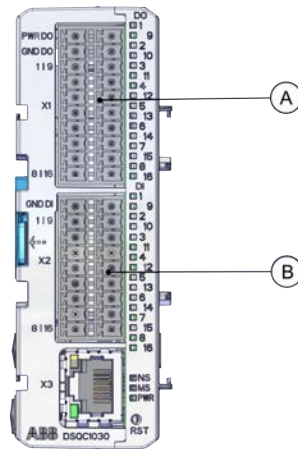

xx1900002448

A	Scalable I/O output connectors
B	Scalable I/O input connectors

The connectors contain 16 digital input signals, 16 digital output signals, 24 V and 0 V for the outputs, and 0 V for the inputs.

For connection details, see *Circuit diagram - OmniCore V250XT*, rev 04 or later, 3HAC074000-008 and *Application manual - Scalable I/O*, 3HAC070208-001.

*Continues on next page*

## 3 Installation and commissioning

### 3.5.9 Descriptions for connectors

*Continued*

#### Conveyor tracking module (option)

For detail information on customer connections to conveyor tracking module, see *Application manual - Conveyor tracking, 3HAC066561-001*.

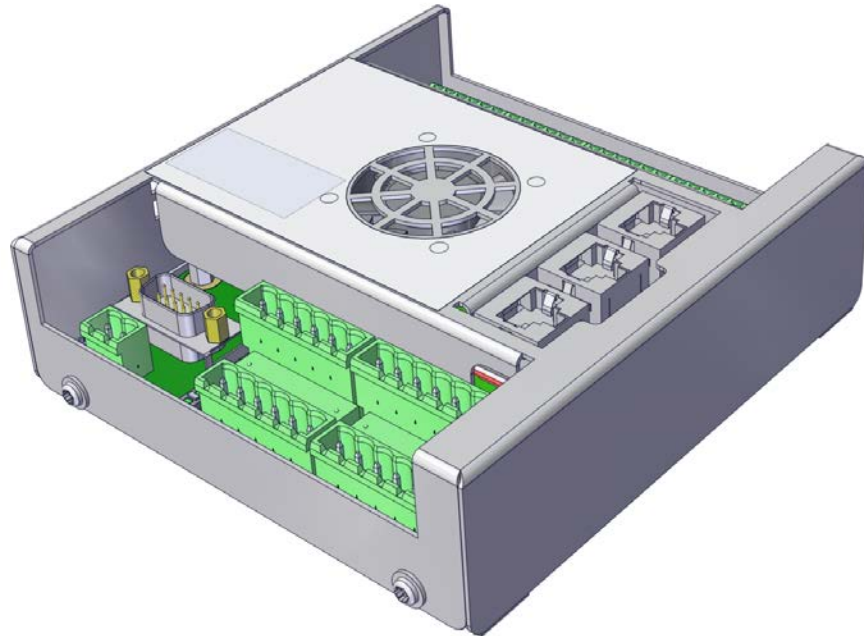

xx2100002526

#### Customer cable layout

It is recommended to use multicore cable for the customer connection. The cables connected by customer to the conveyor tracking module should go through the cable grommet and fasten on the cabinet.



#### Note

The end user needs to install proper grommets according to the diameter of the cables which need to go through the grommet.

Incorrect use of grommets will affect ingress protection, EMI/EMC and temperature.

It is recommended to use icotek KT grommet.

The cable layout is recommended as the following illustration.

#### 24V terminal block (option)

This connector is internally connected with the optional power supply. It is a 24 V power supply for the customer. The characteristics are shown in the following table.

Parameter	Value
Voltage	24 V DC

*Continues on next page*

Parameter	Value
Voltage tolerance	-3% ~ +10%
Max output current	4 A



#### Note

The 24 V terminal block power supply is isolated from the internal logical circuit of the controller.

For connection details, see *Circuit diagram - OmniCore V250XT*, rev 04 or later, 3HAC074000-008.

#### Customer cable layout

It is recommended to use multicore cable for the customer connection.

The cables connected by customer to the 24 V terminal block should go through the cable grommet and fasten on the cabinet.



#### Note

The diameter of the cables must match the diameter of the grommet.

Incorrect installation will affect the ingress protection.

It is recommended to use icotek KT grommet.

## 3 Installation and commissioning

### 3.5.10 Configuring robot stopping functions

#### 3.5.10 Configuring robot stopping functions

##### Introduction

The robot stopping functions, protective and emergency stop, are configured using the *Visual SafeMove* functionality in RobotStudio. This includes the emergency stop device on the FlexPendant, and external stop functions.

The protective stop function is configured with a *General Stop* (*G\_GeneralStop*) and an *Automatic Stop* (*A\_AutoStop*).

For the *General Stop*, the activation of the protective stop device will initiate the protective stop in any operating mode. For the *Automatic Stop*, the activation of the protective stop device will initiate the protective stop in automatic mode only.

For more information about safety configurations, see *Application manual - Functional safety and SafeMove*.

##### Configure the robot stopping functions in Visual SafeMove



#### WARNING

The new settings must be verified by test before the robot is used.



#### Note

Depending on the controller variant and RobotWare version, the configuration options are different.

Not all configurations can be modified.

Use this procedure to configure the robot stopping functions in Visual SafeMove.

- 1 In *Visual SafeMove*, select **Stop Configuration**.

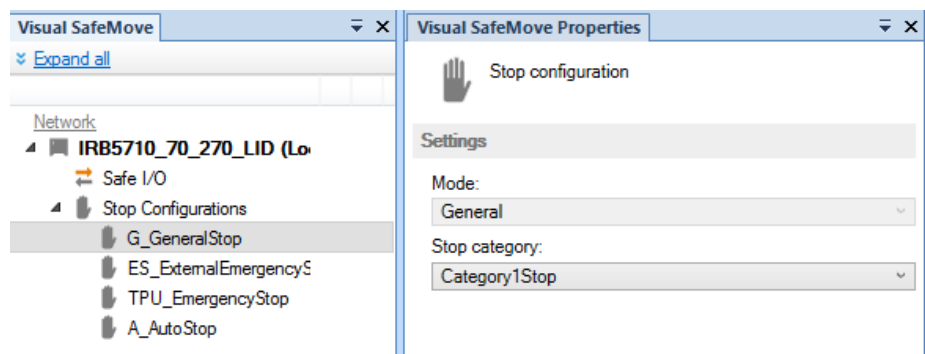

xx2300001717

- 2 Select a stop configuration or right-click to create a new configuration.
- 3 For user-created stop configurations, select the signal that should trigger the stop in the **Trigger signal** dropdown menu.
  - 0 = activate stop
  - 1 = deactivate stop

*Continues on next page*



- 4 For user-created stop configurations, if a status signal should be set when the functionality is active, select the signal to use in **Stop trigger status** dropdown menu.
 

If no output signal should be used, select **No signal**.

  - 0 = stop triggered
  - 1 = stop not triggered
- 5 Define the mode (automatic or manual).
  - *G\_GeneralStop* is the *General Stop* input
  - *ES\_ExternalEmergencyStop* is the *Emergency Stop* input

To avoid dead-lock in an emergency stop chain, the *ES\_ExternalEmergencyStop* input can be decoupled from the ES output.

  - *TPU\_EmergencyStop* is the emergency stop device on the FlexPendant
  - *A\_AutoStop* is the *Automatic Stop* input
- 6 Select the stop category.
- 7 After the configuration is done, the safety configuration must be transferred to the controller and then a restart of the controller is required.



**Tip**

See also the circuit diagram, *Circuit diagram - OmniCore V250XT*, rev 04 or later.

#### Apply the configuration to the controller

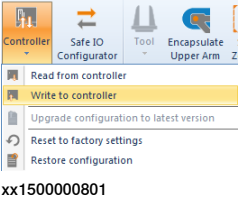
	Action	Note/illustration
1	In the <b>Visual SafeMove</b> ribbon, click on <b>Controller</b> and then select <b>Write to controller</b> .	 <p>xx1500000801</p>
2	A report of the safety configuration is shown. The report can be printed by clicking on <b>Print</b> (it is recommended to print the report since it should be used when validating the configuration). Click OK to close the report.	
3	Answer <b>Yes</b> when asked if you want to restart the controller.	After the restart, the downloaded configuration is active. Before running in auto mode, the configuration should be validated and locked, see <a href="#">Validate the configuration of robot stopping functions on page 110</a> .

*Continues on next page*

## 3 Installation and commissioning

### 3.5.10 Configuring robot stopping functions

*Continued*

#### Validate the configuration of robot stopping functions



#### **DANGER**

A stop configuration must always be validated to verify that the desired safety is achieved.

	Action	Expected result
1	Deactivate any supervision functions that are signal activated.	
2	Move the robot, for example with a move instruction.	
3	Set the signal configured to stop the robot in relevant operating modes. Relevant operating modes are: <ul style="list-style-type: none"><li>• <b>Auto:</b> Automatic mode</li><li>• <b>General:</b> All modes</li><li>• <b>EmergencyStop:</b> All modes</li></ul>	The robot will stop.

#### Set the configuration to validated

When the stop configuration is validated the configuration, the status of the configuration shall be changed to **Validated** on the FlexPendant.

- 1 Log in as a user with the grant **Safety Services**.
- 2 In the **Settings** app, select the **Safety Controller**, and then **Configuration**.
- 3 Select the check box **Validated**.

#### Set the configuration to locked

When the stop configuration is approved, the status of the configuration should be changed to **Locked** on the FlexPendant.

Running the robot in auto mode with the configuration unlocked will result in a warning message.

- 1 Log in as a user with the grant **Lock Safety Controller Configuration**.
- 2 In the **Settings** app, select the **Safety Controller**, and then **Configuration**.
- 3 Select the check box **Locked**.

#### Upgrading RobotWare

When upgrading RobotWare there can be differences in functionality, also when configuring the robot stopping functions. Always read the RobotWare release notes and verify the robot stopping functions by test after an upgrade. Contact your local ABB office for guidance.

### 3.5.11 Programmable stop functions

#### Stopping functions

There are different methods to stop the robot, in addition to manually initiated stops.

- Stop with system input signals
- Stop with RAPID instructions
- Other stops

#### Stop with system input signals

In the control system, it is possible to define system input signals to be set/reset through different interactions, for example, through networks, I/O blocks, RobAPI, etc. *See next release version.*

Pre-defined system input	Description
<i>Stop</i>	The manipulator is stopped on the path with no deviation.
<i>QuickStop</i>	This is a faster stop of the manipulator than <i>SoftStop</i> . This stop is more stressing for the mechanics than <i>SoftStop</i> . <i>QuickStop</i> ignores torque and acceleration limits.
<i>Stop at End of Cycle</i>	Stops the RAPID program when the complete program is executed, that means when the last instruction in the main routine has been completed.
<i>Stop at End of Instruction</i>	Stops program execution after the current instruction is completed.

All of these stops are performed without using the brakes, and the power is never disconnected. The program execution can be continued directly, for example by activating a start signal.

#### Stop with RAPID instructions

There are several RAPID instructions available that stops the robot.

Instruction	Description	Arguments
<code>SystemStopAction</code>	Stops all robots in all tasks immediately.	<p><code>\Stop</code>: similar to a normal program stop with stop button.</p> <p><code>\StopBlock</code>: as above, but to restart the PP has to be moved.</p> <p><code>\Halt</code>: this is like a category 0 stop, i.e. it will result in motors off state, stop of program execution and robot movements in all motion tasks. The Motors on button must be pressed before the program execution can be restarted.</p>
<code>Stop</code>	The current move instruction will be finished before the robot stops. A restart will continue the program execution.	<p><code>\NoRegain</code>: the robot will not return to the stop point when restarted, e.g. after having been jogged away.</p> <p><code>\AllMoveTasks</code>: all robots will be stopped.</p>

*Continues on next page*

### 3 Installation and commissioning

#### 3.5.11 Programmable stop functions

Continued



Instruction	Description	Arguments
StopMove	The current move instruction will be stopped immediately as a soft stop but the program execution will continue with the next instruction. This is often used in for example trap routines.	\AllMotionTasks: all robots will be stopped.
BREAK	The current move instruction and the program execution will be stopped immediately as a normal program stop. A restart will continue the program execution.	
EXIT	The current move instruction and the program execution will be stopped immediately as a normal program stop. After stop the Program Pointer has to be reset to Main.	
EXITCYCLE	The current move instruction and program execution will be stopped immediately. The Program Pointer will be reset to Main and if running mode is continuous, the program will be restarted.	
SearchX	Search instructions can be programmed with arguments to stop the robot movement close to the point where a search hit was noticed. The program execution will continue with the next instruction.	<p>\Stop: Stiff stop - the robot will stop as fast as possible. This stop is performed by ramping down motion in each motor separate from each other, and as fast as possible. Since it will be without any coordination, the robot may slide off path fairly much.</p> <p>\SStop: Soft stop - the robot will stop on path.</p> <p>\Sup: the robot will continue to the ToPoint. If more than one search hit is found, an error will be reported.</p>

RAPID instructions are described in *Technical reference manual - RAPID Instructions, Functions and Data types*.

#### Other unexpected stops

Type of stop	Description
SysFail	In the control system there is a surveillance and monitoring function that can detect abnormal situations. In such cases a stop will be initiated. The robot controller must be restarted, and the configuration may have to be changed.
Power fail	In the control system there is a monitoring function that can detect power failure. At power fail, all execution will be stopped. After powerOn/motorsOn, it is possible to restart and continue the execution where it stopped.

Continues on next page

Type of stop	Description
Stop at collision	<p>In the control system there is a monitoring function that can detect collisions. When a collision is detected, a stop will be initiated.</p> <p>This functionality can be switched on/off using the system parameters for Motion/Motion Supervision.</p> <p> <b>WARNING</b></p> <p>Special care must be taken when restarting a machine that is stopped due to a collision. The robot might make a limited movement when restarted.</p> <p> <b>WARNING</b></p> <p>The revolution counters might need to be updated after a collision to ensure path accuracy.</p>

#### Stopping time/distance

Stopping time and distance metric for stop category 0 and stop category 1 are detailed in the product specification for the respective manipulator.

The data is valid for floor mounted manipulators, without any tilting.

### 3 Installation and commissioning

#### 3.6.1 Available industrial networks

### 3.6 I/O system

#### 3.6.1 Available industrial networks

##### General



##### Note

Two industrial network masters can be run in parallel on the OmniCore controller. It is the responsibility of the integrator to verify the behavior when two masters are used in one OmniCore.

##### Fieldbus connections

There is a slot available for installing a DeviceNet M/S board on the main computer. The software based fieldbuses are connected directly to one of the Ethernet ports.

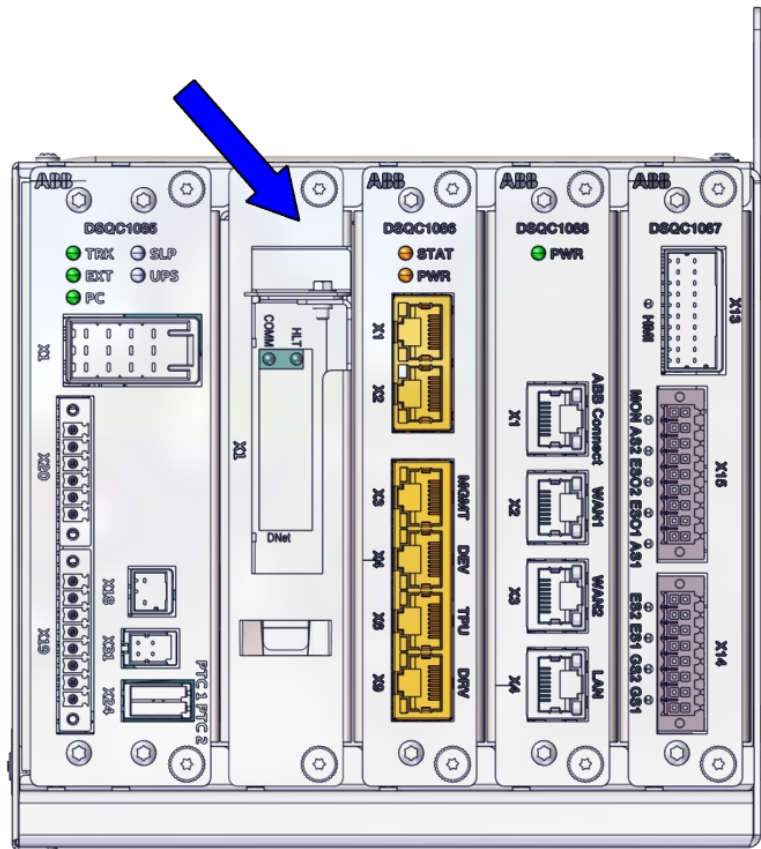

xx2300001738

##### Available board

The following master board is available.

Description	Article number	Type designation
DeviceNet M/S	3HAC085254-001	DSQC1096

Continues on next page

#### Available software based fieldbuses

The following software based fieldbuses are available as RobotWare options.

- EtherNet/IP
- PROFINET
- CC-Link IE Field Basic

---

#### References

For more information on how to install and configure the fieldbuses, see the respective manual.

Manual title	Article number
<i>Application manual - EtherNet/IP Scanner/Adapter</i>	<i>3HAC066565-001</i>
<i>Application manual - PROFINET Controller/Device</i>	<i>3HAC066558-001</i>
<i>Application manual - I/O Engineering</i>	<i>3HAC082346-001</i>
<i>Application manual - CC-Link IE Field Basic</i>	<i>3HAC082295-001</i>

## 3 Installation and commissioning

---

### 3.6.2 Scalable I/O, internal and external

#### 3.6.2 Scalable I/O, internal and external

---

##### General

The controller can be fitted with an I/O base unit, DSQC1030, providing 16 digital inputs and 16 digital outputs. If more I/O is needed, additional I/O units can be attached to the I/O base unit.

---

##### Scalable I/O units

The I/O unit *DSQC1030 Digital Base* belongs to the ABB Scalable I/O system, which is a modular, compact, and scalable I/O system that consists of a base device (minimum configuration), and add-on devices.

The *DSQC1042 Safety Digital Base* is a device that can be used to control and monitor machine safety equipment. The device can be used together with the scalable I/O units.

For information about configuring and using the scalable I/O devices, see *Application manual - Scalable I/O*.

For information about installing the scalable I/O devices, see [Installing the scalable I/O devices on page 117](#).



## 3.7 Installing options

### 3.7.1 Installing the scalable I/O devices

#### Location

The location of the base unit used as a scalable I/O internal unit is shown in the following illustration.

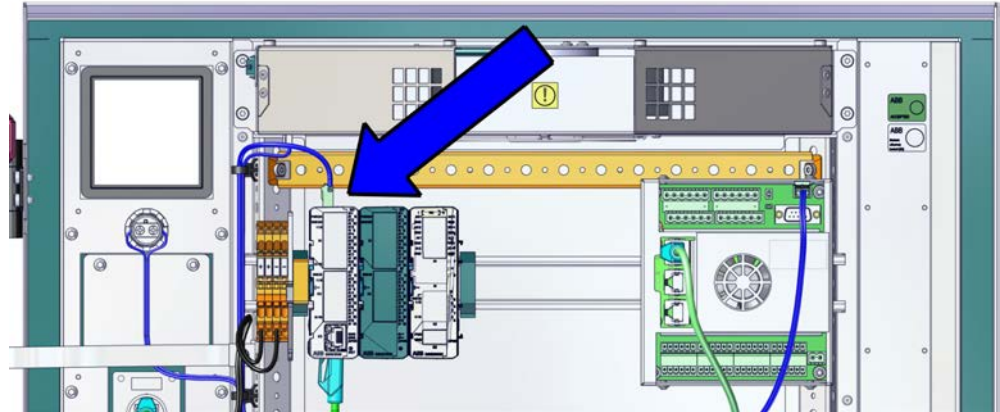

xx2300001818

The base unit can also be used as a scalable I/O external unit, with or without add-on devices.

For more information about installing, configuring, and using the scalable I/O units, see *Application manual - Scalable I/O*.

#### Required parts

Part	Article number	Note
Local I/O Digital base [3032-1]	3HAC058663-001	DSQC1030
Connectors digital base/add on	3HAC060919-001	
Digital add-on [3033-2]	3HAC058664-001	DSQC1031
Analog add-on [3034-2]	3HAC058665-001	DSQC1032
Connectors I/O Analog	3HAC060925-001	
Relay add-on [3035-2]	3HAC058666-001	DSQC1033
Connectors I/O Relay	3HAC060926-001	

#### Required tools and equipment

Equipment	Article number	Note
Standard toolkit	-	Content is defined in section <a href="#">Standard toolkit for controller on page 436</a> .
ESD protective wrist band	-	

*Continues on next page*

### 3 Installation and commissioning



#### 3.7.1 Installing the scalable I/O devices

Continued

#### Required documents

Document	Article number	Note
Circuit diagram - OmniCore V250XT, rev 04 or later	3HAC074000-008	
Application manual - Scalable I/O	3HAC070208-001	

#### Installing the scalable I/O internal base device

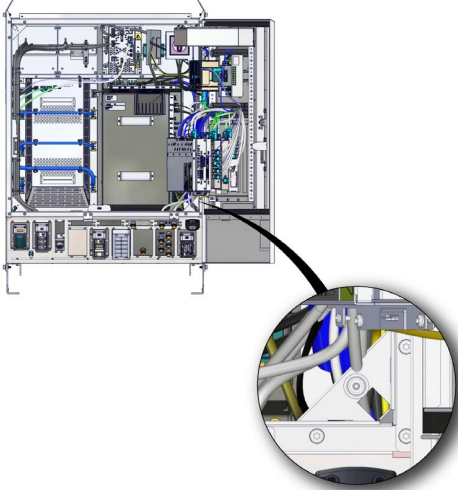
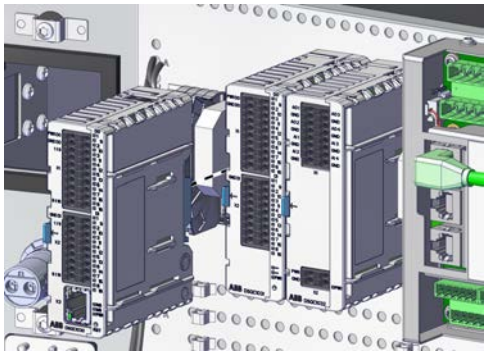

	Action	Note/Illustration
1	 <p><b>DANGER</b></p> <p>Before doing any work inside the cabinet, disconnect the mains power. For more information, see <a href="#">Electrical safety on page 29</a>.</p>	
2	 <p><b>ELECTROSTATIC DISCHARGE (ESD)</b></p> <p>The unit is sensitive to ESD. Before handling the unit read the safety information in section <a href="#">The unit is sensitive to ESD on page 45</a>.</p>	<p>Location of wrist strap button:</p>  <p>xx2200001817</p>
3	<p>Push the digital base into the bracket until you hear a clear clicking sound.</p>	 <p>xx1900002447</p>

Continues on next page

	Action	Note/Illustration
4	<p>Connect the adapter cable to the digital base.</p> <ul style="list-style-type: none"> <li>• K5.1.X5/K3.1.X5 - A2.X4/K4.X7</li> </ul> <p> <b>Note</b></p> <p>If the Ethernet extension switch is installed, connect and disconnect the connector K5.1.X5/K3.1.X5 to/from K4.X7.</p> <p>If the Ethernet extension switch is not installed, connect and disconnect the connector K5.1.X5/K3.1.X5 to/from A2.X4.</p> <ul style="list-style-type: none"> <li>• K5.1.X4 - A2.X3</li> <li>• The harness connected to I/O unit by customer</li> </ul>	

#### Installing scalable I/O external devices

For more information about installing, configuring, and using the scalable I/O units, see *Application manual - Scalable I/O*.

	Action	Note/Illustration
1	<p> <b>DANGER</b></p> <p>Before doing any work inside the cabinet, disconnect the mains power. For more information, see <a href="#">Electrical safety on page 29</a>.</p>	
2	<p> <b>ELECTROSTATIC DISCHARGE (ESD)</b></p> <p>The unit is sensitive to ESD. Before handling the unit read the safety information in section <a href="#">The unit is sensitive to ESD on page 45</a>.</p>	
3	<p>Prepare the scalable I/O units for external mounting as described in <i>Application manual - Scalable I/O</i>.</p>	
4	<p>Open the door.</p>	<p><a href="#">Opening the door on page 188</a>.</p>
5	<p>Connect the external base device to the internal base device (X3) or the Ethernet switch, using an Ethernet cable.</p>	
6	<p>Connect an external power supply to the external base units, connector X4.</p>	<p>Each base device requires its own power supply.</p>
7	<p>Close the door.</p>	<p><a href="#">Closing the door on page 189</a>.</p>
8	<p>Perform the function tests to verify that the safety features work properly, see <a href="#">Function tests on page 177</a>.</p>	

### 3 Installation and commissioning

#### 3.7.2 Installing the safety digital base device

#### 3.7.2 Installing the safety digital base device

##### Location

The illustration shows the location of the safety digital base device in the controller.

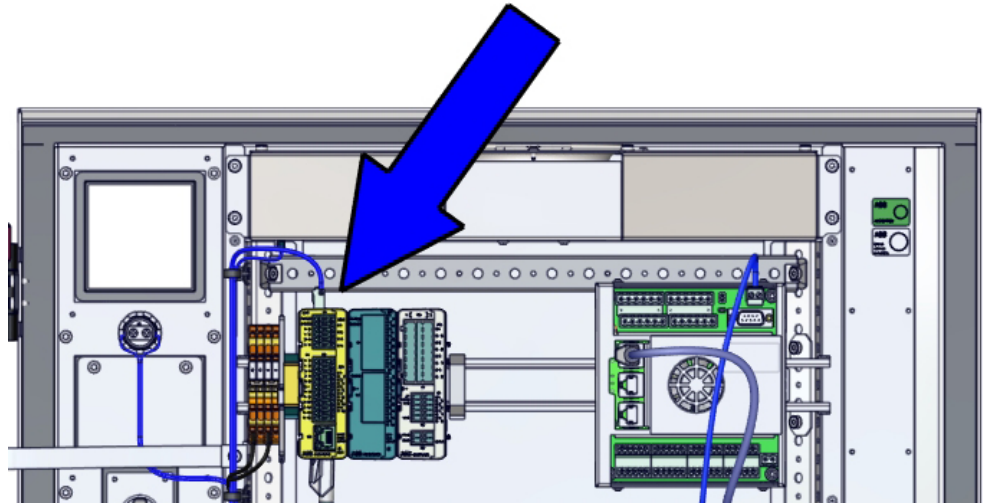

xx2300001819

##### Required spare parts



##### Note

The spare part numbers that are listed in the table can be out of date. See the latest spare parts of the OmniCore V250XT Type B via myABB Business Portal, [www.abb.com/myABB](http://www.abb.com/myABB).

Spare part	Article number	Note
Safe I/O base unit	3HAC062908-001	DSQC1042
Connectors Safety I/O	3HAC069538-001	

##### Required tools and equipment

Equipment	Article number	Note
Standard toolkit	-	Content is defined in section <a href="#">Standard toolkit for controller on page 436</a> .
ESD protective wrist band	-	





##### Required documents

Document	Article number	Note
<i>Circuit diagram - OmniCore V250XT</i> , rev 04 or later	3HAC074000-008	

Continues on next page

#### Installing the safety digital base device

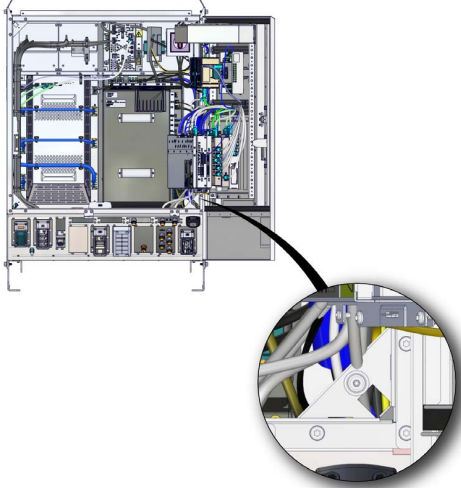
##### Fitting the safety digital base device

	Action	Note/Illustration
1	 <p><b>DANGER</b></p> <p>Before doing any work inside the cabinet, disconnect the mains power. For more information, see <a href="#">Electrical safety on page 29</a>.</p>	
2	 <p><b>ELECTROSTATIC DISCHARGE (ESD)</b></p> <p>The unit is sensitive to ESD. Before handling the unit read the safety information in section <a href="#">The unit is sensitive to ESD on page 45</a>.</p>	<p>Location of wrist strap button:</p>  <p>xx2200001817</p>
3	<p>Push the digital base into the bracket until you hear a clear clicking sound.</p>	 <p>xx2200001972</p>

*Continues on next page*

### 3 Installation and commissioning

#### 3.7.2 Installing the safety digital base device

Continued

	Action	Note/Illustration
4	<p>Connect the adapter cable to the digital base.</p> <ul style="list-style-type: none"><li>• K5.1.X5/K3.1.X5 - A2.X4/K4.X7</li></ul> <p> <b>Note</b></p> <p>If the Ethernet extension switch is installed, connect and disconnect the connector K5.1.X5/K3.1.X5 to/from K4.X7.</p> <p>If the Ethernet extension switch is not installed, connect and disconnect the connector K5.1.X5/K3.1.X5 to/from A2.X4.</p> <ul style="list-style-type: none"><li>• K5.1.X4 - A2.X3</li><li>• The harness connected to I/O unit by customer</li></ul>	

#### Concluding procedure

	Action	Note/Illustration
1	Close the door.	<a href="#">Closing the door on page 189.</a>
2	Perform the function tests to verify that the safety features work properly, see <a href="#">Function tests on page 177.</a>	

### 3.7.3 Installing the Ethernet extension switch

#### Location

The illustration shows the location of the Ethernet extension switch in the controller.

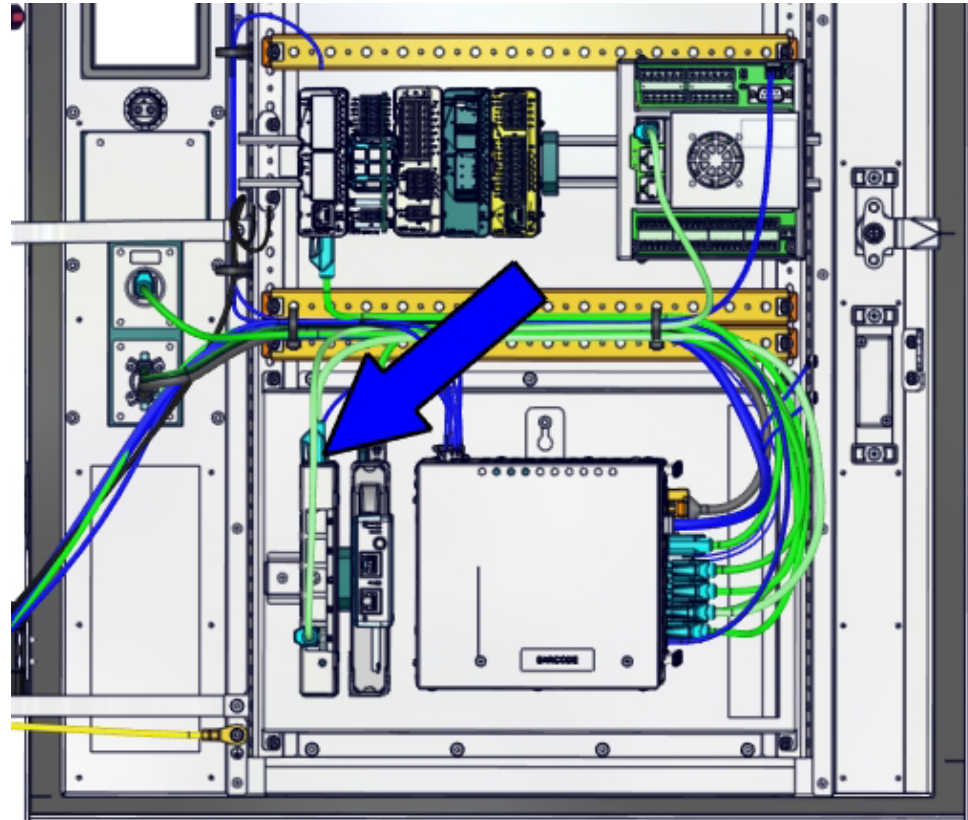

xx2300001820

#### Required spare parts



#### Note

The spare part numbers that are listed in the table can be out of date. See the latest spare parts of the OmniCore V250XT Type B via myABB Business Portal, [www.abb.com/myABB](http://www.abb.com/myABB).

Spare part	Article number	Note
Ethernet Extension switch [3014-1]	3HAC059187-001	DSQC1035
Ethernet Harness	3HAC084152-001	Harness A2.X4 - K4.X6

#### Required tools and equipment

Equipment	Article number	Note
Standard toolkit	-	Content is defined in section <a href="#">Standard toolkit for controller on page 436</a> .

*Continues on next page*



### 3 Installation and commissioning

#### 3.7.3 Installing the Ethernet extension switch

*Continued*



Equipment	Article number	Note
ESD protective wrist band	-	

#### Required documents

Document	Article number	Note
<i>Circuit diagram - OmniCore V250XT, rev 04 or later</i>	3HAC074000-008	

#### Installing the Ethernet extension switch

##### Preparations

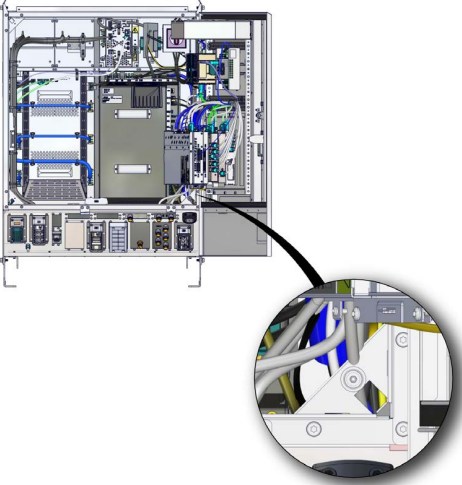
	Action	Note/Illustration
1	 <b>DANGER</b> Before doing any work inside the cabinet, disconnect the mains power. For more information, see <a href="#">Electrical safety on page 29</a> .	
2	Open the door.	<a href="#">Opening the door on page 188</a> .
3	 <b>ELECTROSTATIC DISCHARGE (ESD)</b> The unit is sensitive to ESD. Before handling the unit read the safety information in section <a href="#">The unit is sensitive to ESD on page 45</a> .	Location of wrist strap button:  xx2200001817

##### Refitting the Ethernet extension switch (option)

	Action	Note/Illustration
1	 <b>DANGER</b> Before doing any work inside the cabinet, disconnect the mains power. For more information, see <a href="#">Electrical safety on page 29</a> .	



*Continues on next page*



### 3 Installation and commissioning

#### 3.7.3 Installing the Ethernet extension switch

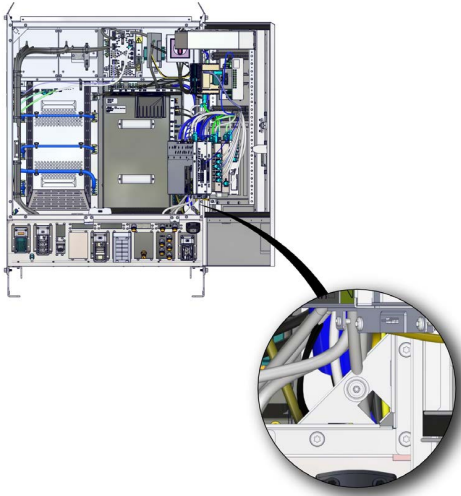
Continued

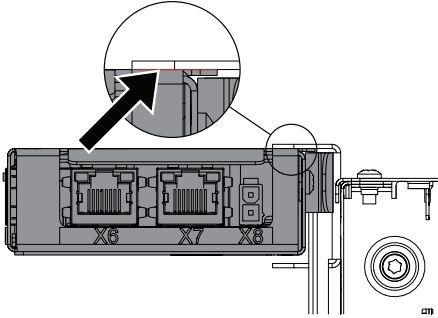
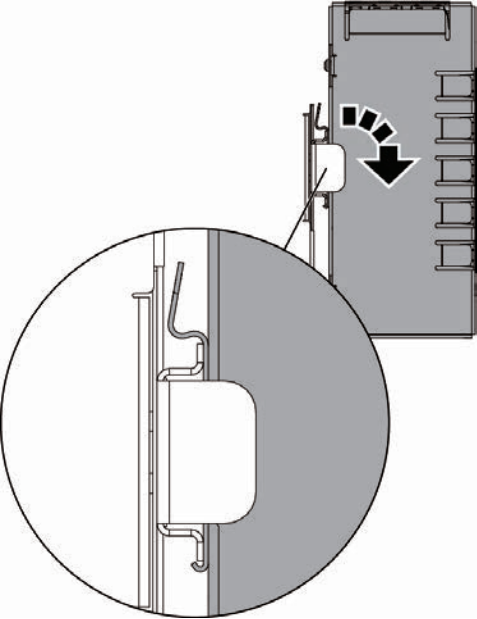
	Action	Note/Illustration
2	<p> <b>ELECTROSTATIC DISCHARGE (ESD)</b></p> <p>The unit is sensitive to ESD. Before handling the unit read the safety information in section <a href="#">The unit is sensitive to ESD on page 45</a>.</p>	<p>Location of wrist strap button:</p>  <p>xx2200001817</p>
3	<p>Hook up the Ethernet extension switch to the bracket and then push the switch into position.</p> <p> <b>Note</b></p> <p>During the installation, there should be no gap between the upper surface of the Ethernet extension switch and the lower surface of highest bracket on the main computer.</p>  <p>xx1800000972</p>	 <p>xx2300001835</p>
4	<p>Reconnect any connectors disconnected at removal.</p>	

#### Concluding procedure

	Action	Note/Illustration
1	<p>Close the door.</p>	<p><a href="#">Closing the door on page 189</a>.</p>
2	<p>Perform the function tests to verify that the safety features work properly, see <a href="#">Function tests on page 177</a>.</p>	

### 3 Installation and commissioning

#### 3.7.4 Installing additional drive units

#### 3.7.4 Installing additional drive units

##### General

The following sections describe the standard installation of additional drive units. For more complex configurations please contact ABB.

For information about additional axes, see *Application manual - Additional axes*.



##### Note

Make sure the robot software is configured to reflect the drive functions installed.

##### Additional axis brake snubber

Each time a motor brake is engaged, there will be an inductive kickback, that is a rapid change in voltage across the brake terminals. This is a result of the inherent inductance of the brake circuit.

For robots, this inductive kickback is handled by individual snubbers at each motor and at the brake release board in the robot.

ABB products such as Track Motion, Positioners, Motor Units, Gear Units are equipped with integrated brake snubbers.

When integrating a motor not delivered by ABB, it is of great importance that the motor has a snubber fitted across the brake terminals, at the motor. Failure to do so will void warranty and may result in drive unit failure.

The maximum allowed voltage across the brake terminals is 65V.

The following illustration shows possible implementations of snubber circuits:

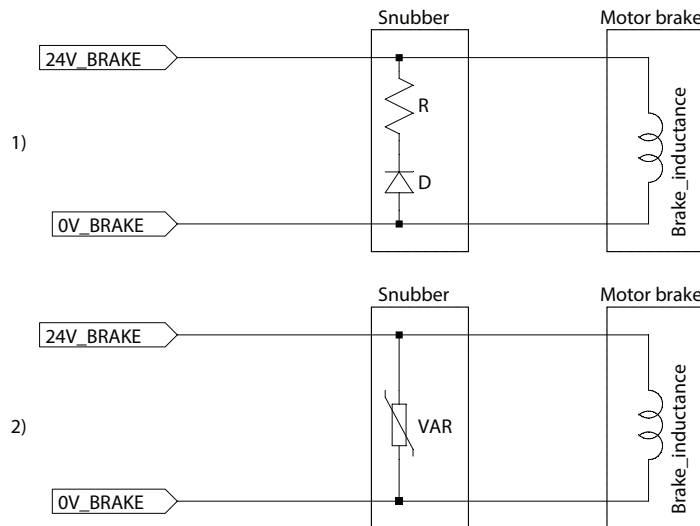

xx2200001374

1	The resistor in this snubber circuit may be omitted. The diode should be dimensioned for the same current as the relay coil, and a voltage of at least twice the brake release voltage.
2	The varistor should be dimensioned for the same energy as the brake coil.

Continues on next page

#### Location

The illustration shows the location of the additional drive unit in the controller.

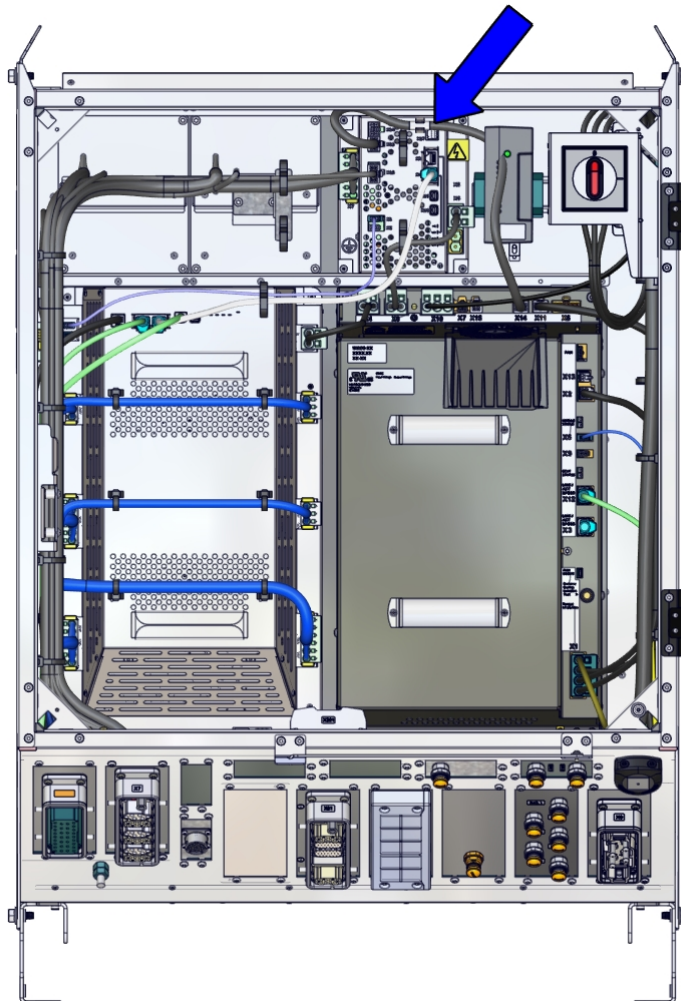

xx2200001056



#### WARNING

Do not touch the drive unit when the DC-BUS High Voltage LED is on.  
There is residual voltage in the drive unit even if the main switch is in the OFF position.

#### Required spare parts



#### Note

The spare part numbers that are listed in the table can be out of date. See the latest spare parts of the OmniCore V250XT Type B via myABB Business Portal, [www.abb.com/myABB](http://www.abb.com/myABB).

*Continues on next page*

### 3 Installation and commissioning

#### 3.7.4 Installing additional drive units

Continued

Spare part	Article number	Note
Drive unit	3HAC064983-001	DSQC 3065

#### Required tools and equipment



Equipment	Article number	Note
Standard toolkit	-	Content is defined in section <a href="#">Standard toolkit for controller on page 436</a> .
ESD protective wrist band	-	

#### Required documents

Document	Article number	Note
<i>Circuit diagram - OmniCore V250XT, rev 04 or later</i>	3HAC074000-008	

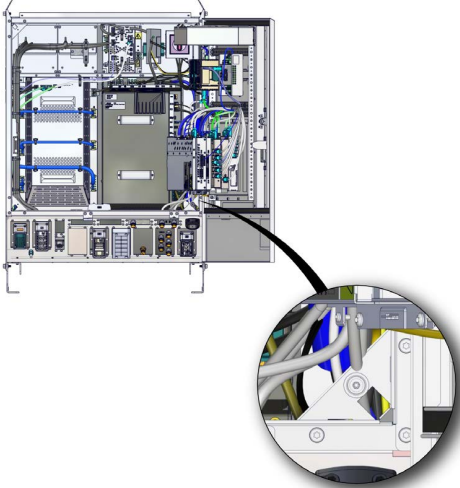

#### Installing the additional drive unit

##### Preparations

Action	Note/Illustration
<p>1</p>  <p><b>DANGER</b></p> <p>Before doing any work inside the cabinet, disconnect the mains power. For more information, see <a href="#">Electrical safety on page 29</a>.</p>	
<p>2</p> <p>Open the door.</p>	<a href="#">Opening the door on page 188</a> .
<p>3</p>  <p><b>ELECTROSTATIC DISCHARGE (ESD)</b></p> <p>The unit is sensitive to ESD. Before handling the unit read the safety information in section <a href="#">The unit is sensitive to ESD on page 45</a>.</p>	<p>Location of wrist strap button:</p>  <p>xx2200001817</p>

Continues on next page

#### Installing the additional drive unit

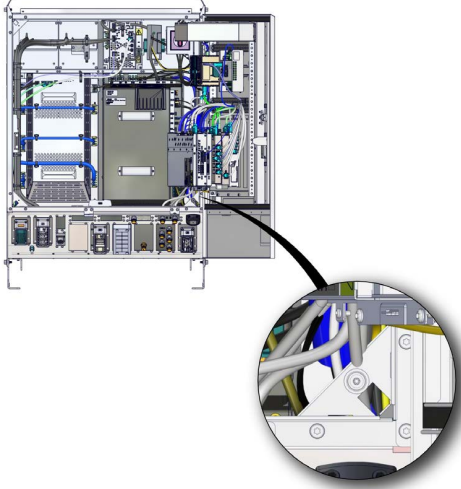
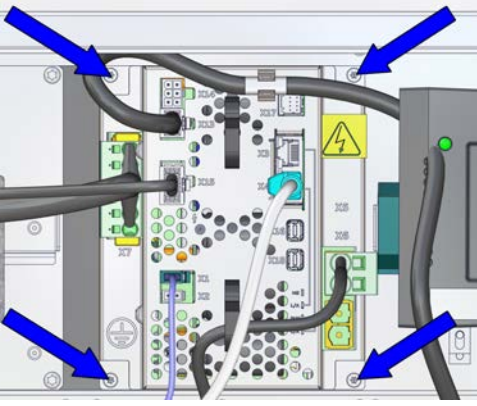
	Action	Note/Illustration
1	 <p><b>DANGER</b></p> <p>Before doing any work inside the cabinet, disconnect the mains power. For more information, see <a href="#">Electrical safety on page 29</a>.</p>	
2	 <p><b>ELECTROSTATIC DISCHARGE (ESD)</b></p> <p>The unit is sensitive to ESD. Before handling the unit read the safety information in section <a href="#">The unit is sensitive to ESD on page 45</a>.</p>	<p>Location of wrist strap button:</p>  <p>xx2200001817</p>
3	<p>Fit the additional drive unit and secure with the screws.</p>	<p>Screws: Torx pan head screw M4x8 (4 pcs) Tightening torque: 2 Nm</p>  <p>xx2200001375</p>
4	<p>Connect:</p> <ul style="list-style-type: none"> <li>• T4.X7 -X12, T4.X15</li> <li>• T4.X17 - A1.X2</li> <li>• T4.X13 - A1.X11</li> <li>• T4.X5 - A1.X4</li> <li>• T4.X3 - A1.X12</li> <li>• T4.X1 - A1.X5</li> </ul>	

*Continues on next page*

### 3 Installation and commissioning

---

#### 3.7.4 Installing additional drive units

*Continued*

Concluding procedure

	Action	Note/Illustration
1	Close the door.	<a href="#">Closing the door on page 189.</a>
2	Perform the function tests to verify that the safety features work properly, see <a href="#">Function tests on page 177.</a>	

#### 3.7.5 Installing the power supply optional device

##### Location

The illustration shows the location of the power supply optional device in the controller.

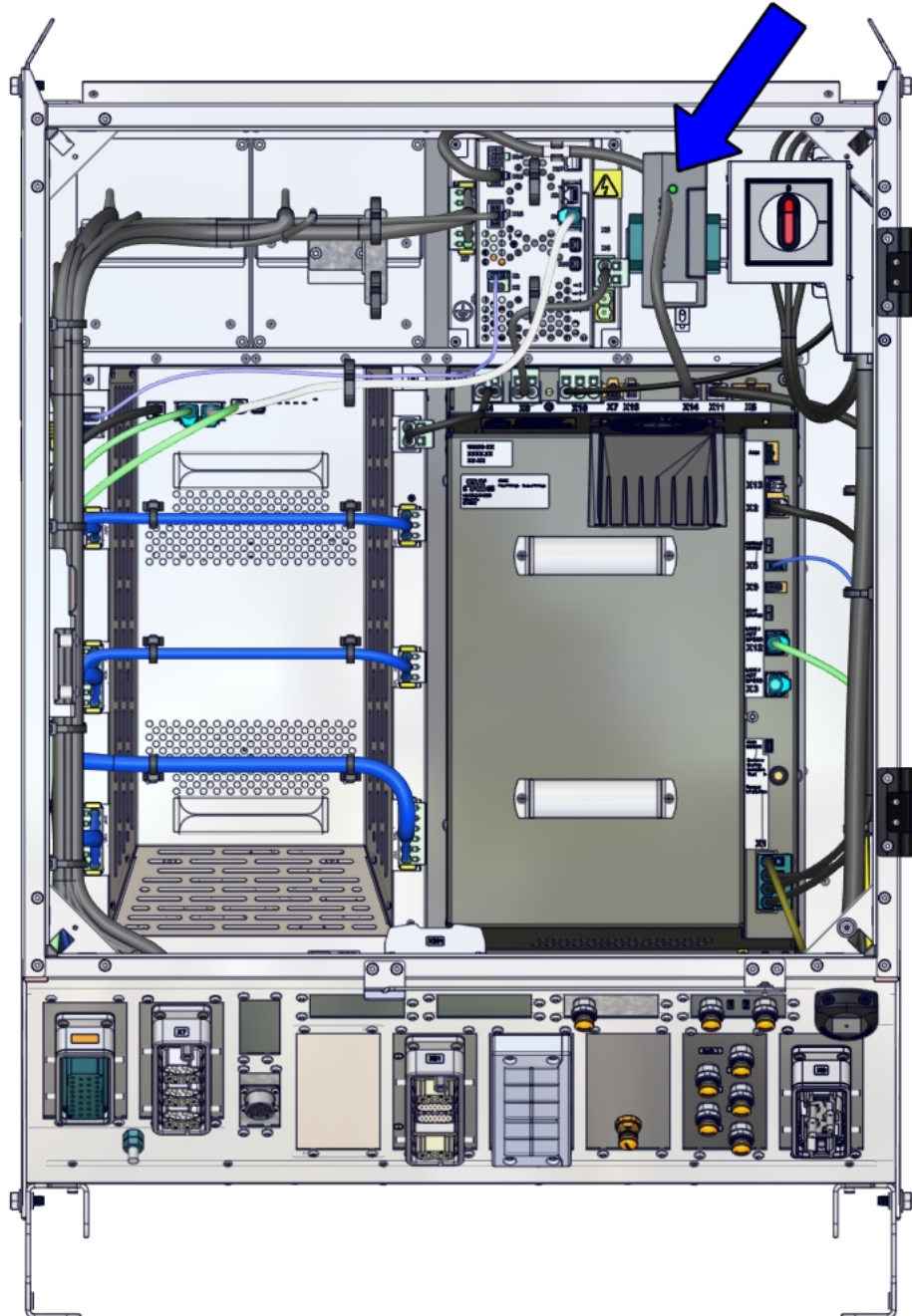

xx2200001473

*Continues on next page*



### 3 Installation and commissioning

#### 3.7.5 Installing the power supply optional device

Continued

#### Required spare parts



#### Note

The spare part numbers that are listed in the table can be out of date. See the latest spare parts of the OmniCore V250XT Type B via myABB Business Portal, [www.abb.com/myABB](http://www.abb.com/myABB).

Spare part	Article number	Note
DSQC 609 power supply	3HAC14178-1	DSQC 609
DSQC 634 power supply	3HAC13398-2	DSQC 634
Harness PSU 24V	3HAC082083-001	DSQC 609 and DSQC 634
Harness PSU	3HAC082508-001	DSQC 609 and DSQC 634
End clamp	3HAB7983-1	

#### Required tools and equipment

Equipment	Article number	Note
Standard toolkit	-	Content is defined in section <a href="#">Standard toolkit for controller on page 436</a> .
ESD protective wrist band	-	

#### Required documents

Document	Article number	Note
<i>Circuit diagram - OmniCore V250XT</i> , rev 04 or later	3HAC074000-008	

#### Installing the optional power supply

##### Preparations

	Action	Note/Illustration
1	 <b>DANGER</b> Before doing any work inside the cabinet, disconnect the mains power. For more information, see <a href="#">Electrical safety on page 29</a> .	
2	Open the door.	<a href="#">Opening the door on page 188</a> .

Continues on next page



### 3 Installation and commissioning

#### 3.7.5 Installing the power supply optional device

*Continued*

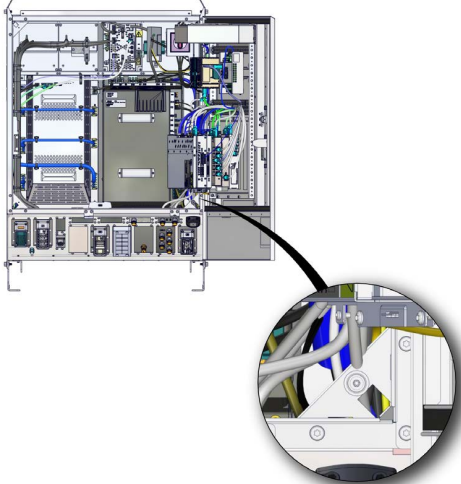
	Action	Note/Illustration
3	<p> <b>ELECTROSTATIC DISCHARGE (ESD)</b></p> <p>The unit is sensitive to ESD. Before handling the unit read the safety information in section <i>The unit is sensitive to ESD on page 45</i>.</p>	<p>Location of wrist strap button:</p>  <p>xx2200001817</p>

#### Installing the 24V terminal block

	Action	Note/Illustration
1	<p>Hang the 24V terminal block to the bracket and push the lower part until you hear a clear clicking sound.</p>	

*Continues on next page*

### 3 Installation and commissioning

#### 3.7.5 Installing the power supply optional device

*Continued*

##### Fitting the optional power supply

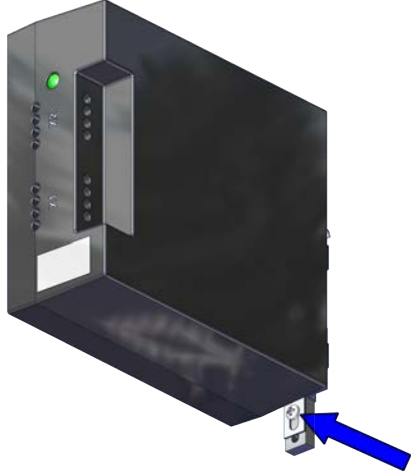
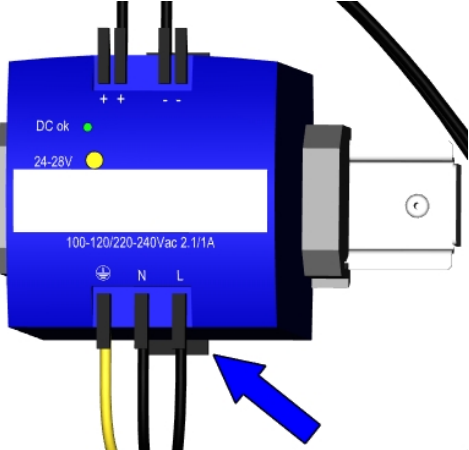
	Action	Note/Illustration
1	<p>Fit the power supply to the bracket.</p> <p> <b>Note</b></p> <p>For DSQC 609: Hang the power supply to the bracket and secure the power supply with the attached screw.</p> <p>For DSQC 634: Hang the power supply to the bracket and push the lower part until you hear a clear clicking sound.</p>	<p>For DSQC 609: Screws: Cross recessed cheese head screw M4x8 (1 pcs)</p>  <p>xx1900001908</p> <p>For DSQC 634:</p>  <p>xx2200002012</p>

*Continues on next page*

### 3 Installation and commissioning

#### 3.7.5 Installing the power supply optional device

*Continued*

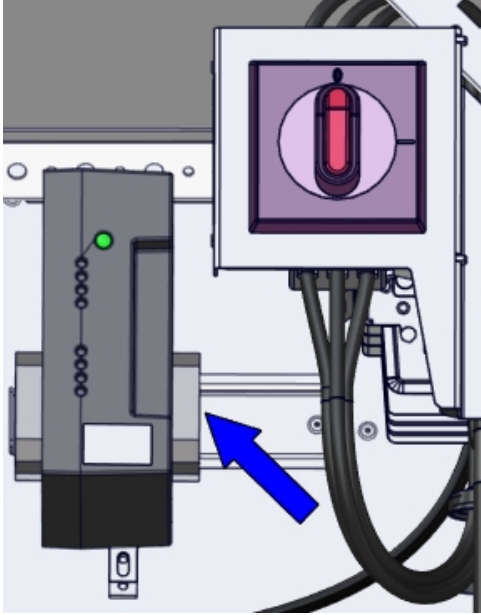
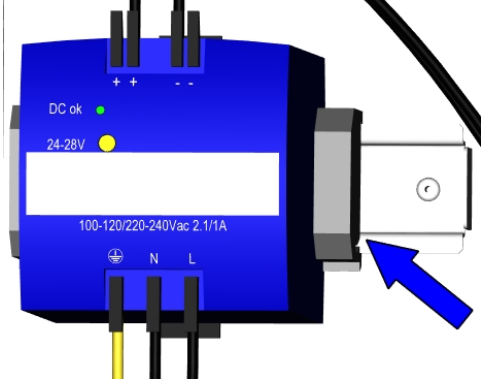
	Action	Note/Illustration
2	Refit the end clamp besides the power supply.	<p>For DSQC 609:</p>  <p>xx2200002009</p> <p>For DSQC 634:</p>  <p>xx2200002011</p>
3	<p>Connect:</p> <ul style="list-style-type: none"> <li>• T5.X1-A1.X7 Terminal block</li> <li>• T8.X1-A1.X15 Terminal block</li> <li>• T6.X1-A1.X7 Terminal block</li> <li>• T9.X1-A1.X15 Terminal block</li> <li>• T5.X2-24V Terminal block</li> <li>• T8.X2-24V Terminal block</li> <li>• T6.X2-24V Terminal block</li> <li>• T9.X2-24V Terminal block</li> </ul>	

#### Concluding procedure

	Action	Note/Illustration
1	Close the door.	<a href="#">Closing the door on page 189.</a>

*Continues on next page*

### 3 Installation and commissioning

---

#### 3.7.5 Installing the power supply optional device

*Continued*

	Action	Note/Illustration
2	Perform the function tests to verify that the safety features work properly, see <a href="#">Function tests on page 177</a> .	

#### 3.7.6 Installing the conveyor tracking module (CTM)

##### Overview

The conveyor tracking module uses network communication to share conveyor speed and position data with one or more robot controllers. It contains a WAN port, which is used to connect to the robot controllers and two LAN ports that can be used for installation and service purposes.

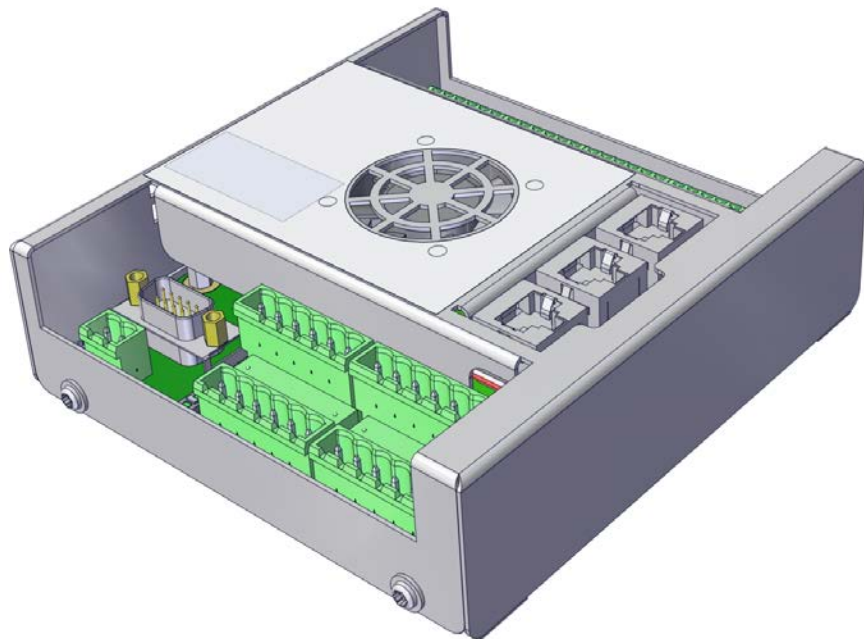

xx2100002526

##### Required parts



##### Note

The spare part numbers that are listed in the table can be out of date. See the latest spare parts of the OmniCore V250XT Type B via myABB Business Portal, [www.abb.com/myABB](http://www.abb.com/myABB).

Spare part	Article number	Note
Conveyor tracking module [3103-1]	3HNA027579-001	DSQC2000
CONNECTOR KIT - DSQC2000	3HNA029345-001	
Harness 24V_CTM	3HAC069618-001	Power cable of CTM

*Continues on next page*

### 3 Installation and commissioning

#### 3.7.6 Installing the conveyor tracking module (CTM)

Continued



#### Required tools and equipment

Equipment	Article number	Note
Standard toolkit	-	Content is defined in section <a href="#">Standard toolkit for controller on page 436</a> .
ESD protective wrist band	-	

#### Required documents

Document	Article number	Note
<i>Circuit diagram - OmniCore V250XT</i> , rev 04 or later	3HAC074000-008	
<i>Application manual - Conveyor tracking</i>	3HAC066561-001	

#### Installing the conveyor tracking module

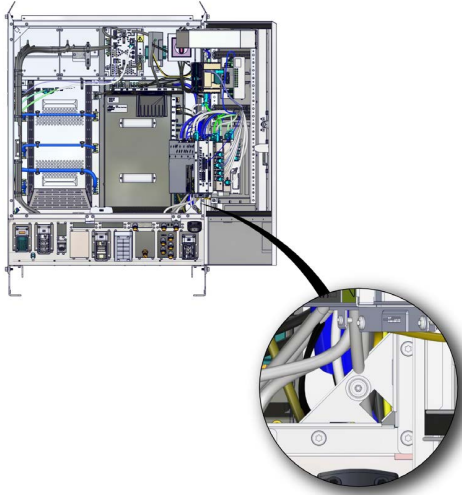
	Action	Note/Illustration
1	 <b>DANGER</b> Before doing any work inside the cabinet, disconnect the mains power. For more information, see <a href="#">Electrical safety on page 29</a> .	
2	 <b>ELECTROSTATIC DISCHARGE (ESD)</b> The unit is sensitive to ESD. Before handling the unit read the safety information in section <a href="#">The unit is sensitive to ESD on page 45</a> .	Location of wrist strap button:  xx2200001817
3	Open the door.	<a href="#">Opening the door on page 188</a> .

Continues on next page

### 3 Installation and commissioning

#### 3.7.6 Installing the conveyor tracking module (CTM)

*Continued*

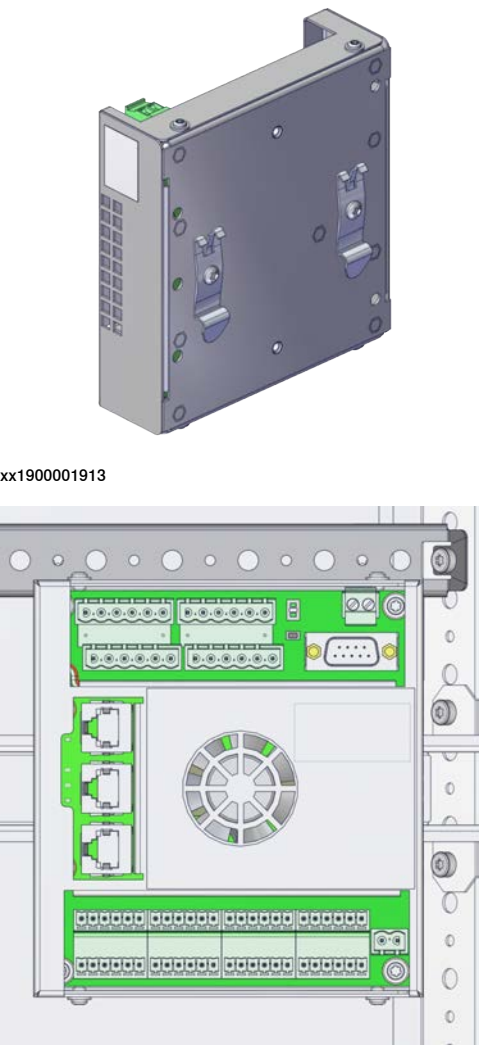
	Action	Note/Illustration
4	Fit the conveyor tracking module and push the lower part until you hear a clear clicking sound.	 <p>xx1900001913</p> <p>xx2200001844</p>
5	Connect: <ul style="list-style-type: none"> <li>• B1.X7 - K4.X1-X5</li> </ul>	
6	Connect wires to the input and output connectors as required.	See <i>Application manual - Conveyor tracking</i> .
7	Close the door.	<a href="#">Closing the door on page 189</a> .
8	Perform the function tests to verify that the safety features work properly, see <a href="#">Function tests on page 177</a> .	

For more information about the option *Conveyor Tracking*, see *Application manual - Conveyor tracking*.

### 3 Installation and commissioning

#### 3.7.7 Installing the cable grommet assembly

#### 3.7.7 Installing the cable grommet assembly

##### Location

The illustration shows the location of the cable grommet assembly on the controller.

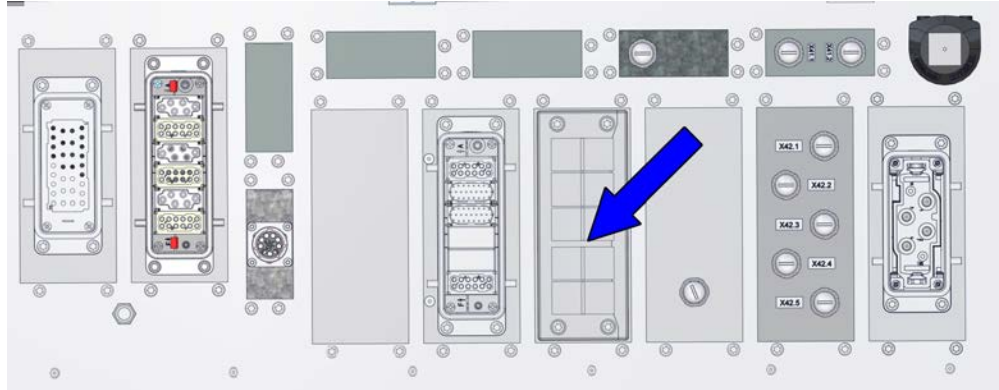

xx2200002163



##### Note

The end user needs to install proper grommets according to the diameter of the cables which need to go through the grommet.

Incorrect use of grommets will affect ingress protection, EMI/EMC and temperature.

It is recommended to use icotek KT grommet.

##### Required spare parts



##### Note

The spare part numbers that are listed in the table can be out of date. See the latest spare parts of the OmniCore V250XT Type B via myABB Business Portal, [www.abb.com/myABB](http://www.abb.com/myABB).

Spare part	Article number	Note
Cable grommet asm	3HAC066396-001	

##### Required tools and equipment

Equipment	Article number	Note
Standard toolkit	-	Content is defined in section <a href="#">Standard toolkit for controller on page 436</a> .
ESD protective wrist band	-	

Continues on next page



### 3 Installation and commissioning

#### 3.7.7 Installing the cable grommet assembly



*Continued*

#### Required documents

Document	Article number	Note
Circuit diagram - OmniCore V250XT, rev 04 or later	3HAC074000-008	

#### Installing cables with the cable grommet assembly

#### Preparations

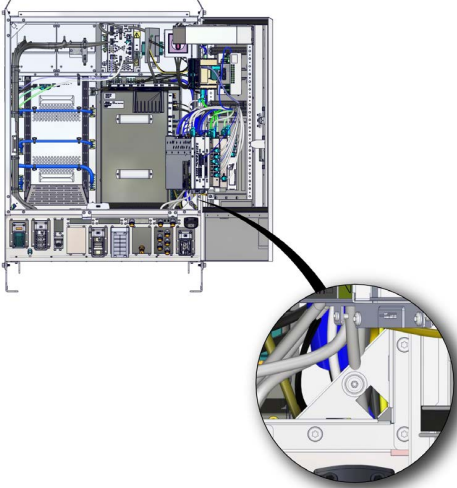
	Action	Note/Illustration
1	 <b>DANGER</b> Before doing any work inside the cabinet, disconnect the mains power. For more information, see <a href="#">Electrical safety on page 29</a> .	
2	Open the door.	<a href="#">Opening the door on page 188</a> .
3	 <b>ELECTROSTATIC DISCHARGE (ESD)</b> The unit is sensitive to ESD. Before handling the unit read the safety information in section <a href="#">The unit is sensitive to ESD on page 45</a> .	Location of wrist strap button:  xx2200001817

*Continues on next page*

### 3 Installation and commissioning

#### 3.7.7 Installing the cable grommet assembly

*Continued*

##### Removing the slot cover (baseline)

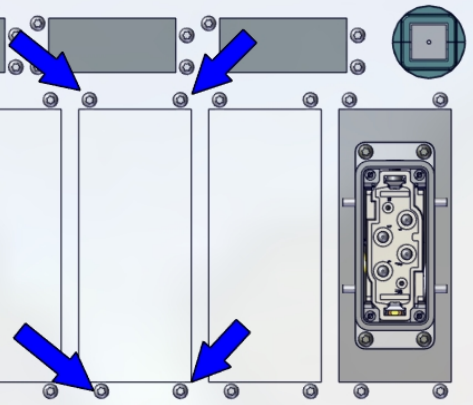
	Action	Note/Illustration
1	Remove the attachment screws.	 xx2100001282
2	Take out the cover from the inside of the controller.	

##### Refitting the cable grommet assembly

##### Refitting the cables to the cable grommet assembly



	Action	Note/Illustration
1	Insert and equip the cable to the corresponding KT grommet.	 xx1900002337

*Continues on next page*

### 3 Installation and commissioning

#### 3.7.7 Installing the cable grommet assembly

*Continued*

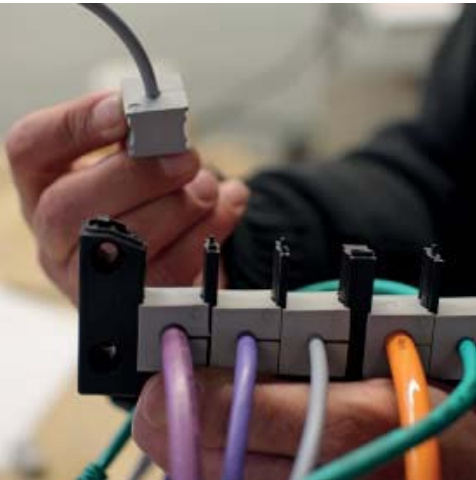
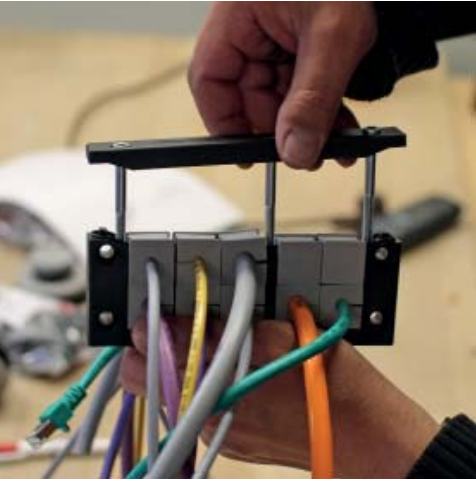
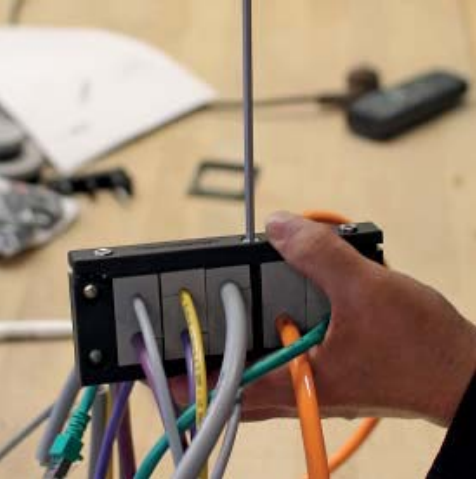

	Action	Note/Illustration
2	<p>Slide the grommets into the frame halves.</p> <p> <b>Note</b></p> <p>It must be ensured that the flat side of the grommets in the lower row are pointing to the open side of the frame half (flat sides pointing upwards).</p> <p> <b>Note</b></p> <p>The flat side of the grommets in the upper row have to point downwards so that all flat sides rest on each other. When using single row frames the flat side has to point towards the cover strip.</p>	 <p>xx1900002336</p>
3	<p>Refit the cover strip onto the frame.</p>	 <p>xx1900002335</p>
4	<p>Secure the frame and cover strip with the screws.</p>	<p>Screws: Hex socket head cap screw M5x50 12.9 Lafre 2C2B/FC6.9 (3 pcs) Tightening torque: 2 Nm - 3 Nm.</p>  <p>xx1900002334</p>

*Continues on next page*

### 3 Installation and commissioning

#### 3.7.7 Installing the cable grommet assembly

Continued

	Action	Note/Illustration
5	Route the cables through the cut-out.	 <p>xx1900002333</p>
6	Refit the cable entry frame to the enclosure wall and secure with the screws.	<p>Screws: Torx pan head screw M4x8 (4 pcs) Tightening torque: 1.5 Nm.</p>  <p>xx1900002332</p>

#### Refitting the cable grommet assembly

	Action	Note/Illustration
1	 <p><b>DANGER</b></p> <p>Before doing any work inside the cabinet, disconnect the mains power. For more information, see <a href="#">Electrical safety on page 29</a>.</p>	

Continues on next page

### 3 Installation and commissioning

#### 3.7.7 Installing the cable grommet assembly

*Continued*

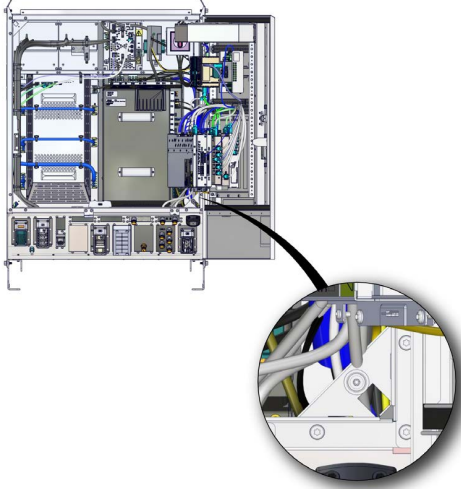
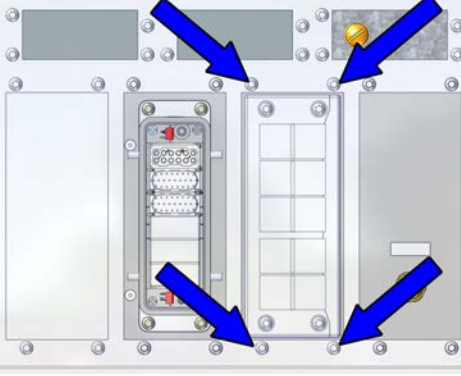
	Action	Note/Illustration
2	<p> <b>ELECTROSTATIC DISCHARGE (ESD)</b></p> <p>The unit is sensitive to ESD. Before handling the unit read the safety information in section <a href="#">The unit is sensitive to ESD on page 45</a>.</p>	<p>Location of wrist strap button:</p>  <p>xx2200001817</p>
3	<p>Insert the cable grommet assembly into the cover of the cabinet. Secure it with the screws.</p>	<p>Screws: Torx pan head screw M4x8 (4 pcs)</p>  <p>xx2100000845</p>

#### Concluding procedure

	Action	Note/Illustration
1	Close the door.	<a href="#">Closing the door on page 189</a> .
2	Perform the function tests to verify that the safety features work properly, see <a href="#">Function tests on page 177</a> .	

### 3 Installation and commissioning

---

#### 3.7.8 Installing the air filter

#### 3.7.8 Installing the air filter

---

##### Location

The illustration shows the location of the air filter on the controller.



xx2200001484

*Continues on next page*

#### Required spare parts



#### Note

The spare part numbers that are listed in the table can be out of date. See the latest spare parts of the OmniCore V250XT Type B via myABB Business Portal, [www.abb.com/myABB](http://www.abb.com/myABB).

Spare part	Article number	Note
Air filter coarse assembly	3HAC082548-001	Option 3005-1 Moist particle filter
Air filter fine assembly	3HAC082547-001	Option 3005-2 Moist dust filter
Air filter, fine (Polymeric)	3HAC084607-001	Option 3005-2 Moist dust filter

#### Required tools and equipment

Equipment	Article number	Note
Standard toolkit	-	Content is defined in section <a href="#">Standard toolkit for controller on page 436</a> .
ESD protective wrist band	-	

#### Required documents

Document	Article number	Note
<i>Circuit diagram - OmniCore V250XT</i> , rev 04 or later	3HAC074000-008	

#### Installing the air filter

	Action	Note/Illustration
1	<p><b>DANGER</b></p> <p>Before doing any work inside the cabinet, disconnect the mains power. For more information, see <a href="#">Electrical safety on page 29</a>.</p>	
2	<p>For option 3005-2 Moist dust filter: Insert the polymeric filter element to the filter and secure with the metallic line.</p>	<p>xx2200001827</p>

Continues on next page

### 3 Installation and commissioning

#### 3.7.8 Installing the air filter

*Continued*

	Action	Note/Illustration
3	Fit the air filter unit to the cabinet.	 <p>The illustration shows a white, rectangular air filter unit with a grid-like front panel. It is positioned to be inserted into a slot on the front of a larger, white industrial cabinet. The cabinet has a control panel at the top and two circular fans at the bottom. A dashed line indicates the alignment of the filter unit with the cabinet's opening. Below the illustration, the reference code 'xx2200001772' is printed.</p> <p>xx2200001772</p>
4	Perform the function tests to verify that the safety features work properly, see <a href="#">Function tests on page 177</a> .	



#### 3.7.9 Installing the mains connections cable

##### Location

The illustration shows the location of the incoming mains cable gland in the controller.

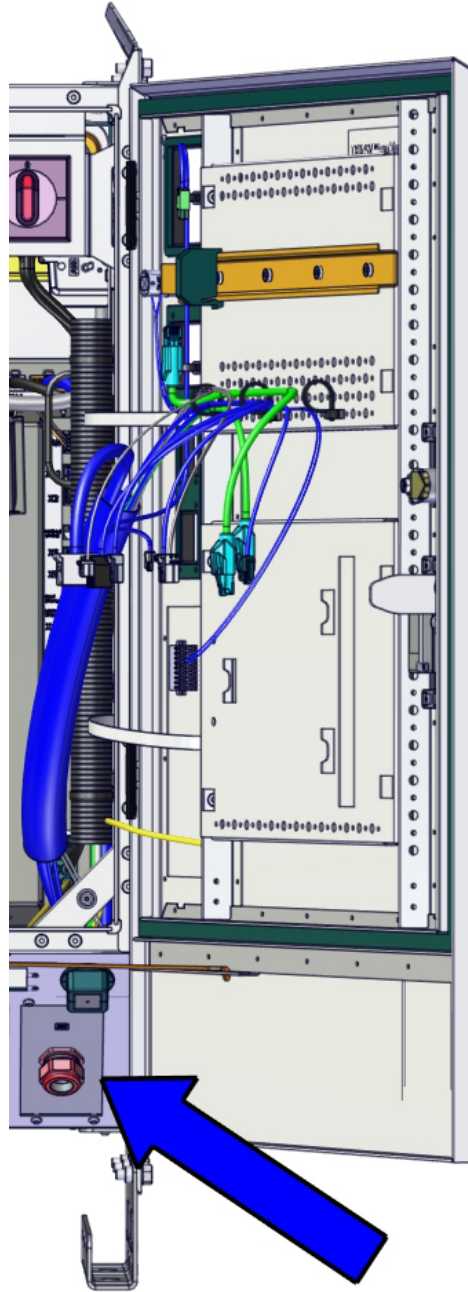

xx2100002285

*Continues on next page*

### 3 Installation and commissioning

---

#### 3.7.9 Installing the mains connections cable

*Continued*

---

#### Required tools and equipment

Equipment	Article number	Note
Standard toolkit	-	Content is defined in section <a href="#">Standard toolkit for controller on page 436</a> .
ESD protective wrist band	-	

---

#### Required documents

Document	Article number	Note
<i>Circuit diagram - OmniCore V250XT</i> , rev 04 or later	3HAC074000-008	

*Continues on next page*

### 3 Installation and commissioning

#### 3.7.9 Installing the mains connections cable

*Continued*

#### Installing the mains connections cable

The following procedures detail how to connect incoming mains to the controller through a cable gland.

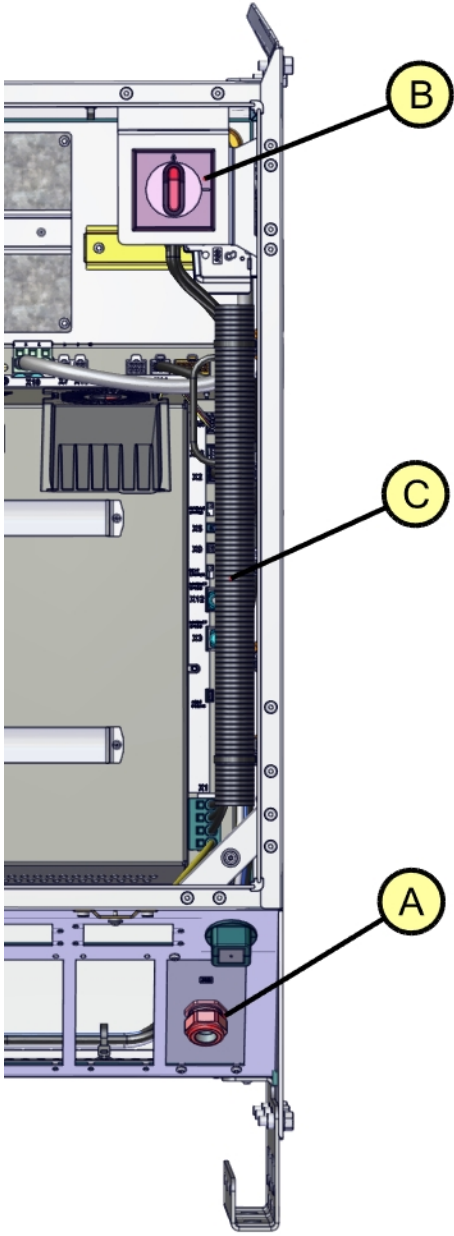
	Action	Note/illustration
1	Remove the dust protection lid from the cable gland (A).	 <p data-bbox="970 1756 1082 1778">xx2100002286</p> <ul data-bbox="1002 1794 1302 1895" style="list-style-type: none"><li>A Cable gland</li><li>B Incoming mains switch</li><li>C Cable pipe</li></ul>
2	Remove protection from the incoming mains switch (B).	

*Continues on next page*

### 3 Installation and commissioning

#### 3.7.9 Installing the mains connections cable

Continued

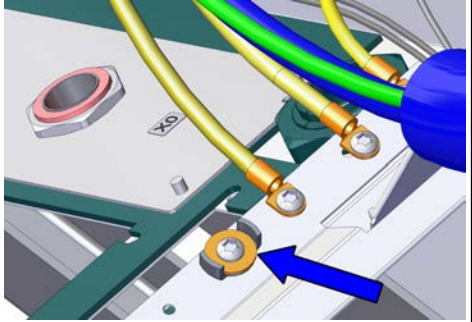
	Action	Note/illustration
3	Connect incoming mains from an external earth fault protection.	<i>Connecting incoming mains and protective earth to the controller on page 84.</i>
4	Fit the cable trough the cable gland (A) and tighten.	
5	Strip the insulation on the mains cable long enough to reach the incoming mains switch (B).	
6	Connect protective earth to one of the two screws.	 <p>xx2100002287</p> <p><b>Note</b> Use cable lugs in the connection. Tightening torque: 5 Nm</p>
7	Route the phase wires through the pipe up to the incoming mains switch (B).	
8	Connect the wires to the incoming mains switch (B).	See circuit diagram.
9	Refit protection on the incoming mains switch (B).	

### 3.7.10 Installing the DeviceNet board

#### Location

The illustration shows the location of the DeviceNet board DSQC1096 in the main computer.

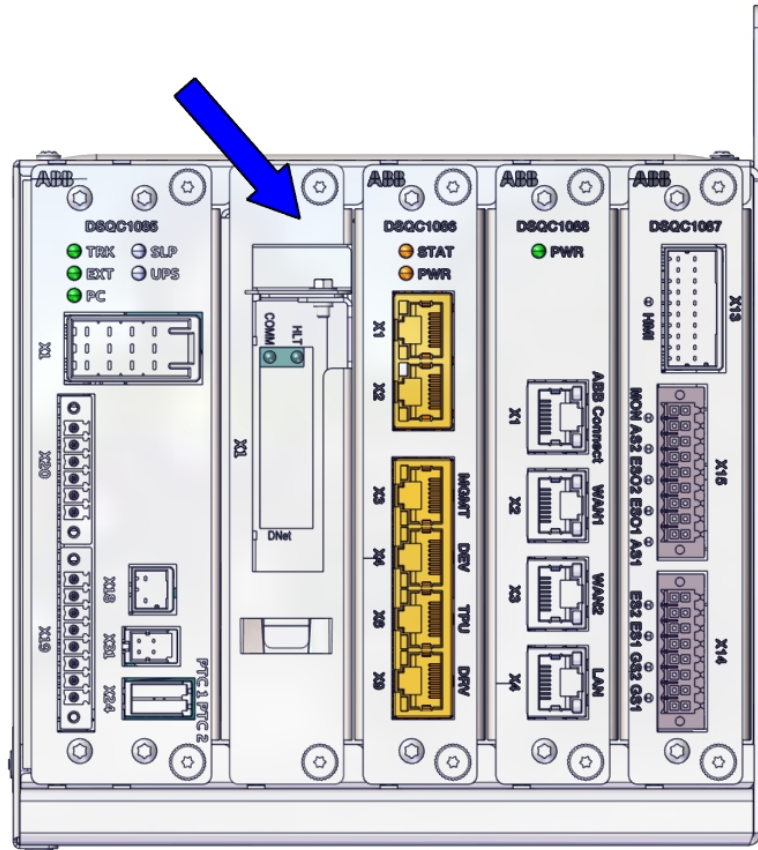

xx2300001738

#### Required spare parts



#### Note

The spare part numbers that are listed in the table can be out of date. See the latest spare parts of the OmniCore V250XT Type B via myABB Business Portal, [www.abb.com/myABB](http://www.abb.com/myABB).

Spare part	Article number	Note
DeviceNet M/S [3029-1]	3HAC085254-001	DSQC1096

#### Required tools and equipment

Equipment	Article number	Note
Standard toolkit	-	Content is defined in section <a href="#">Standard toolkit for controller on page 436</a> .

Continues on next page

### 3 Installation and commissioning

#### 3.7.10 Installing the DeviceNet board

Continued



Equipment	Article number	Note
ESD protective wrist band	-	

#### Required documents

Document	Article number	Note
Circuit diagram - OmniCore V250XT, rev 04 or later	3HAC074000-008	

#### Installing the DeviceNet board

##### Preparations

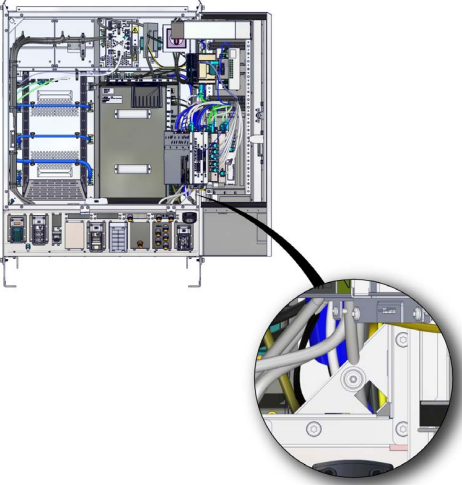
	Action	Note/Illustration
1	 <b>DANGER</b> Before doing any work inside the cabinet, disconnect the mains power. For more information, see <a href="#">Electrical safety on page 29</a> .	
2	Open the door.	<a href="#">Opening the door on page 188</a> .
3	 <b>ELECTROSTATIC DISCHARGE (ESD)</b> The unit is sensitive to ESD. Before handling the unit read the safety information in section <a href="#">The unit is sensitive to ESD on page 45</a> .	Location of wrist strap button:  xx2200001817

#### Installing the DeviceNet board

	Action	Note/Illustration
1	Loosen the screws that hold the cover plate.	
2	Remove the cover plate from the main computer assembly.	
3	Insert the DeviceNet board into the slot in the main computer assembly.	

Continues on next page

### 3 Installation and commissioning

#### 3.7.10 Installing the DeviceNet board

*Continued*

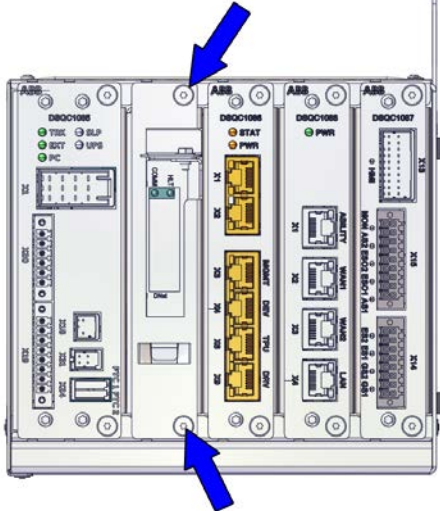
	Action	Note/Illustration
4	Secure the screws that hold the DeviceNet board unit.	 <p>xx2300000921</p>

#### Concluding procedure

	Action	Note/Illustration
1	Close the door.	<a href="#">Closing the door on page 189.</a>
2	Perform the function tests to verify that the safety features work properly, see <a href="#">Function tests on page 177.</a>	

## 3 Installation and commissioning

### 3.7.11 Installing the motor connection box

#### 3.7.11 Installing the motor connection box

##### Location

The motor connection box location is decided by the customer.

##### Required spare parts



##### Note

The spare part numbers that are listed in the table can be out of date. See the latest spare parts of the OmniCore V250XT Type B via myABB Business Portal, [www.abb.com/myABB](http://www.abb.com/myABB).

Spare part	Article number	Note
Motor Connection Box	3HAC087717-001	3-axis
Motor Connection Box	3HAC087718-001	3-axis, BRB
Motor Connection Box	3HAC087719-001	6-axis
Motor Connection Box	3HAC087720-001	6-axis, BRB

##### Required tools and equipment

Equipment	Article number	Note
Standard toolkit	-	Content is defined in section <a href="#">Standard toolkit for controller on page 436</a> .
ESD protective wrist band	-	



##### Note

It is the responsibility of the integrator to install a quenching circuit when connecting third party motors.

##### Required documents

Document	Article number	Note
<i>Circuit diagram - OmniCore V250XT</i> , rev 04 or later	3HAC074000-008	

##### Installing the motor connection box

	Action	Note/Illustration
1	 <b>DANGER</b> Before doing any work inside the cabinet, disconnect the mains power. For more information, see <a href="#">Electrical safety on page 29</a> .	

Continues on next page



### 3 Installation and commissioning

#### 3.7.11 Installing the motor connection box

*Continued*

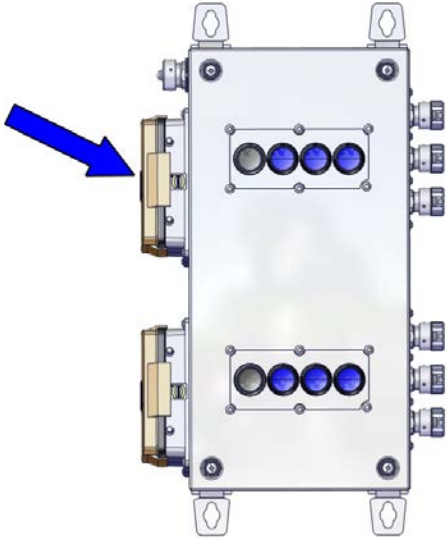
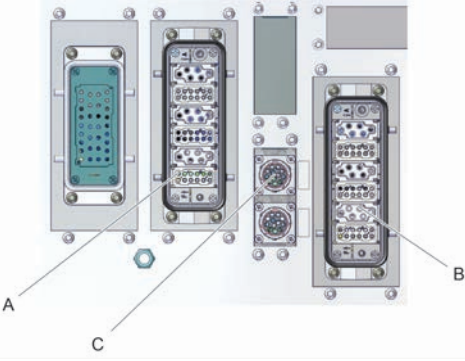
	Action	Note/Illustration
2	Fit the motor connection box in its location. Secure with screws.	 <b>Note</b> Due to the stiffness of the floor cables, the minimum required space beside the motor connection box is 330 on the left side and 180 on the right side.
3	If third party motors are to be connected, install a quenching circuit.	
4	Connect the motor cable to the motor connection box.	 <p>xx2300001746</p>
5	Connect the cables from the motor connection box to the connectors for ADU 1-3 (A) and ADU 4-6 (B) on the cabinet.	 <p>xx2300001919</p>
6	Connect the SMB cable to the SMB connector for ADU 1-6 (C) on the cabinet.	

*Continues on next page*

### 3 Installation and commissioning

#### 3.7.11 Installing the motor connection box

Continued

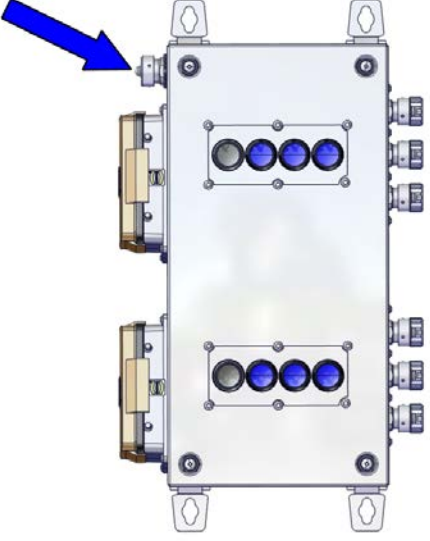
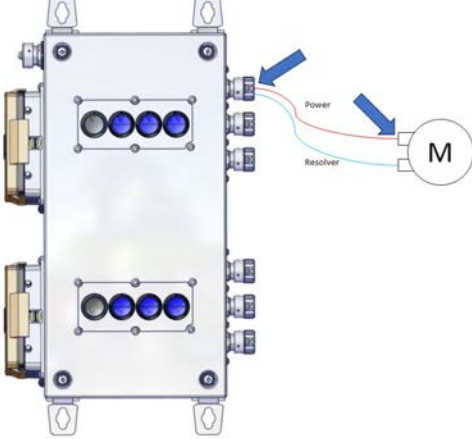
Action	Note/Illustration
7	<p>Connect the SMB cable to the motor connection box.</p>  <p>xx2300001747</p>
8	<p>Connect motor cables and resolver cables to the auxiliary equipment motor.</p>
9	<p>Connect motor cables and resolver cables to the motor connection box.</p>  <p>xx2300001850</p>
10	<p>Perform the function tests to verify that the safety features work properly, see <a href="#">Function tests on page 177</a>.</p>

### 3.7.12 Installing the process cable gland process interface

#### Overview

The process cable gland process interface is used for connection of external process equipment.

#### Required spare parts



#### Note

The spare part numbers that are listed in the table can be out of date. See the latest spare parts of the OmniCore V250XT Type B via myABB Business Portal, [www.abb.com/myABB](http://www.abb.com/myABB).

Spare part	Article number	Note
Cable gland process interface	3HAC079449-001	

#### Required tools and equipment

Equipment	Article number	Note
Standard toolkit	-	Content is defined in section <a href="#">Standard toolkit for controller on page 436</a> .
ESD protective wrist band	-	

#### Required documents

Document	Article number	Note
<i>Circuit diagram - OmniCore V250XT</i> , rev 04 or later	3HAC074000-008	

#### Installing the process cable gland process interface

	Action	Note/Illustration
1	<p><b>DANGER</b></p> <p>Before doing any work inside the cabinet, disconnect the mains power. For more information, see <a href="#">Electrical safety on page 29</a>.</p>	
2	Open the door.	<a href="#">Opening the door on page 188</a> .

Continues on next page

### 3 Installation and commissioning

#### 3.7.12 Installing the process cable gland process interface

*Continued*

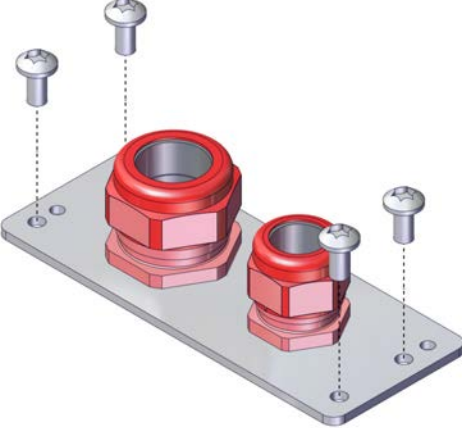
	Action	Note/Illustration
3	Insert the process cable gland process interface into the front panel from inner side of the cabinet and fasten it with the screws.	<p data-bbox="927 315 1398 376">Screws: Torx pan head screw M4x8 (4 pcs) Tightening torque: 2.8 Nm.</p>  <p data-bbox="927 842 1031 860">xx240000178</p>
4	Close the door.	<a href="#">Closing the door on page 189.</a>
5	Perform the function tests to verify that the safety features work properly, see <a href="#">Function tests on page 177.</a>	

### 3.7.13 Installing the CP/CS harness

#### Location

The CP/CS harness is located in the fixed installation panel in the controller.

#### Required spare parts



#### Note

The spare part numbers that are listed in the table can be out of date. See the latest spare parts of the OmniCore V250XT Type B via myABB Business Portal, [www.abb.com/myABB](http://www.abb.com/myABB).

Spare part	Article number	Note
Harness CPCS	3HAC084143-001	[3055-1] (option)
Harness CPCS	3HAC089798-001	[3055-2] (option)

#### Required tools and equipment

Equipment	Article number	Note
Standard toolkit	-	Content is defined in section <a href="#">Standard toolkit for controller on page 436</a> .
ESD protective wrist band	-	

#### Required documents

Document	Article number	Note
<i>Circuit diagram - OmniCore V250XT</i> , rev 04 or later	3HAC074000-008	

#### Installing the CP/CS harness

	Action	Note/Illustration
1	<p><b>DANGER</b></p> <p>Before doing any work inside the cabinet, disconnect the mains power. For more information, see <a href="#">Electrical safety on page 29</a>.</p>	
2	Open the door.	<a href="#">Opening the door on page 188</a> .

*Continues on next page*

### 3 Installation and commissioning

#### 3.7.13 Installing the CP/CS harness

Continued

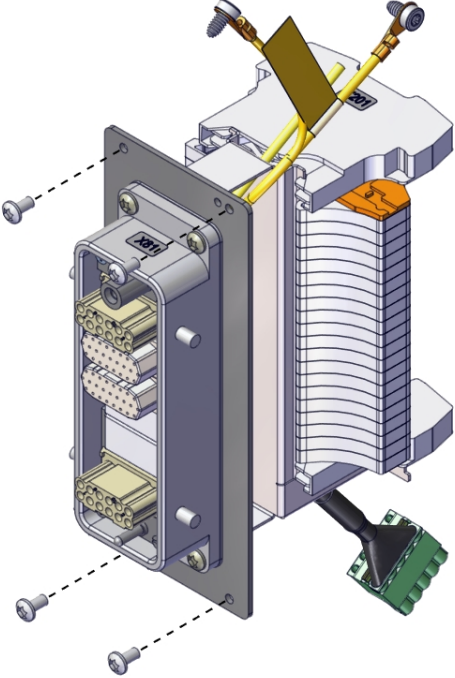
Action	Note/Illustration	
3	Insert the CP/CS harness into the front panel from inner side of the cabinet and fasten it with the screws.	Screws: Torx pan head screw M4x8 (4 pcs) Tightening torque: 2.8 Nm.
	 <p data-bbox="922 1099 1031 1122">xx2400000268</p>	
4	If applicable, connect the harness to the main computer. <ul style="list-style-type: none"> <li>• X81 - A2.K2.X1</li> </ul>	Route the harness from the fixed installation panel to the unit on the door.
5	Connect to protective earth.	Tightening torque: 5 Nm
6	Close the door.	<a href="#">Closing the door on page 189.</a>
7	Perform the function tests to verify that the safety features work properly, see <a href="#">Function tests on page 177.</a>	

### 3.8 Installing external devices

#### General



#### **WARNING**

Only electrical equipment operating within a rated voltage range of 0 to 24 V DC is allowed on the door of the controller.

Available current supplied to or from this equipment must not exceed 8 A under any condition of load, including short circuit.

## 3 Installation and commissioning

---

### 3.9 Initial test before commissioning

### 3.9 Initial test before commissioning

---

#### Protective earth

Before supplying power to the robot and commissioning, verify that the cabinet is connected to protective earth according to [Connecting incoming mains and protective earth to the controller on page 84](#).

---

#### Function tests

Before commissioning, perform the function tests in section [Function tests on page 177](#) to verify that the safety features work properly.



## 4 Maintenance

### 4.1 Maintenance schedule for the OmniCore controller

#### General

The controller must be maintained at regular intervals to ensure its function. The activities and intervals are described in this section.

#### Activities and intervals

Equipment	Maintenance activity	Interval	Detailed in section:
Complete controller	Inspection	12 months <sup>i</sup>	<a href="#">Inspecting the OmniCore V250XT Type B controller on page 166</a>
Air filter	Cleaning		<a href="#">Cleaning air filter on page 167</a>
Air filter	Replacement	24 months	<a href="#">Replacement of air filter on page 173</a>
System fans	Inspection	6 months <sup>i</sup>	<a href="#">Inspecting the OmniCore V250XT Type B controller on page 166</a>
Control cabinet	Cleaning		<a href="#">Cleaning of the controller cabinet on page 170</a>
FlexPendant	Cleaning	When needed	<a href="#">Cleaning the FlexPendant on page 171</a>
Emergency stop (FlexPendant)	Function test	12 months	<a href="#">Function test of emergency stop on page 177</a>
Manual, auto and manual full speed mode with FlexPendant	Function test	12 months	<a href="#">Function test of manual, auto, and manual full speed mode with FlexPendant on page 178</a>
Enabling device	Function test	12 months	<a href="#">Function test of three-position enabling device on page 179</a>
Auto stop (tested if used)	Function test	12 months	<a href="#">Function test of Automatic Stop on page 181</a>
General stop (tested if used)	Function test	12 months	<a href="#">Function test of General Stop on page 182</a>
External emergency stop (tested if used)	Function test	12 months	<a href="#">Function test of external emergency stop on page 183</a>
ESTOP_STATUS output (tested if used)	Function test	12 months	<a href="#">Function test of ESTOP_STATUS output on page 184</a>
Reduced speed control	Function test	During commissioning	<a href="#">Function test of reduced speed control on page 185.</a>

<sup>i</sup> The interval depends on the working environment of the equipment: a cleaner environment may extend the maintenance interval and vice versa.

#### Function test after replacement of component

After replacing a component in the controller, the function tests should be performed. See [Function tests on page 177](#).



## 4 Maintenance

### 4.2.1 Inspection of controller

## 4.2 Inspection activities

### 4.2.1 Inspection of controller

#### Inspecting the OmniCore V250XT Type B controller

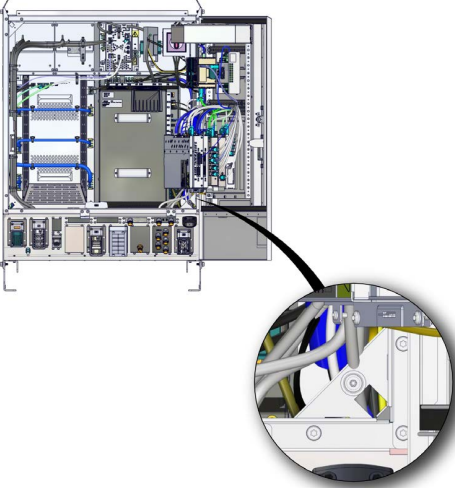
	Action	Note/illustration
1	 <b>DANGER</b> Before doing any work inside the cabinet, disconnect the mains power. For more information, see <a href="#">Electrical safety on page 29</a> .	
2	 <b>ELECTROSTATIC DISCHARGE (ESD)</b> The unit is sensitive to ESD. Before handling the unit read the safety information in section <a href="#">The unit is sensitive to ESD on page 45</a> .	Location of wrist strap button:  xx2200001817
3	Inspect connectors and cabling to make sure they are securely fastened and cabling not damaged.	
4	Inspect the fans and ventilation holes to make sure they are clean.	
5	After inspection: Temporarily turn the power supply on. Inspect the fans to make sure they function correctly. Switch the power off.	

## 4.3 Cleaning activities

### 4.3.1 Cleaning air filter

#### Location

The air filter is located as shown in the illustration below.



xx2200001484

*Continues on next page*

## 4 Maintenance

### 4.3.1 Cleaning air filter



*Continued*

#### Required equipment

Equipment	Note
Cleaning agent	Water 30-40 °C with cleansing liquid or detergent.
Compressed air	

#### Cleaning the fine filter (polymeric filter)

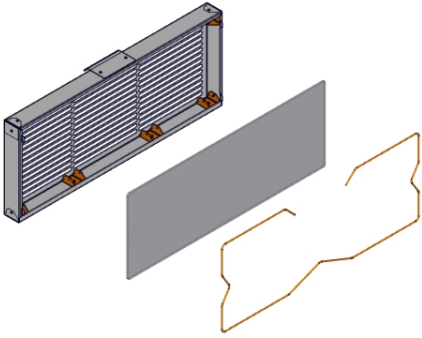
The procedure below details how to clean the fine filter, that is option *3005-2 Moist dust filter*.

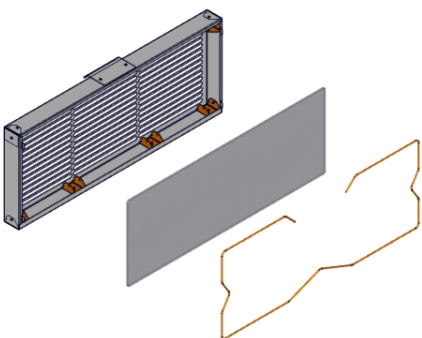
	Action	Note/Illustration
1	Remove the air filter unit.	
2	Remove the polymeric filter element.	 <p>xx2200001827</p>
3	Clean the filter three or four times.	
4	Allow the filter to dry in one of these ways: <ul style="list-style-type: none"> <li>• Lying flat on a flat surface</li> <li>• Blow with compressed air in opposite direction of filter airflow.</li> </ul>	 <b>Note</b> Do not wring the filter to press out water.
5	Insert the polymeric filter element to the filter and secure with the metallic line.	 <p>xx2200001827</p>
6	Refit the air filter unit to the cabinet.	

*Continues on next page*

**Cleaning the coarse filter (metal mesh)**

The procedure below details how to clean the coarse filter, that is option *3005-1 Moist particle filter*.



**Note**

The coarse filter cannot be separated from the filter assembly.

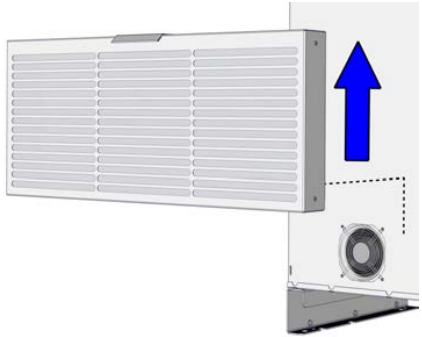
	Action	Note/Illustration
1	Remove the air filter unit.	 <p>xx2200001773</p>
2	Clean the metal mesh filter with compressed air.	
3	Refit the air filter unit to the cabinet.	

## 4 Maintenance

---

### 4.3.2 Cleaning of the controller cabinet

### 4.3.2 Cleaning of the controller cabinet

---

#### Required equipment

Equipment, etc.	Note
Vacuum cleaner	ESD protected

---

#### Cleaning considerations

This section specifies some special considerations when cleaning the controller.

- Always use ESD protection.
- Always use cleaning equipment as specified above. Any other cleaning equipment may shorten the life of paint work, rust inhibitors, signs, or labels.
- Always make sure that all protective covers are fitted to the controller before cleaning.
- Never remove any covers or other protective devices when cleaning the outside of the controller.
- Never use compressed air or spray with a high pressure cleaner.
- Never leave the door open when cleaning the exterior.

### 4.3.3 Cleaning the FlexPendant

#### Location

The surfaces to clean are shown in the illustration below.

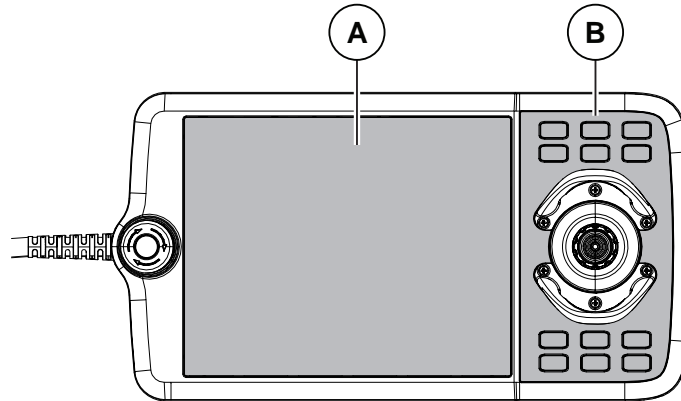

xx180000128

A	Touch screen
B	Hard buttons

#### Required equipment

Equipment, etc.	Note
Soft cloth	ESD protected
Water/Mild cleaning agent	

#### Clean the touch screen

This section describes how to clean the touch screen.

	Action	Info/Illustration
1	Lock the screen.	
2	It is safe to clean the FlexPendant when the Lock screen appears.	
3	Clean the touch screen and hardware buttons using a soft cloth and water or a mild cleaning agent.	
4	Unlock the screen, by tapping the buttons.	

#### Cleaning considerations

The section below specifies some special considerations when cleaning the FlexPendant:

- Use ESD Protection
- Use cleaning equipment as specified above. Any other cleaning equipment may shorten the life time of the touch screen.
- Check that all protective covers are fitted to the device before cleaning.
- Make sure that no foreign objects or liquids can penetrate into the device.

*Continues on next page*

## 4 Maintenance

---

### 4.3.3 Cleaning the FlexPendant

*Continued*

- Do not remove any covers before cleaning the FlexPendant.
- Do not spray with a high pressure cleaner.
- Do not clean the device, operating panel and operating elements with compressed air, solvents, scouring agent or scrubbing sponges.



## 4.4 Changing/replacing activities

### 4.4.1 Replacement of air filter

#### Location

The air filter unit is located as shown in the illustration below.



xx2200001484

*Continues on next page*

## 4 Maintenance

### 4.4.1 Replacement of air filter

*Continued*

#### Required equipment

Equipment	Note
Air filter	
Other tools and procedures may be required. See references to these procedures in the step-by-step instructions below.	These procedures include references to the tools required.

#### Removing the air filter

##### Preparations

	Action	Note/Illustration
1	 <b>DANGER</b> Before doing any work inside the cabinet, disconnect the mains power. For more information, see <a href="#">Electrical safety on page 29</a> .	

#### Removing the air filter

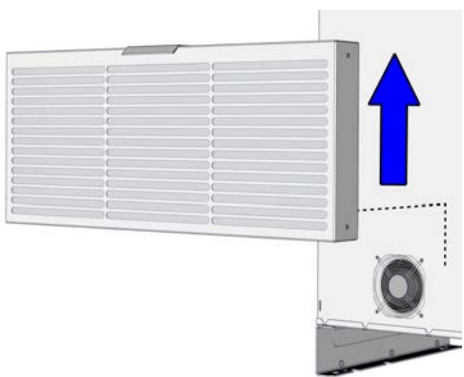
	Action	Note/Illustration
1	Remove the air filter unit.	 xx2200001773

*Continues on next page*

#### Removing the polymeric filter element

The procedure below details how to remove the polymeric filter element (option *3005-2 Moist dust filter*).

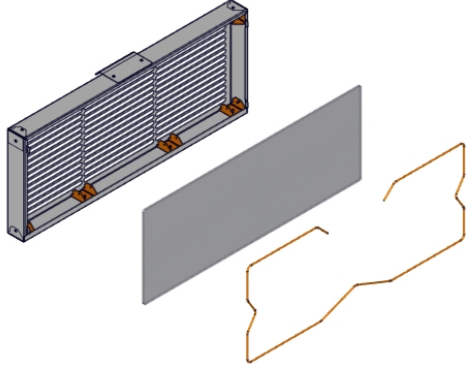
	Action	Note/Illustration
1	Take out the polymeric filter element from the filter.	 <p>xx2200001827</p>

#### Refitting the air filter

##### Refitting the polymeric filter element

The procedure below details how to refit the polymeric filter element (option *3005-2 Moist dust filter*).

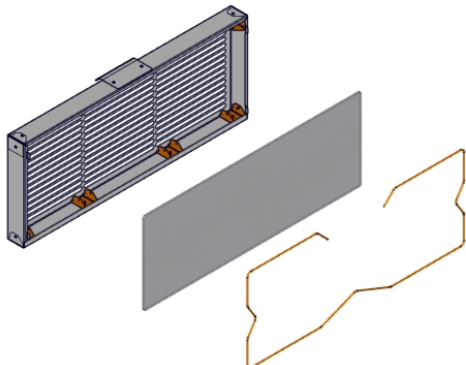
	Action	Note/Illustration
1	Insert the polymeric filter element to the filter and secure with the metallic line.	 <p>xx2200001827</p>

#### Refitting the air filter

	Action	Note/Illustration
1	 <p><b>DANGER</b></p> <p>Before doing any work inside the cabinet, disconnect the mains power. For more information, see <a href="#">Electrical safety on page 29</a>.</p>	
2	Refit the air filter unit to the cabinet.	

*Continues on next page*

## 4 Maintenance

---

### 4.4.1 Replacement of air filter

*Continued*

Concluding procedure

	Action	Note/Illustration
1	Perform the function tests to verify that the safety features work properly, see <a href="#">Function tests on page 177</a> .	

## 4.5 Function tests

### 4.5.1 Function test of emergency stop

#### Overview

Validate the function of the FlexPendant emergency stop device.



#### Note

Also perform the test for any additional emergency stop devices.

#### Performing the function test

	Action	Note
1	Make a visual inspection of the emergency stop device to make sure it is not physically damaged.	If any damage is found on the emergency stop device, it must be replaced.
2	Pull and rotate the emergency stop device clockwise to verify that it is not pressed in.	
3	Power on the robot.	
4	Press the emergency stop device on the FlexPendant.  <b>Note</b> If the event message <b>20223 Emergency stop conflict</b> appears in the event log, or the event message <b>10013 Emergency stop state</b> (and <b>90518 Safety controller Emergency stop triggered</b> for robots prepared for collaborative applications) does not appear, then the test has failed and the root cause of the failure must be found.	The test is passed if the event message <b>10013 Emergency stop state</b> appears in the event log. If either of the following happens, then the test is failed and the root cause must be found: <ul style="list-style-type: none"> <li>• if the event message <b>10013 Emergency stop state</b> does not appear</li> <li>• if the event message <b>90780 Two-channel fault in Safety Controller</b> appears</li> </ul> <b>Note</b> For robots prepared for collaborative applications, the event message <b>90518 Safety controller Emergency stop triggered</b> appears by default. The message <b>10013 Emergency stop state</b> is also available in the event log.
5	Release the emergency stop device to reset the emergency stop state.	

## 4 Maintenance

### 4.5.2 Function test of manual, auto, and manual full speed mode with FlexPendant

### 4.5.2 Function test of manual, auto, and manual full speed mode with FlexPendant

#### Overview

Perform this function test to change the mode on the FlexPendant using the following operation:

- **Status bar > Common Settings > Operating Mode (Auto/Manual/Man FS).**

For more detailed information, see *Operating manual - OmniCore, 3HAC065036-001*.

#### Performing the function test

	Action	Note
1	Start the robot system.	
2	Change to <b>Automatic</b> operating mode and <b>Motors ON</b> state, and then run the robot in auto mode.	This test is passed if it is possible to run the robot program in auto mode. If it is not possible to run the robot program, this test is failed and the root cause of the failure must be found.
3	Change to <b>Manual</b> operating mode and <b>Motors ON</b> state, and then run the robot in manual mode.	This test is passed if it is possible to run the robot program in manual mode. If it is not possible to run the robot program, this test is failed and the root cause of the failure must be found.
4	Change to <b>Manual Full Speed</b> mode and <b>Motors ON</b> state, and then run the robot in manual full speed mode.   <b>Note</b> Manual full speed mode is not available in USA or Canada.	This test is passed if it is possible to run the robot program in manual full speed mode. If it is not possible to run the robot program, this test is failed and the root cause of the failure must be found.

### 4.5.3 Function test of three-position enabling device

#### Performing the function test

	Action	Note
1	Start the robot system and turn the mode switch to manual mode.	
2	Press the three-position enabling device to the middle position and then hold the enabling device in this position.	<p>This test is passed if the event message <b>10011 Motors ON state</b> appears in the event log.</p> <p>If either of the following happens, then the test is failed and the root cause must be found:</p> <ul style="list-style-type: none"> <li>• if the event message <b>10011 Motors ON state</b> does not appear</li> <li>• if the event message <b>90780 Two-channel fault in Safety Controller</b> appears</li> </ul>
3	While still holding the three-position enabling device pressed, press the enabling device harder to enable the device's third position.	<p>This test is passed if the event message <b>10012 Safety guard stop state</b> appears in the event log.</p> <p>If either of the following happens, then the test is failed and the root cause must be found:</p> <ul style="list-style-type: none"> <li>• if the event message <b>10012 Safety guard stop state</b> does not appear</li> <li>• if the event message <b>90780 Two-channel fault in Safety Controller</b> appears</li> </ul>

## 4 Maintenance

### 4.5.4 Function test of safety switches

#### 4.5.4 Function test of safety switches

##### Performing the motor function test

	Action	Note
1	Start the robot system and change the operating mode to manual.	
2	Press the three-position enabling device to the middle position and then hold the enabling device in this position.	This test is passed if the event message <b>10011 Motors ON state</b> appears in the event log. If the event message <b>37001 Motor on activation error</b> appears in the event log, then the test has failed and the root cause of the failure must be found.
3	Release the three-position enabling device.	This test is passed if the event message <b>10012 Safety guard stop state</b> appears in the event log. If the event message <b>90227 Motor contact or conflict</b> appears in the event log, then the test has failed and the root cause of the failure must be found.

##### Performing the brake function test

	Action	Note
1	Start the robot system and change the operating mode to manual.	
2	Press the three-position enabling device to the middle position and then hold the enabling device in this position. While having eye contact with the manipulator, move the joystick slightly in any direction to disengage the brakes.	This test is passed if the brakes are disengaged and the manipulator can be moved. If the event message <b>50056 Joint collision</b> appears in the event log, then the test has failed and the root cause of the failure must be found.
3	Release the three-position enabling device to engage the brakes.	This test is passed if the event message <b>10012 Safety guard stop state</b> appears in the event log. If the event message <b>37101 Brake Failure</b> appears in the event log, then the test has failed and the root cause of the failure must be found.



## 4.5.5 Function test of Automatic Stop

### Performing the function test

	Action	Note
1	Start the robot system and change the operating mode to auto mode.	
2	Activate the Automatic Stop, for example by opening the connected robot cell door, which has interlock connection with Automatic Stop.	<p>The test is passed if the event message <b>90523 Safety Controller Protective Stop triggered</b> appears in the event log.</p> <p>If either of the following happens, then the test is failed and the root cause must be found:</p> <ul style="list-style-type: none"><li>• if the event message <b>90523 Safety Controller Protective Stop triggered</b> does not appear</li><li>• if the event message <b>90780 Two-channel fault in Safety Controller</b> appears</li></ul>

## 4 Maintenance

---

### 4.5.6 Function test of General Stop

### 4.5.6 Function test of General Stop

---

#### Performing the function test



	Action	Note
1	Start the robot system.	
2	Activate the General Stop.	<p>The test is passed if the event message <b>90523 Safety Controller Protective Stop triggered</b> appears in the event log.</p> <p>If either of the following happens, then the test is failed and the root cause must be found:</p> <ul style="list-style-type: none"><li>• if the event message <b>90523 Safety Controller Protective Stop triggered</b> does not appear</li><li>• if the event message <b>90780 Two-channel fault in Safety Controller</b> appears</li></ul>

## 4.5.7 Function test of external emergency stop

### Overview

Perform this test on the external emergency stop device.

### Performing the function test

	Action	Note
1	Make a visual inspection of the external emergency stop device and the connection harness to make sure they are not physically damaged.	If any damage is found on the external emergency stop device or the connection harness, it must be replaced.
2	<p>Pull and rotate the button on the external emergency stop device clockwise to verify that it is not pressed in.</p> <p> <b>Note</b></p> <p>If the external emergency stop device is not controlled by a push-button, make sure to verify that it is not activated.</p>	
3	Start the robot system.	
4	Press the emergency stop device.	<p>The test is passed if the event message <b>10013 Emergency stop state</b> appears in the event log.</p> <p>If the event message <b>90780 Two-channel fault in Safety Controller</b> appears in the event log, or the event message <b>10013 Emergency stop state</b> does not appear, then the test has failed and the root cause of the failure must be found.</p> <p> <b>Note</b></p> <p>The event message <b>90518 Safety controller Emergency stop triggered</b> appears by default.</p>
5	Release the external emergency stop device to reset the external emergency stop state.	

## 4 Maintenance



### 4.5.8 Function test of ESTOP\_STATUS output

### 4.5.8 Function test of ESTOP\_STATUS output

#### Overview

Perform this test on the FlexPendant emergency stop device or the external emergency stop device, with the accessory device.

#### Performing the function test

	Action	Note
1	Make a visual inspection of the emergency stop device, external emergency stop device, accessory device and the connection harness to make sure they are not physically damaged.	If any damage is found, it must be replaced.
2	Pull and rotate the emergency stop device clockwise to verify that it is not pressed in.  <b>Note</b> If the external emergency stop device is not controlled by a push-button, make sure to verify that it is not activated.	
3	Start the robot system.	
4	Press the emergency stop device.	The test is passed if the event message <b>10013 Emergency stop state</b> appears in the event log. If the event message <b>90780 Two-channel fault in Safety Controller</b> appears in the event log, or the event message <b>10013 Emergency stop state</b> does not appear, then the test has failed and the root cause of the failure must be found.  <b>Note</b> The event message <b>90518 Safety controller Emergency stop triggered</b> appears by default.
5	Make sure that the accessory device is in emergency stop status.	
6	Release the emergency stop device or the external emergency stop device to reset the emergency stop state.	
7	Make sure that the accessory device is not in emergency stop status any more and can be reset.	

## 4.5.9 Function test of reduced speed control

### Performing the function test

	Action	Note
1	Start the robot system and change the operating mode to manual.	
2	Create a test program where the robot moves along a known distance with a programmed speed higher than 250 mm/s.	The distance and speed must be adapted to the current installation and robot model.
3	<p>Start the program in manual mode and measure the time it takes for the robot to travel the distance.</p> <p> <b>Tip</b></p> <p>To get accurate results, use sensors or I/O signals to measure the time.</p>	This test is passed if the speed of the robot does not exceed 250 mm/s, otherwise the test is failed and the root cause of the failure must be found.

**This page is intentionally left blank**

## 5 Repair

### 5.1 Introduction to repair

#### Structure of this chapter

This chapter describes all repair activities recommended for the OmniCore V250XT Type B and any external unit.

It is made up of separate procedures, each describing a specific repair activity. Each procedure contains all the information required to perform the activity, for example spare parts numbers, required special tools, and materials.

All procedures assume that the controller is easy to access from all sides and that no additional covers or equipment are fitted.



#### WARNING

Repair activities not described in this chapter must only be carried out by ABB. Otherwise damage to the mechanics and electronics may occur.

#### Required equipment

The details of the equipment required to perform a specific repair activity are listed in the respective procedures.

#### Safety information

Read chapter [Safety on page 13](#) before commencing any service work.



#### WARNING

Wait at least three minutes after powering off the controller before opening it and at least fifteen minutes until all LED indicators are off before replacing modules. Allow the surfaces to cool down before maintenance or repair.



#### CAUTION

During maintenance inside the controller, beware of sharp corners on the internal fan located on the door.



#### Note

When replacing a part on the OmniCore V250XT Type B, report to your local ABB the serial number, the article number, and the revision of both the replaced unit and the replacement unit.

This is particularly important for safety equipment to maintain the safety integrity of the installation.

## 5 Repair

### 5.2.1 Opening the robot controller

## 5.2 Replacement of controller parts

### 5.2.1 Opening the robot controller

#### Required tools and equipment

Equipment	Article number	Note
Standard toolkit	-	Content is defined in section <a href="#">Standard toolkit for controller on page 436</a> .
ESD protective wrist band	-	

#### Required documents

Document	Article number	Note
<i>Circuit diagram - OmniCore V250XT, rev 04 or later</i>	3HAC074000-008	

#### Opening the door

##### Preparations

	Action	Info/illustration
1	 <b>DANGER</b> Before doing any work inside the cabinet, disconnect the mains power. For more information, see <a href="#">Electrical safety on page 29</a> .	

##### Opening the door

	Action	Info/illustration
1	Insert the key to the door and turn it anti-clockwise.	
2	Pull out the handle and turn it anti-clockwise.	
3	Pull out the door with the handle.	
4	 <b>Tip</b> Use the door stop to lock the door position before maintenance is started.	

*Continues on next page*





Closing the door

Closing the door

	Action	Info/illustration
1	If door stop has been used during maintenance, place the door stop in its original position.	
2	Push the door back.	
3	Turn the handle clockwise and push it back into the lock.	
4	Turn the key back and take it out.	

Removing the controller covers

Preparations

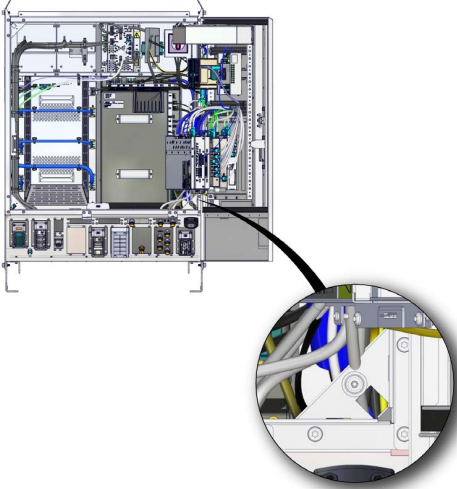
	Action	Info/illustration
1	 <b>DANGER</b> Before doing any work inside the cabinet, disconnect the mains power. For more information, see <a href="#">Electrical safety on page 29</a> .	
2	 <b>ELECTROSTATIC DISCHARGE (ESD)</b> The unit is sensitive to ESD. Before handling the unit read the safety information in section <a href="#">The unit is sensitive to ESD on page 45</a> .	Location of wrist strap button:  xx2200001817

Continues on next page

## 5 Repair

### 5.2.1 Opening the robot controller

*Continued*

#### Removing the rear cover

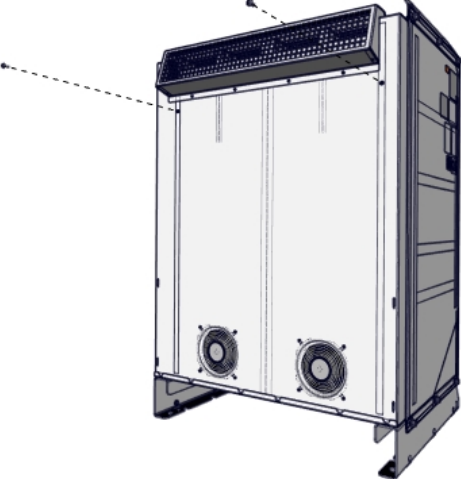
	Action	Info/illustration
1	Lift off the air filter cover plate.	 <p data-bbox="927 752 1031 770">xx2200001773</p>
2	Remove the screws.	 <p data-bbox="927 1319 1031 1337">xx2200001062</p>
3	Remove the rear cover.	

#### Refitting the controller covers

##### Preparations

	Action	Info/illustration
1	 <p data-bbox="563 1630 671 1659"><b>DANGER</b></p> <p data-bbox="472 1688 911 1794">Before doing any work inside the cabinet, disconnect the mains power. For more information, see <a href="#">Electrical safety on page 29</a>.</p>	

*Continues on next page*

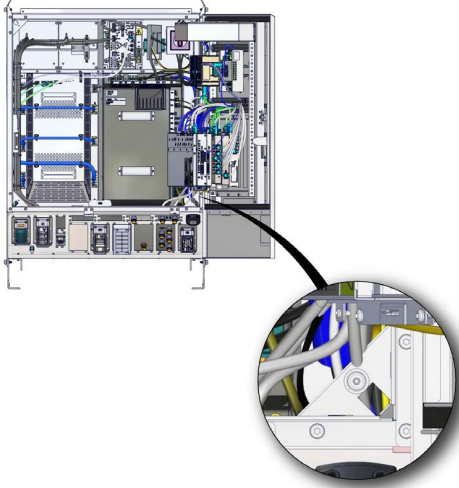
	Action	Info/illustration
2	 <p><b>ELECTROSTATIC DISCHARGE (ESD)</b></p> <p>The unit is sensitive to ESD. Before handling the unit read the safety information in section <i>The unit is sensitive to ESD on page 45.</i></p>	<p>Location of wrist strap button:</p>  <p>xx2200001817</p>

Refitting the rear cover

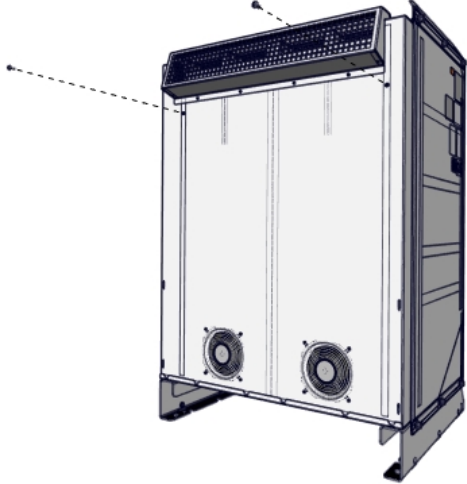
	Action	Info/illustration
1	Refit the the rear cover.	
2	Secure it with the screws.	 <p>xx2200001062</p>

Continues on next page

## 5 Repair

### 5.2.1 Opening the robot controller

*Continued*

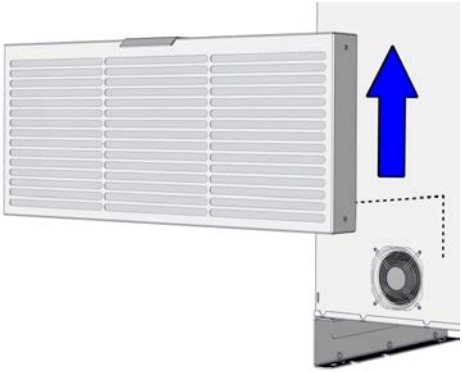
	Action	Info/illustration
3	Refit the air filter cover plate.	 <p data-bbox="924 701 1034 719">xx2200001773</p>

## 5.2.2 Replacing the fans

### Location

The illustration shows the location of the fans in the controller.

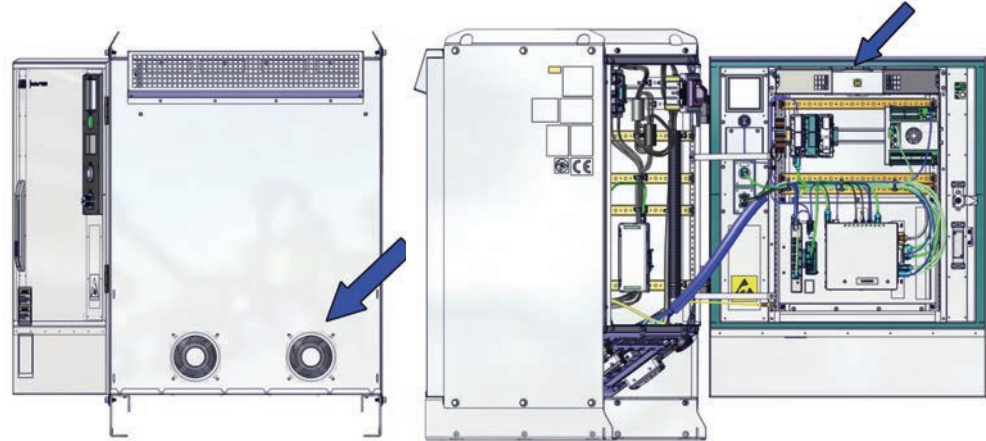

xx240000282

### Required spare parts



#### Note

The spare part numbers that are listed in the table can be out of date. See the latest spare parts of the OmniCore V250XT Type B via myABB Business Portal, [www.abb.com/myABB](http://www.abb.com/myABB).

Spare part	Article number	Note
Fan unit	3HAC082805-001	External fan
Fan unit	3HAC083027-001	Internal fan

### Required tools and equipment

Equipment	Article number	Note
Standard toolkit	-	Content is defined in section <a href="#">Standard toolkit for controller on page 436</a> .
ESD protective wrist band	-	

### Required documents

Document	Article number	Note
<i>Circuit diagram - OmniCore V250XT, rev 04 or later</i>	3HAC074000-008	

*Continues on next page*

## 5 Repair

---

### 5.2.2.1.1 Replacing the external fans

### 5.2.2.1 Replacing the external fans

#### 5.2.2.1.1 Replacing the external fans

---

##### Location

The illustration shows the location of the external fan in the controller.

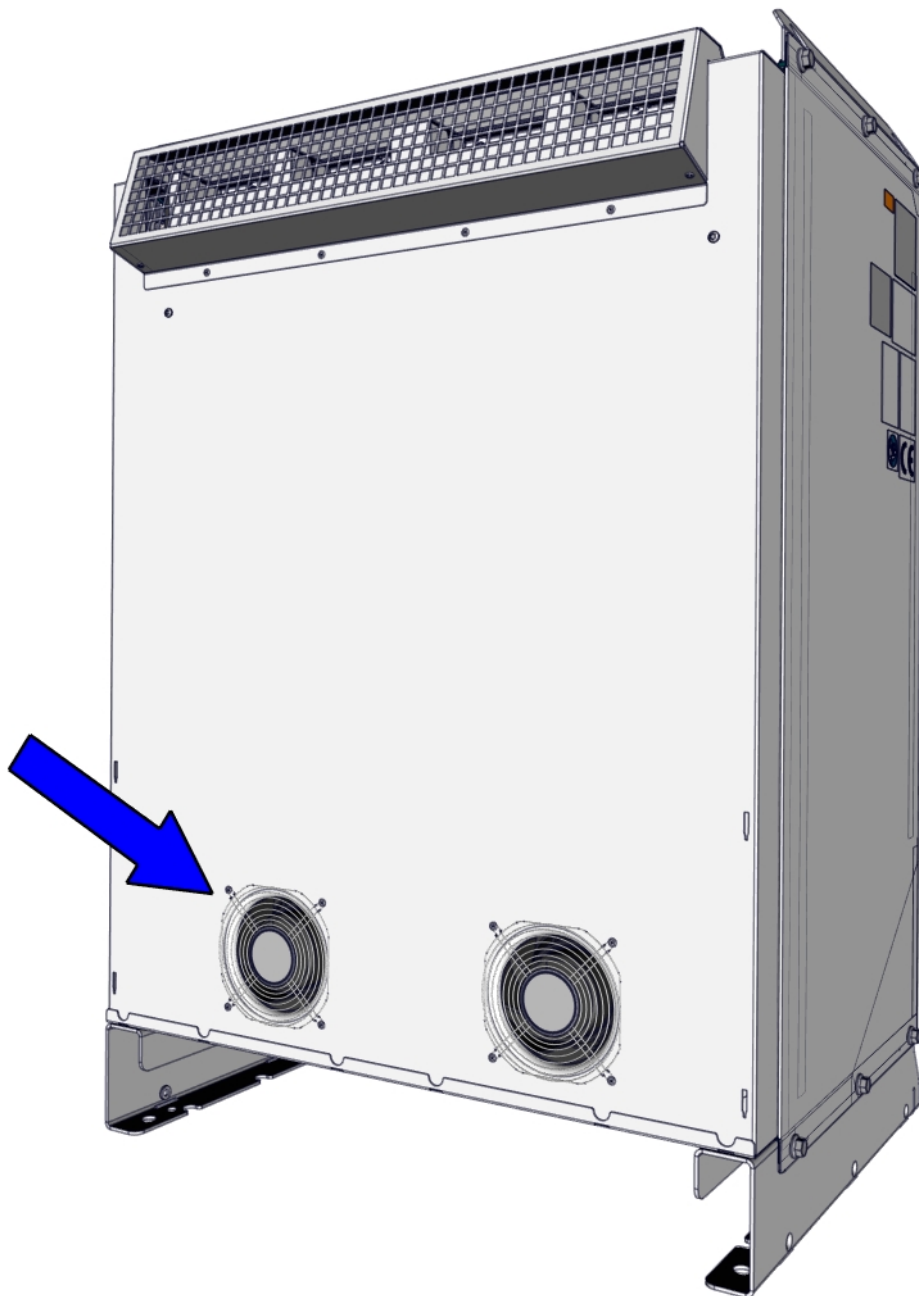



xx2200001778

*Continues on next page*

Removing the external fans

Preparations

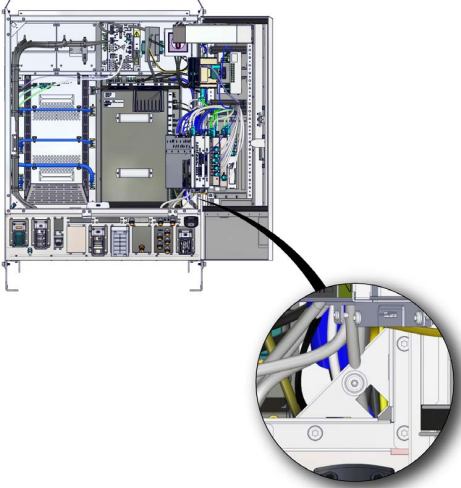
	Action	Note/Illustration
1	 <b>DANGER</b> Before doing any work inside the cabinet, disconnect the mains power. For more information, see <a href="#">Electrical safety on page 29</a> .	
2	 <b>ELECTROSTATIC DISCHARGE (ESD)</b> The unit is sensitive to ESD. Before handling the unit read the safety information in section <a href="#">The unit is sensitive to ESD on page 45</a> .	Location of wrist strap button:  xx2200001817
3	Remove the rear cover of the controller.	<a href="#">Removing the rear cover on page 190</a> .

Removing the external fans

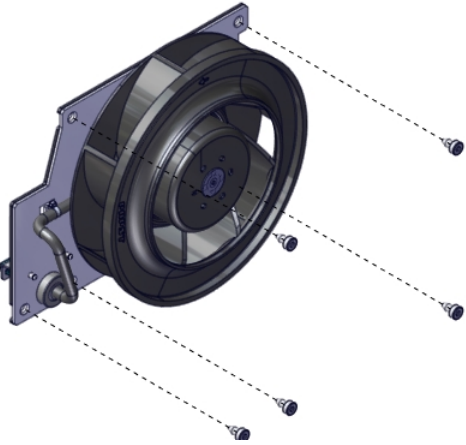
	Action	Note/Illustration
1	Disconnect all connectors from the unit to be replaced.	
2	Remove the fan bracket screws.	 xx2200001063
3	Take out the fan bracket and the fan.	

Continues on next page

## 5 Repair

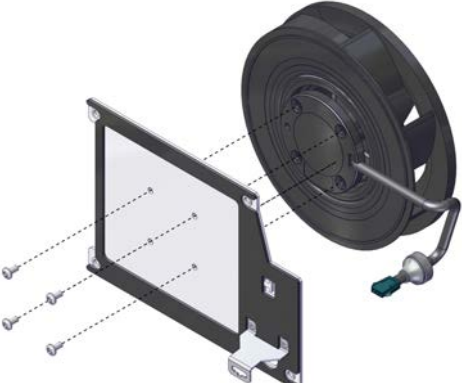

### 5.2.2.1.1 Replacing the external fans

*Continued*

	Action	Note/Illustration
4	Cut the cable ties and remove the screws that hold the fan to the bracket.	 <p>xx2200001064</p>

### Refitting the external fans

Refitting the external fans

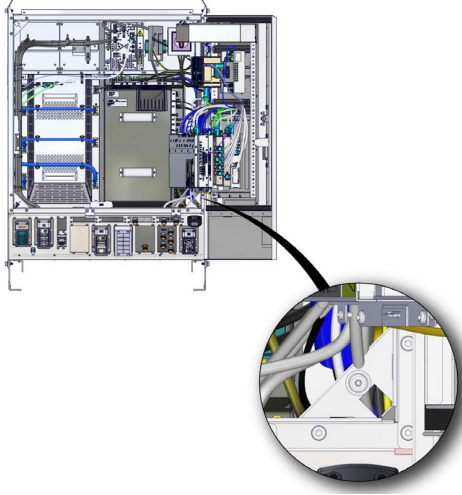
	Action	Note/Illustration
1	 <p><b>DANGER</b></p> <p>Before doing any work inside the cabinet, disconnect the mains power. For more information, see <a href="#">Electrical safety on page 29</a>.</p>	
2	 <p><b>ELECTROSTATIC DISCHARGE (ESD)</b></p> <p>The unit is sensitive to ESD. Before handling the unit read the safety information in section <a href="#">The unit is sensitive to ESD on page 45</a>.</p>	<p>Location of wrist strap button:</p>  <p>xx2200001817</p>

*Continues on next page*

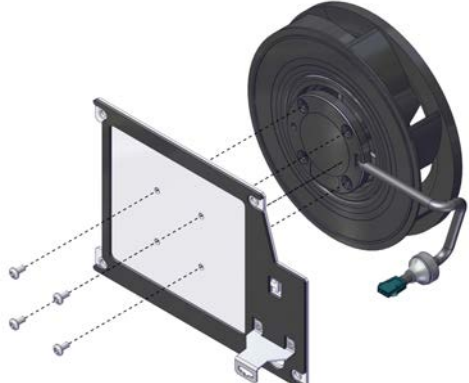
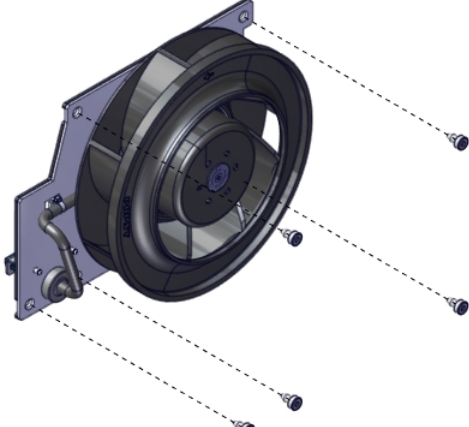

	Action	Note/Illustration
3	Place the external fan in the bracket and secure it with the screws and cable ties.	 <p>xx2200001064</p>
4	Position the fan bracket in the controller and secure the screws.	 <p>xx2200001063</p>
5	Reconnect any connectors disconnected at removal.	

Concluding procedure

	Action	Note/Illustration
1	Refit the rear cover of the controller.	<a href="#">Refitting the rear cover on page 191.</a>
2	Make sure that the filter cover plate is correctly positioned.	
3	Perform the function tests to verify that the safety features work properly, see <a href="#">Function tests on page 177.</a>	

## 5 Repair

### 5.2.2.2 Replacing the internal fan

#### 5.2.2.2 Replacing the internal fan

##### Location

The illustration shows the location of the internal fan in the controller.

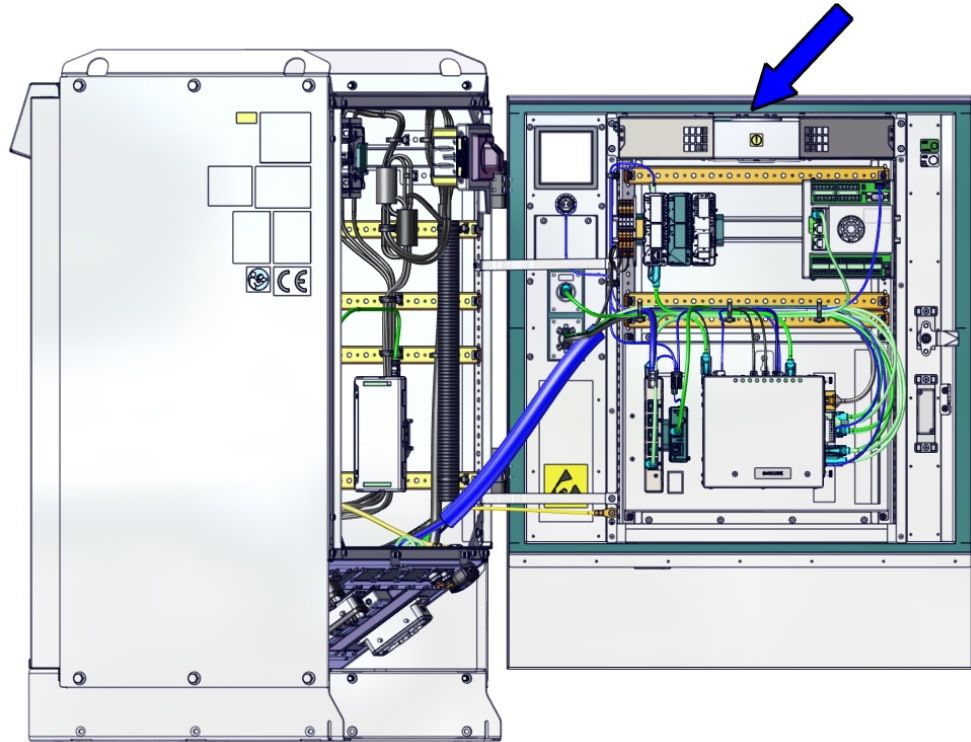

xx2300001834

##### Removing the internal fan

##### Preparations

	Action	Note/Illustration
1	 <b>DANGER</b> Before doing any work inside the cabinet, disconnect the mains power. For more information, see <a href="#">Electrical safety on page 29</a> .	
2	Open the door.	<a href="#">Opening the door on page 188</a> .

*Continues on next page*

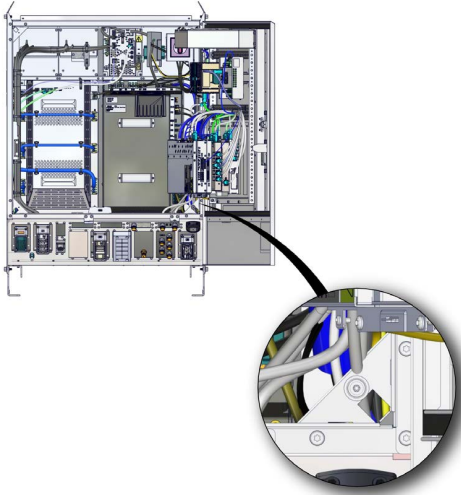
	Action	Note/Illustration
3	 <p><b>ELECTROSTATIC DISCHARGE (ESD)</b></p> <p>The unit is sensitive to ESD. Before handling the unit read the safety information in section <i>The unit is sensitive to ESD on page 45.</i></p>	<p>Location of wrist strap button:</p>  <p>xx2200001817</p>

Removing the internal fan

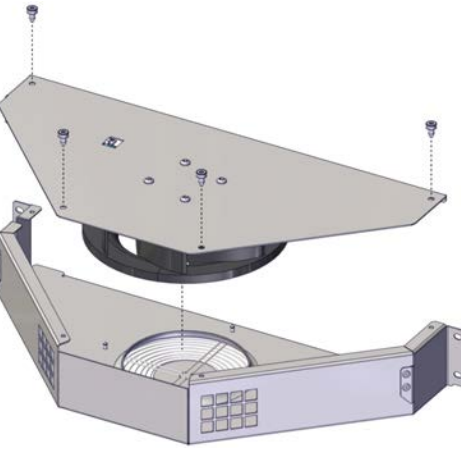
	Action	Note/Illustration
1	<p>Disconnect all connectors from the unit to be replaced.</p>	
2	<p>Remove the screws holding the fan assembly.</p>	 <p>xx2200001069</p>
3	<p>Remove the fan assembly from the mounting plate.</p>	
4	<p>Remove the screws holding the fan cover.</p>	 <p>xx2200001070</p>
5	<p>Remove any cable ties.</p>	

Continues on next page

## 5 Repair

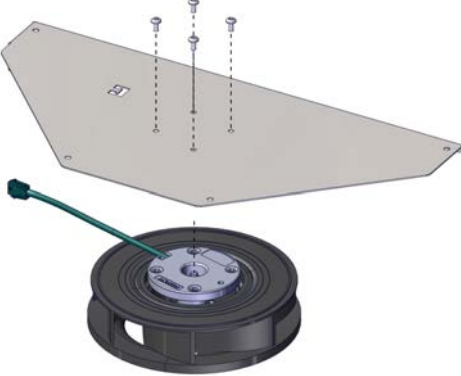

### 5.2.2.2 Replacing the internal fan

Continued



	Action	Note/Illustration
6	Remove the internal fan attachment screws.	 <p>xx2200001071</p>

### Refitting the internal fan

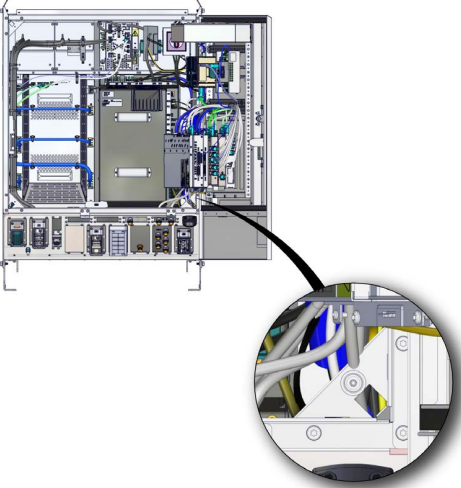
Refitting the internal fan

	Action	Note/Illustration
1	 <p><b>DANGER</b></p> <p>Before doing any work inside the cabinet, disconnect the mains power. For more information, see <a href="#">Electrical safety on page 29</a>.</p>	
2	 <p><b>ELECTROSTATIC DISCHARGE (ESD)</b></p> <p>The unit is sensitive to ESD. Before handling the unit read the safety information in section <a href="#">The unit is sensitive to ESD on page 45</a>.</p>	<p>Location of wrist strap button:</p>  <p>xx2200001817</p>

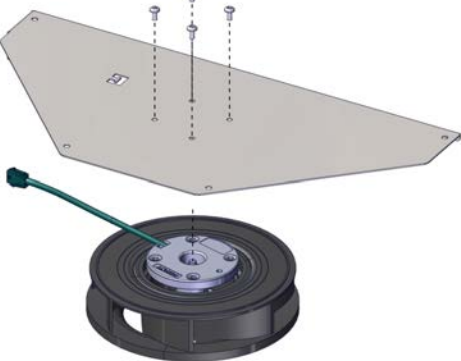
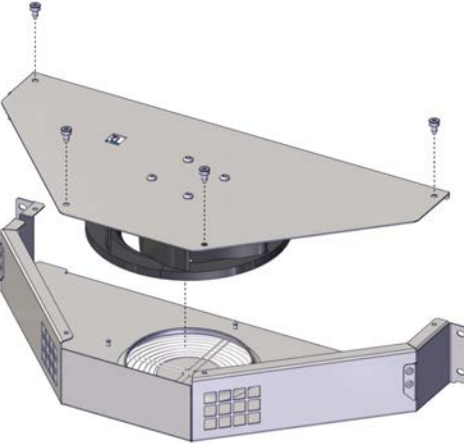
Continues on next page

	Action	Note/Illustration
3	Secure the internal fan attachment screws.	<p>Screws: Torx pan head screw M4x8 (4 pcs)</p>  <p>xx2200001071</p>
4	Refit the screws holding the fan cover.	 <p>xx2200001070</p>
5	Refit the screws holding the fan assembly.	 <p>xx2200001069</p>
6	Reconnect any connectors disconnected at removal.	

Concluding procedure

	Action	Note/Illustration
1	Close the door.	<a href="#">Closing the door on page 189.</a>
2	Perform the function tests to verify that the safety features work properly, see <a href="#">Function tests on page 177.</a>	

## 5 Repair

### 5.2.2.3 Replacing the main computer fan

#### 5.2.2.3 Replacing the main computer fan

##### Location

The illustration shows the location of the main computer fan in the controller.

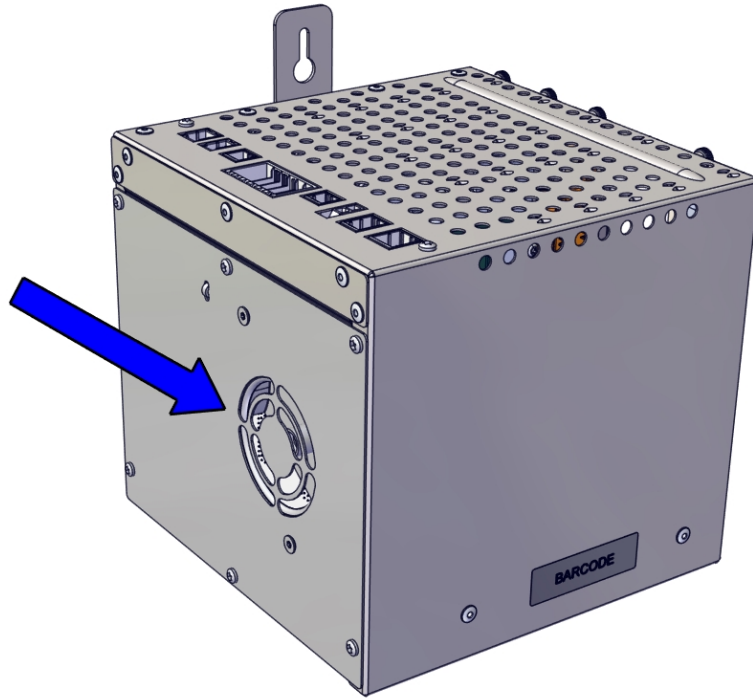

xx2300001552

##### Required spare parts



##### Note

The spare part numbers that are listed in the table can be out of date. See the latest spare parts of the OmniCore V250XT Type B via myABB Business Portal, [www.abb.com/myABB](http://www.abb.com/myABB).

Spare part	Article number	Note
Fan w/ contact	3HAC084390-001	Main computer fan

##### Required tools and equipment

Equipment	Article number	Note
Standard toolkit	-	Content is defined in section <a href="#">Standard toolkit for controller on page 436</a> .
ESD protective wrist band	-	



*Continues on next page*

Required documents

Document	Article number	Note
Circuit diagram - OmniCore V250XT, rev 04 or later	3HAC074000-008	

Removing the main computer fan

Preparations

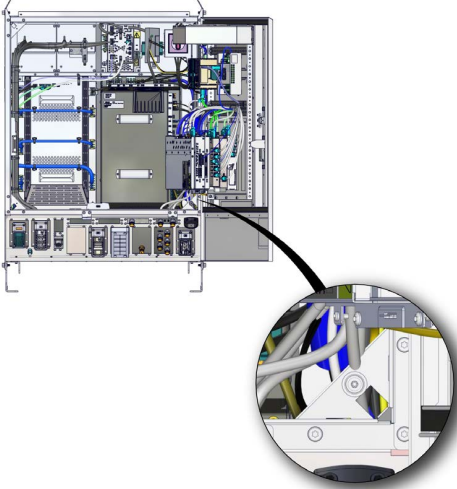
	Action	Note/Illustration
1	 <p><b>DANGER</b></p> <p>Before doing any work inside the cabinet, disconnect the mains power. For more information, see <a href="#">Electrical safety on page 29</a>.</p>	
2	Open the door.	<a href="#">Opening the door on page 188</a> .
3	 <p><b>ELECTROSTATIC DISCHARGE (ESD)</b></p> <p>The unit is sensitive to ESD. Before handling the unit read the safety information in section <a href="#">The unit is sensitive to ESD on page 45</a>.</p>	<p>Location of wrist strap button:</p>  <p>xx2200001817</p>
4	If necessary, remove the Connected Services gateway.	<a href="#">Removing the Connected Services gateway on page 215</a> .

Continues on next page

## 5 Repair

### 5.2.2.3 Replacing the main computer fan

*Continued*

#### Removing the main computer fan

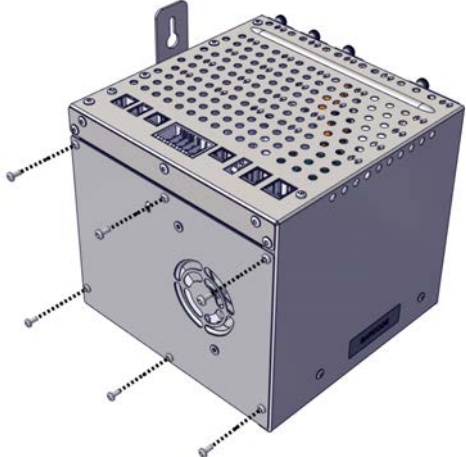
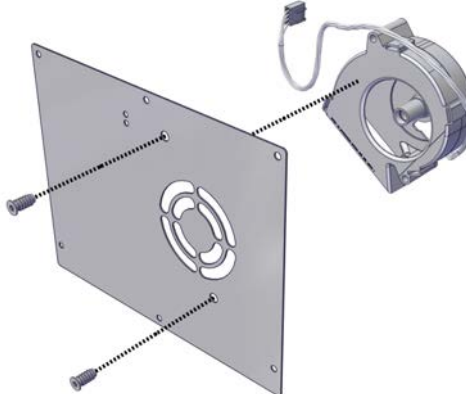
	Action	Note/Illustration
1	Remove the screws that hold the fan bracket.	 <p>xx2300001551</p>
2	Remove the fan bracket from the main computer.	
3	Disconnect all connectors from the unit to be replaced.	
4	Remove the fan from the bracket.	 <p>xx2200001090</p>

#### Refitting the main computer fan

##### Preparations

	Action	Note/Illustration
1	 <p><b>DANGER</b></p> <p>Before doing any work inside the cabinet, disconnect the mains power. For more information, see <a href="#">Electrical safety on page 29</a>.</p>	

*Continues on next page*

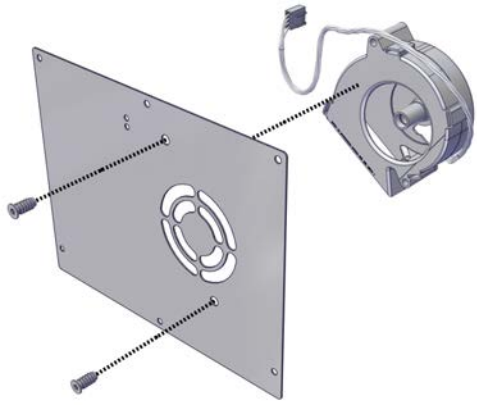
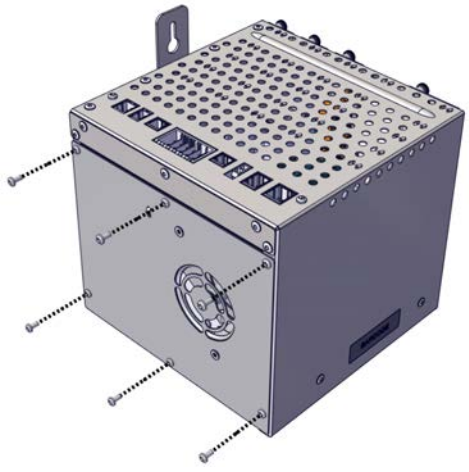

Refitting the main computer fan

	Action	Note/Illustration
1	Place the main computer fan in the bracket and secure with the screws and cable ties.	 <p>xx2200001090</p> <p>Screws: Torx T10 (2 pcs) Tightening torque: 0.7 Nm</p>
2	Reconnect any connectors disconnected at removal.	
3	Refit the fan bracket in the main computer and secure the screws.	 <p>xx2300001551</p> <p>Screws: Torx T10 (6 pcs) Tightening torque: 0.7 Nm</p>

Concluding procedure

	Action	Note/Illustration
1	If necessary, refit the Connected Services gateway.	<a href="#">Refitting the Connected Services gateway on page 218.</a>
2	Close the door.	<a href="#">Closing the door on page 189.</a>
3	Perform the function tests to verify that the safety features work properly, see <a href="#">Function tests on page 177.</a>	

## 5 Repair

### 5.2.2.4 Replacing the power unit fan

#### 5.2.2.4 Replacing the power unit fan

##### Location

The illustration shows the location of the power unit computer fan in the controller.

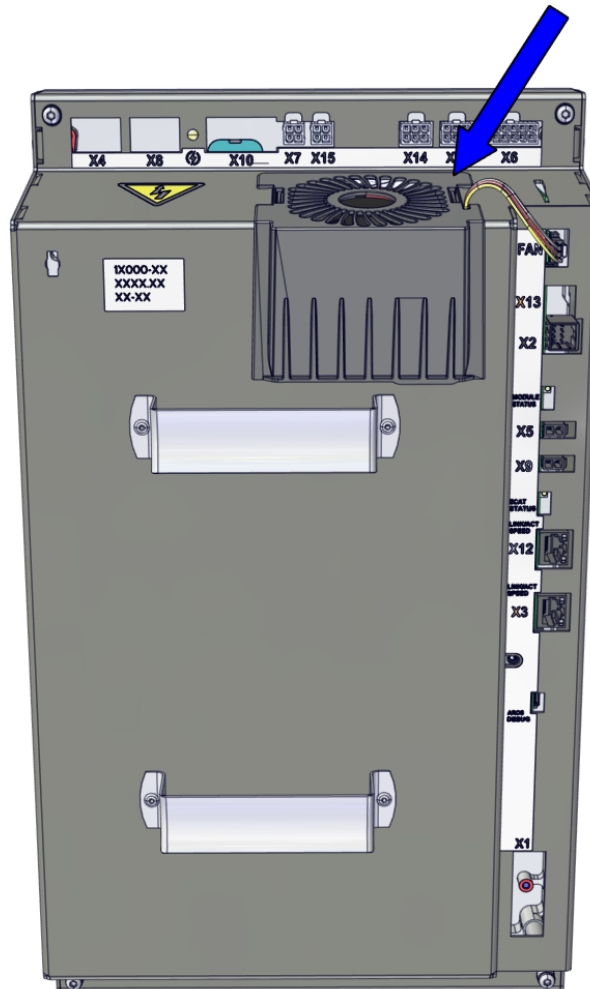

xx2100002281

##### Required spare parts



##### Note

The spare part numbers that are listed in the table can be out of date. See the latest spare parts of the OmniCore V250XT Type B via myABB Business Portal, [www.abb.com/myABB](http://www.abb.com/myABB).

Spare part	Article number	Note
Fan with connector	3HAC081496-001	Power unit fan

Continues on next page

Required tools and equipment



Equipment	Article number	Note
Standard toolkit	-	Content is defined in section <a href="#">Standard toolkit for controller on page 436</a> .
ESD protective wrist band	-	

Required documents

Document	Article number	Note
<i>Circuit diagram - OmniCore V250XT</i> , rev 04 or later	3HAC074000-008	

Removing the power unit fan

Preparations

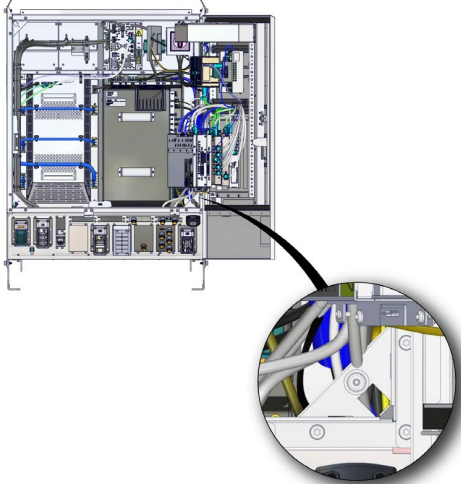
	Action	Note/Illustration
1	 <b>DANGER</b> Before doing any work inside the cabinet, disconnect the mains power. For more information, see <a href="#">Electrical safety on page 29</a> .	
2	Open the door.	<a href="#">Opening the door on page 188</a> .
3	 <b>ELECTROSTATIC DISCHARGE (ESD)</b> The unit is sensitive to ESD. Before handling the unit read the safety information in section <a href="#">The unit is sensitive to ESD on page 45</a> .	Location of wrist strap button:  xx2200001817
4	Verify that the LED High voltage warning is not lit.	<a href="#">LEDs on page 392</a> .

Removing the power unit fan

	Action	Note/Illustration
1	Disconnect all connectors from the unit to be replaced.	

Continues on next page

## 5 Repair



### 5.2.2.4 Replacing the power unit fan

*Continued*

	Action	Note/Illustration
2	Lift the edge of the bracket and pull the fan assembly carefully out from the power unit.	
3	Take out the fan from the bracket.	

### Refitting the power unit fan

Refitting the power unit fan

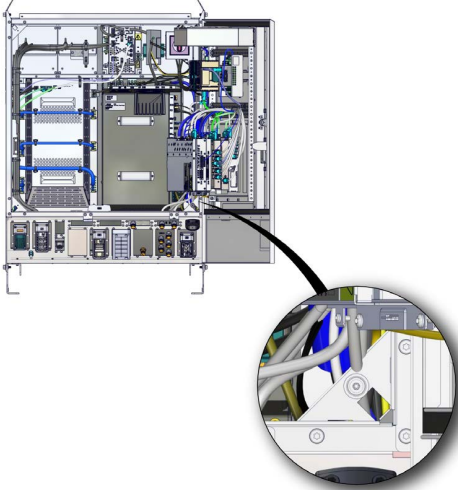
	Action	Note/Illustration
1	 <b>DANGER</b> Before doing any work inside the cabinet, disconnect the mains power. For more information, see <a href="#">Electrical safety on page 29</a> .	
2	 <b>ELECTROSTATIC DISCHARGE (ESD)</b> The unit is sensitive to ESD. Before handling the unit read the safety information in section <a href="#">The unit is sensitive to ESD on page 45</a> .	Location of wrist strap button:  xx2200001817
3	Place the power unit fan in the bracket.	

*Continues on next page*

5.2.2.4 Replacing the power unit fan  
Continued

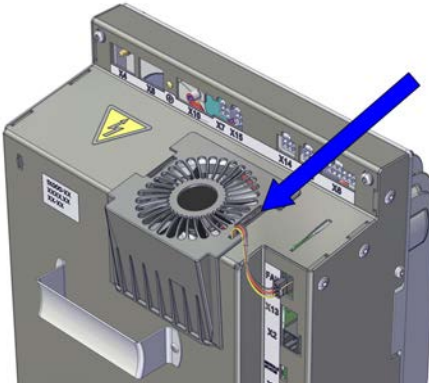
	Action	Note/Illustration
4	Insert the fan assembly in the slot on the power unit.	 <p data-bbox="954 716 1061 739">xx2100002282</p> <p data-bbox="957 761 1157 817"><b>!</b> CAUTION</p> <p data-bbox="954 828 1436 884">Sharp edges. Make sure the cables are not damaged.</p>
5	Reconnect any connectors disconnected at removal.	

Concluding procedure

	Action	Note/Illustration
1	Close the door.	<a href="#">Closing the door on page 189.</a>
2	Perform the function tests to verify that the safety features work properly, see <a href="#">Function tests on page 177.</a>	

## 5 Repair

### 5.2.3 Replacing the Ethernet switch (DSQC1035)

### 5.2.3 Replacing the Ethernet switch (DSQC1035)

#### Location

The illustration shows the location of the Ethernet switch in the controller.

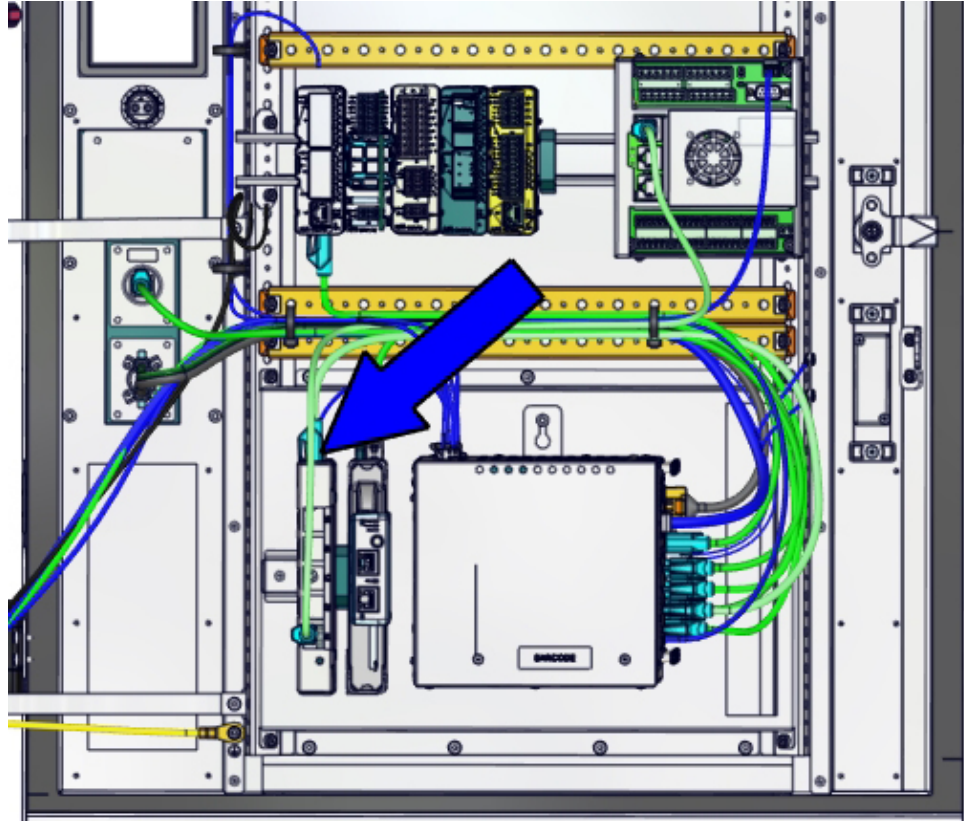

xx2300001820

#### Required spare parts



#### Note

The spare part numbers that are listed in the table can be out of date. See the latest spare parts of the OmniCore V250XT Type B via myABB Business Portal, [www.abb.com/myABB](http://www.abb.com/myABB).

Spare part	Article number	Note
Ethernet Extension switch [3014-1]	3HAC059187-001	DSQC1035
Ethernet Harness	3HAC084152-001	Harness A2.X4 - K4.X6

#### Required tools and equipment

Equipment	Article number	Note
Standard toolkit	-	Content is defined in section <a href="#">Standard toolkit for controller on page 436</a> .

Continues on next page



Equipment	Article number	Note
ESD protective wrist band	-	

Required documents

Document	Article number	Note
Circuit diagram - OmniCore V250XT, rev 04 or later	3HAC074000-008	

Removing the Ethernet extension switch (option)

Preparations

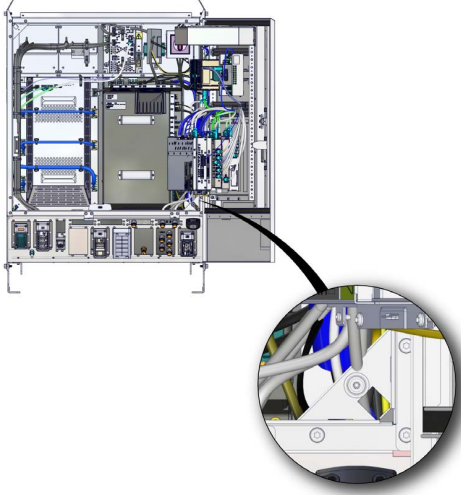
	Action	Note/Illustration
1	 <p><b>DANGER</b></p> <p>Before doing any work inside the cabinet, disconnect the mains power. For more information, see <a href="#">Electrical safety on page 29</a>.</p>	
2	Open the door.	<a href="#">Opening the door on page 188</a> .
3	 <p><b>ELECTROSTATIC DISCHARGE (ESD)</b></p> <p>The unit is sensitive to ESD. Before handling the unit read the safety information in section <a href="#">The unit is sensitive to ESD on page 45</a>.</p>	<p>Location of wrist strap button:</p>  <p>xx2200001817</p>

Removing the Ethernet extension switch (option)

	Action	Note/Illustration
1	Disconnect all connectors from the unit to be replaced.	

Continues on next page

## 5 Repair

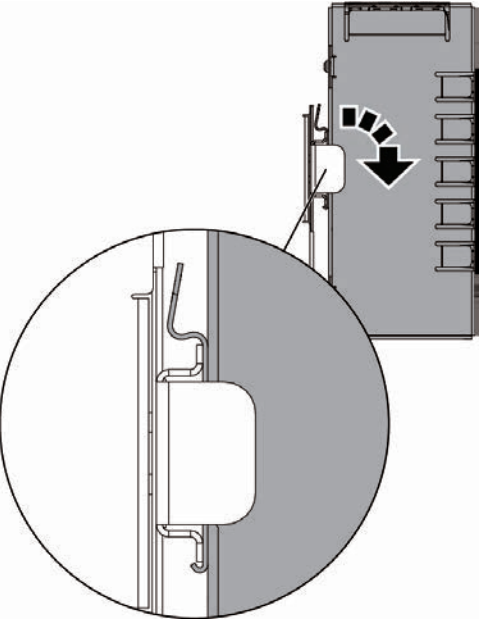

### 5.2.3 Replacing the Ethernet switch (DSQC1035)

Continued

	Action	Note/Illustration
2	Carefully pull the side of the Ethernet extension switch and rotate it tightly to take it out from the bracket.	 <p>xx2300001835</p>

### Refitting the Ethernet extension switch (option)

Refitting the Ethernet extension switch (option)

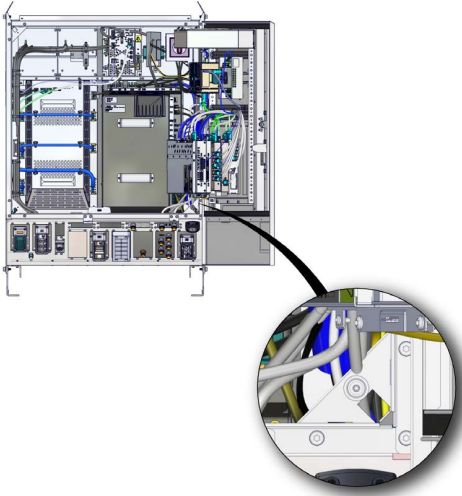
	Action	Note/Illustration
1	 <p><b>DANGER</b></p> <p>Before doing any work inside the cabinet, disconnect the mains power. For more information, see <a href="#">Electrical safety on page 29</a>.</p>	
2	 <p><b>ELECTROSTATIC DISCHARGE (ESD)</b></p> <p>The unit is sensitive to ESD. Before handling the unit read the safety information in section <a href="#">The unit is sensitive to ESD on page 45</a>.</p>	<p>Location of wrist strap button:</p>  <p>xx2200001817</p>

Continues on next page

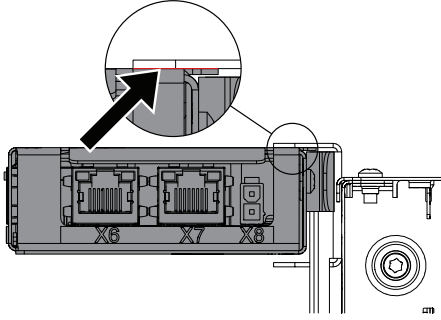
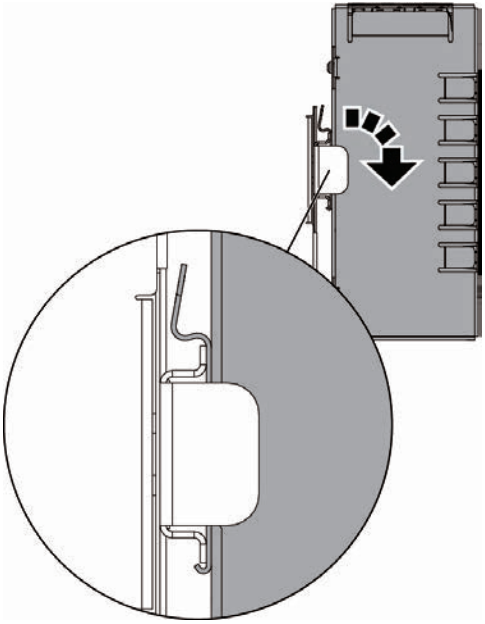

	Action	Note/Illustration
3	<p>Hook up the Ethernet extension switch to the bracket and then push the switch into position.</p> <p> <b>Note</b></p> <p>During the installation, there should be no gap between the upper surface of the Ethernet extension switch and the lower surface of highest bracket on the main computer.</p>  <p>xx1800000972</p>	 <p>xx2300001835</p>
4	<p>Reconnect any connectors disconnected at removal.</p>	

Concluding procedure

	Action	Note/Illustration
1	<p>Close the door.</p>	<p><a href="#">Closing the door on page 189.</a></p>
2	<p>Perform the function tests to verify that the safety features work properly, see <a href="#">Function tests on page 177.</a></p>	

## 5 Repair

### 5.2.4 Replacing the 3G Connected Services gateway

### 5.2.4 Replacing the 3G Connected Services gateway

#### Location

The illustration shows the location of the Connected Services gateway in the controller. For the 3G variant, there is a sim card inside the unit.

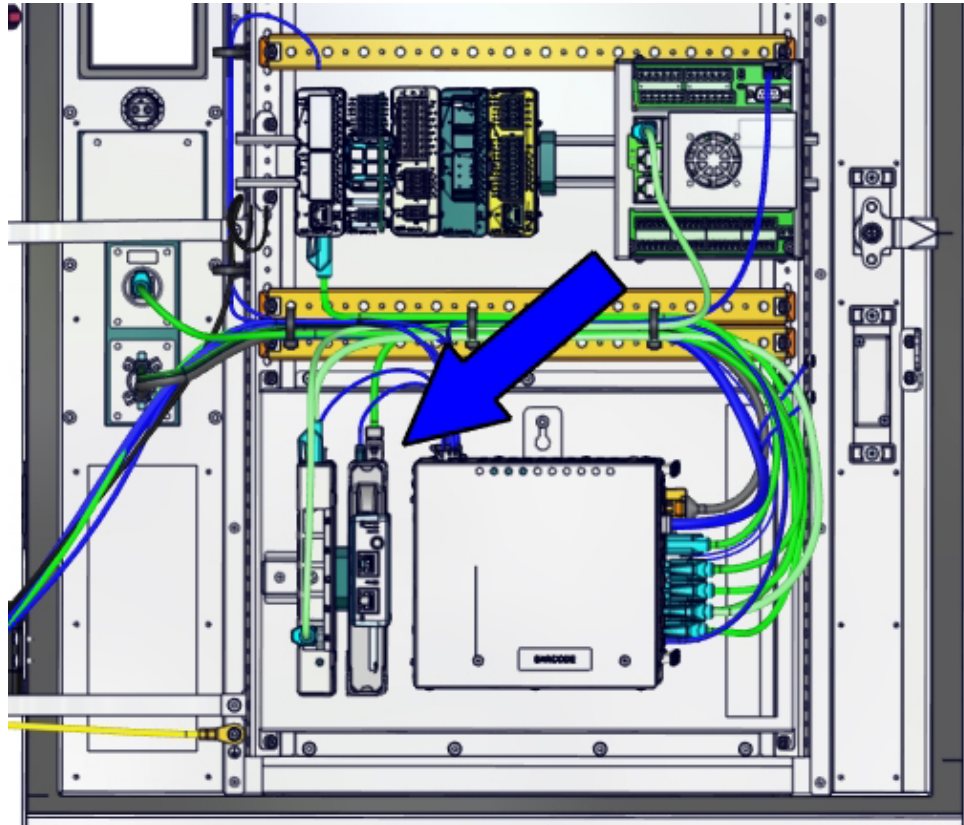

xx2300001805

#### Required spare parts



#### Note

The spare part numbers that are listed in the table can be out of date. See the latest spare parts of the OmniCore V250XT Type B via myABB Business Portal, [www.abb.com/myABB](http://www.abb.com/myABB).

Spare part	Article number	Note
Connected Services-3G [3013-3]	3HAC060960-001	DSQC1039
Magnetic roof antenna, 3G	3HAC028459-001	
Connected Services-WiFi [3013-2]	3HAC060962-001	DSQC1040
Magnetic roof antenna, WiFi	3HAC059424-001	
Connected Services-Wired [3013-1]	3HAC061701-001	DSQC1041

*Continues on next page*

5.2.4 Replacing the 3G Connected Services gateway  
Continued

Required tools and equipment



Equipment	Article number	Note
Standard toolkit	-	Content is defined in section <a href="#">Standard toolkit for controller on page 436</a> .
ESD protective wrist band	-	

Required documents

Document	Article number	Note
<i>Circuit diagram - OmniCore V250XT</i> , rev 04 or later	3HAC074000-008	

Removing the Connected Services gateway

Preparations

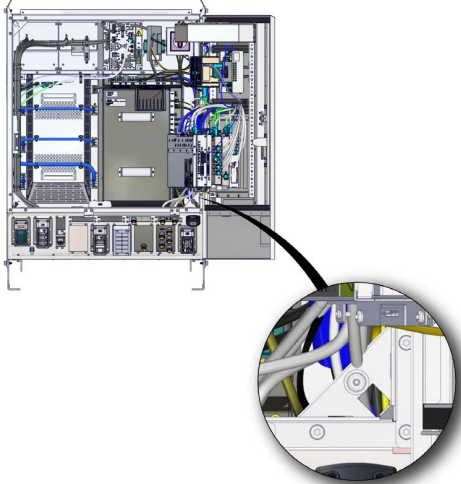
	Action	Note/Illustration
1	 <b>DANGER</b> Before doing any work inside the cabinet, disconnect the mains power. For more information, see <a href="#">Electrical safety on page 29</a> .	
2	Open the door.	<a href="#">Opening the door on page 188</a> .
3	 <b>ELECTROSTATIC DISCHARGE (ESD)</b> The unit is sensitive to ESD. Before handling the unit read the safety information in section <a href="#">The unit is sensitive to ESD on page 45</a> .	Location of wrist strap button:  xx2200001817

Continues on next page

## 5 Repair

### 5.2.4 Replacing the 3G Connected Services gateway

*Continued*

#### Disconnecting the antenna

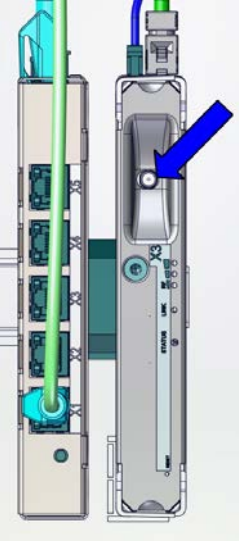
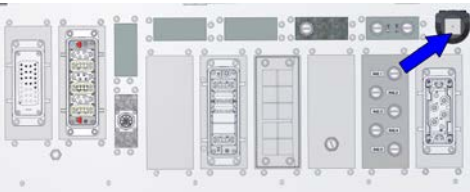
	Action	Note/Illustration
1	Record the cable routing when you remove the antenna cable from the cabinet.	 <b>Note</b> The Connected Services antenna is installed by the customer, and the cable routing can therefore differ.
2	Disconnect the antenna cable from the Connected Services gateway by rotating the connector.	 <p>xx2300001642</p>
3	Remove any cable ties and protection.	
4	Pull the cable out through the cable grommet.	 <p>xx2200001973</p>
5	Remove the magnet part of the antenna from the cabinet.	

#### Removing the Connected Services gateway

	Action	Note/Illustration
1	Disconnect all connectors from the unit to be replaced.	

*Continues on next page*

5.2.4 Replacing the 3G Connected Services gateway  
Continued

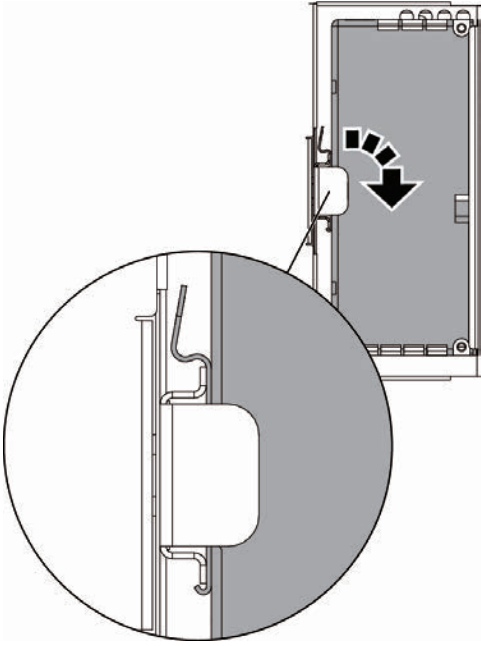
	Action	Note/Illustration
2	Carefully pull the side of the Connected Services gateway and rotate it tightly to take it out from the bracket.	 <p>xx2300001836</p>

Removing the sim card

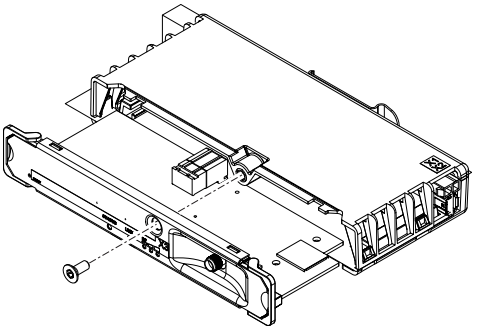
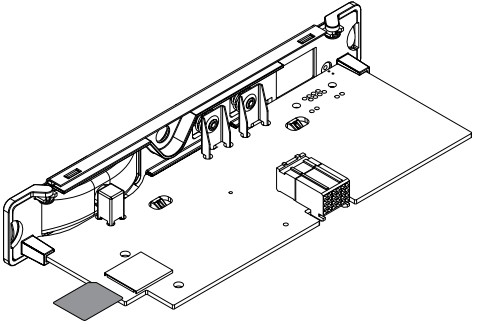
	Action	Note/Illustration
1	Remove the attachment screws and pull out the front cover of the Connected Services-3G.	 <p>xx1900000971</p>
2	Carefully pull out the sim card from its holder.	 <p>xx1900000972</p>

Continues on next page

## 5 Repair

### 5.2.4 Replacing the 3G Connected Services gateway



*Continued*

#### Refitting the Connected Services gateway

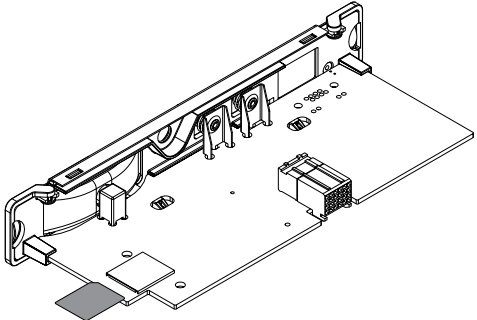
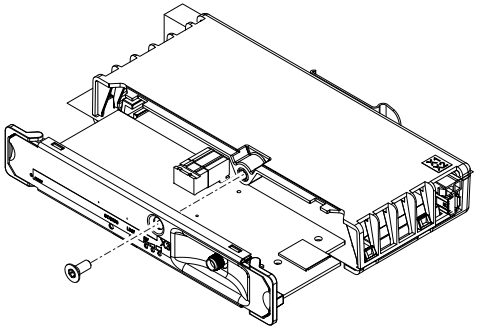
##### Refitting the sim card

	Action	Note/Illustration
1	Carefully place the sim card in its holder.	 <p>xx1900000972</p>
2	Refit the front cover of the Connected Services-3G and secure the screws.	 <p>xx1900000971</p>

#### Refitting the Connected Services gateway



	Action	Note/Illustration
1	 <b>DANGER</b> Before doing any work inside the cabinet, disconnect the mains power. For more information, see <a href="#">Electrical safety on page 29</a> .	
2	 <b>ELECTROSTATIC DISCHARGE (ESD)</b> The unit is sensitive to ESD. Before handling the unit read the safety information in section <a href="#">The unit is sensitive to ESD on page 45</a> .	

*Continues on next page*

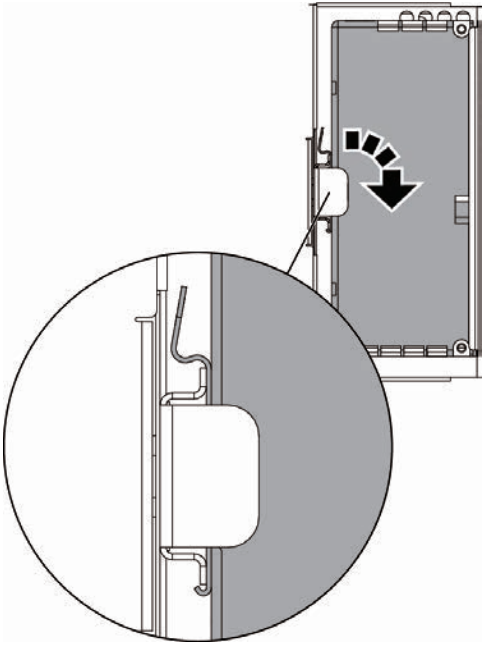
5.2.4 Replacing the 3G Connected Services gateway  
Continued

	Action	Note/Illustration
3	Hook up the Connected Services gateway to the bracket and push carefully into position.	 <p>xx2300001836</p>
4	Reconnect any connectors disconnected at removal.	

Reconnecting the antenna

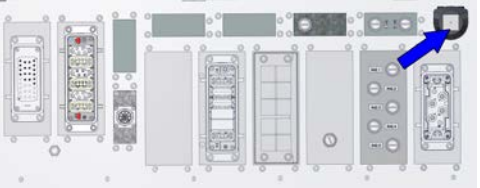
	Action	Note/Illustration
1	Place the magnet part of the antenna on the outside of the cabinet.	 <b>Note</b> The operating conditions must be such that there is a minimum separation distance of 20 cm between the dedicated antenna and nearby persons.
2	Follow the cable routing recorded during the disassembly when you reconnect the antenna cable.	 <b>Note</b> The Connected Services antenna is installed by the customer, and the cable routing can therefore differ.
3	Insert the antenna cable through the cable grommet.	 <p>xx2200001973</p>
4	Apply cable ties and suitable cable protection to ensure that the cable may not be damaged by the door.	

Continues on next page

## 5 Repair

### 5.2.4 Replacing the 3G Connected Services gateway

*Continued*

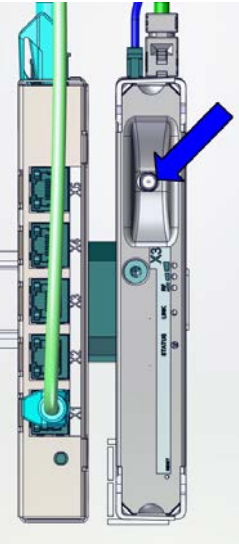
	Action	Note/Illustration
5	Connect the antenna cable to the Connected Services gateway by rotating the connector.	 <p>xx2300001642</p>

#### Concluding procedure

	Action	Note/Illustration
1	Close the door.	<i>Closing the door on page 189.</i>
2	Perform the function tests to verify that the safety features work properly, see <i>Function tests on page 177.</i>	



## 5.2.5 Replacing the 4G Connected Services gateway

### Location

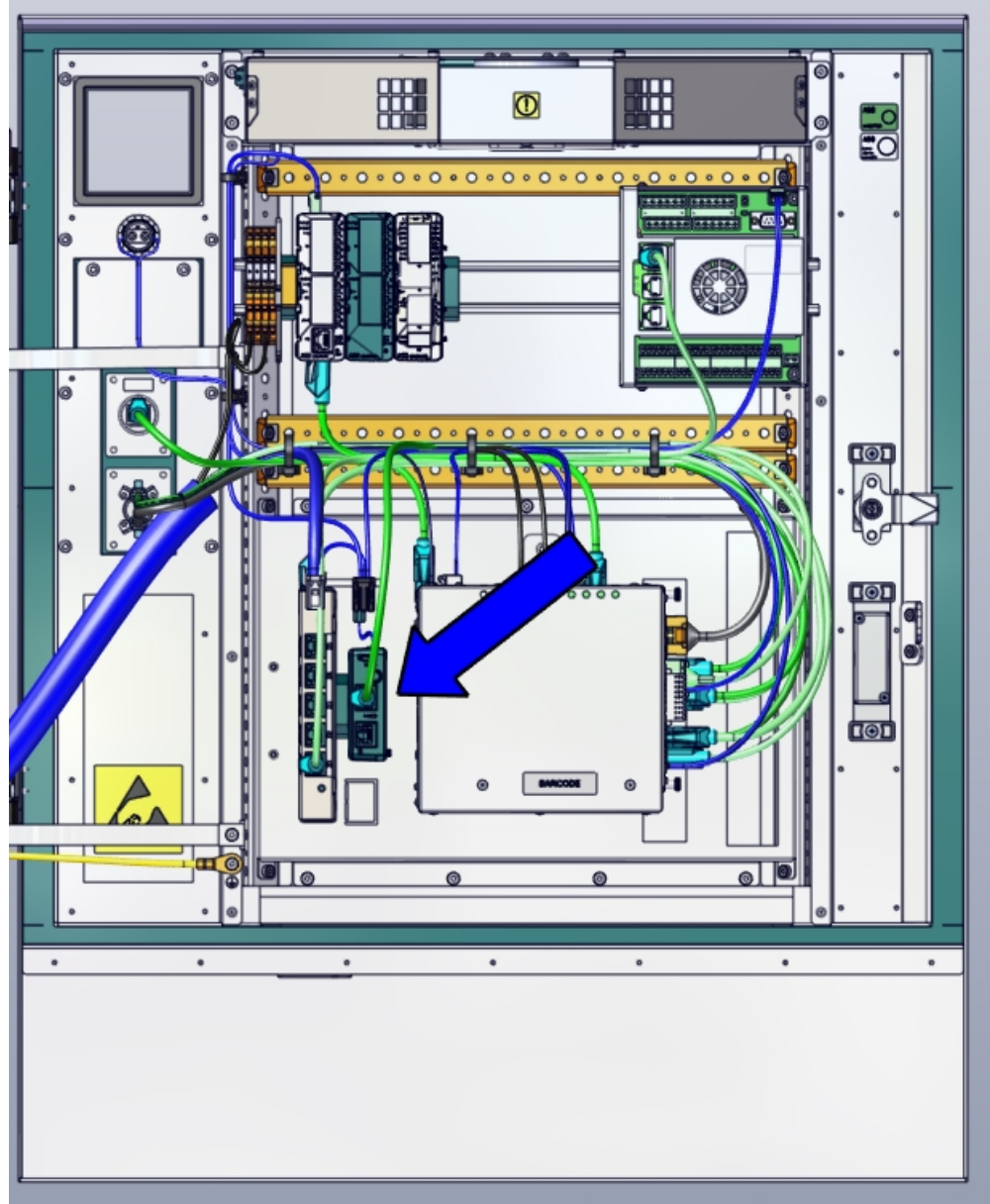

xx2300001806

### Required spare parts



#### Note

The spare part numbers that are listed in the table can be out of date. See the latest spare parts of the OmniCore V250XT Type B via myABB Business Portal, [www.abb.com/myABB](http://www.abb.com/myABB).

*Continues on next page*

## 5 Repair

### 5.2.5 Replacing the 4G Connected Services gateway

Continued

Spare part	Article number	Note
Connected Services 4G EU [3013-5]	3HAC086677-001	DSQC1093
Connected Services 4G US [3013-6]	3HAC086678-001	DSQC1093A
Magnetic roof antenna 4G	3HAC086604-001	
Ethernet harness	3HAC085903-001	Harness A2.K4.X1 - K7.ETH2
24V Adapter harness	3HAC085904-001	Harness Adapter - K7.X1

#### Required tools and equipment

Equipment	Article number	Note
Standard toolkit	-	Content is defined in section <a href="#">Standard toolkit for controller on page 436</a> .
ESD protective wrist band	-	

#### Required documents

Document	Article number	Note
<i>Circuit diagram - OmniCore V250XT, rev 04 or later</i>	3HAC074000-008	

#### Removing the Connected Services gateway

##### Preparations

	Action	Note/Illustration
1	 <b>DANGER</b> Before doing any work inside the cabinet, disconnect the mains power. For more information, see <a href="#">Electrical safety on page 29</a> .	
2	Open the door.	<a href="#">Opening the door on page 188</a> .

Continues on next page

5.2.5 Replacing the 4G Connected Services gateway  
Continued

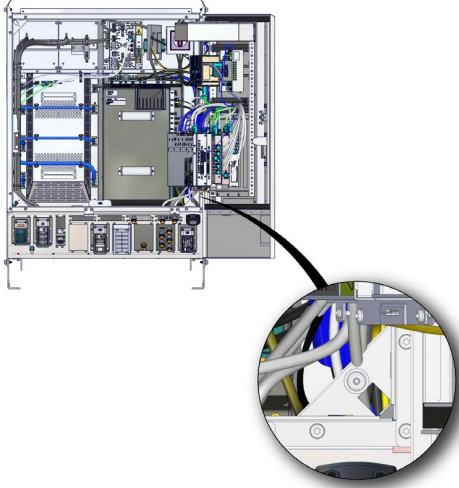
	Action	Note/Illustration
3	 <p><b>ELECTROSTATIC DISCHARGE (ESD)</b></p> <p>The unit is sensitive to ESD. Before handling the unit read the safety information in section <i>The unit is sensitive to ESD on page 45.</i></p>	<p>Location of wrist strap button:</p>  <p>xx2200001817</p>

Disconnecting the antenna

	Action	Note/Illustration
1	<p>Record the cable routing when you remove the antenna cable from the cabinet.</p>	 <p><b>Note</b></p> <p>The Connected Services antenna is installed by the customer, and the cable routing can therefore differ.</p>

Continues on next page

## 5 Repair

### 5.2.5 Replacing the 4G Connected Services gateway

Continued

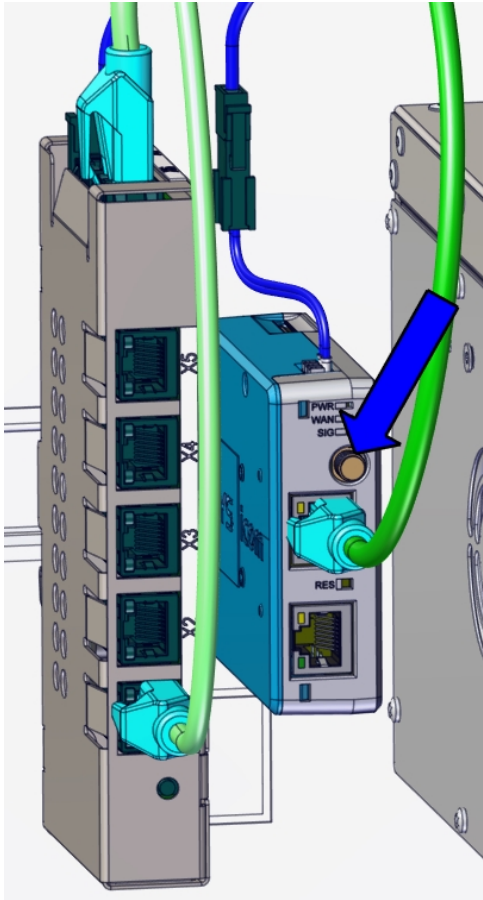
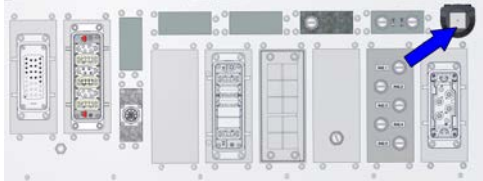

	Action	Note/Illustration
2	Disconnect the antenna cable from the Connected Services gateway by rotating the connector.	 <p>xx230000672</p>
3	Remove any cable ties and protection.	
4	Pull the cable out through the cable grommet.	 <p>xx2200001973</p>
5	Remove the magnet part of the antenna from the cabinet.	

#### Removing the Connected Services gateway

	Action	Note/Illustration
1	Disconnect all connectors from the unit to be replaced.	

Continues on next page

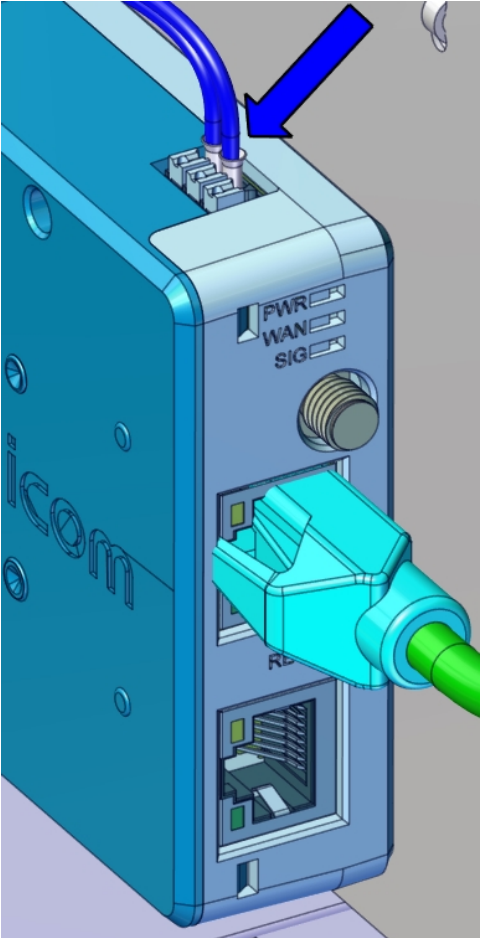
5.2.5 Replacing the 4G Connected Services gateway  
Continued

	Action	Note/Illustration
2	Disconnect the free ends of the 24V adapter harness: <ul style="list-style-type: none"> <li>• Wire K7-W201 from the 24V (V+) connection on the Connected Services gateway.</li> <li>• Wire K7-W202 from the 0V (V-) connection on the Connected Services gateway.</li> </ul>	 <p data-bbox="956 1249 1062 1272">xx230000753</p> <p data-bbox="959 1294 1015 1350"></p> <p data-bbox="1043 1310 1102 1339"><b>Note</b></p> <p data-bbox="956 1364 1417 1420">Press down the white button with a sharp object while pulling out the wire.</p>
3	Carefully lift the Connected Services gateway slightly and then pull it out from the bracket.	

Refitting the Connected Services gateway

Refitting the Connected Services gateway

	Action	Note/Illustration
1	 <p data-bbox="592 1765 699 1794"><b>DANGER</b></p> <p data-bbox="501 1823 943 1928">Before doing any work inside the cabinet, disconnect the mains power. For more information, see <a href="#">Electrical safety on page 29</a>.</p>	

Continues on next page

## 5 Repair

### 5.2.5 Replacing the 4G Connected Services gateway

Continued

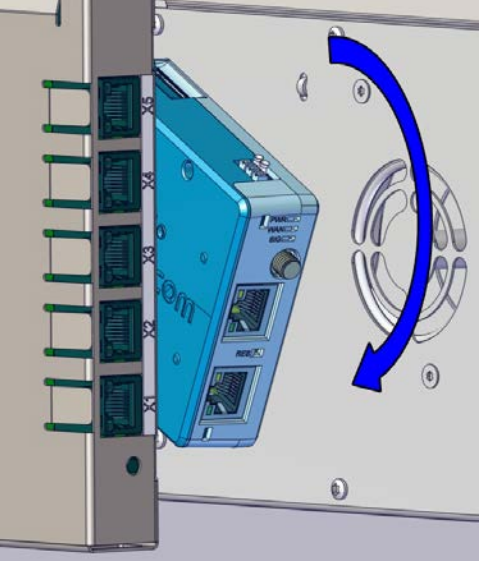

	Action	Note/Illustration
2	<p> <b>ELECTROSTATIC DISCHARGE (ESD)</b></p> <p>The unit is sensitive to ESD. Before handling the unit read the safety information in section <i>The unit is sensitive to ESD on page 45</i>.</p>	
3	<p>Hook up the Connected Services gateway to the bracket and push carefully into position.</p>	 <p>xx230000673</p>

Continues on next page

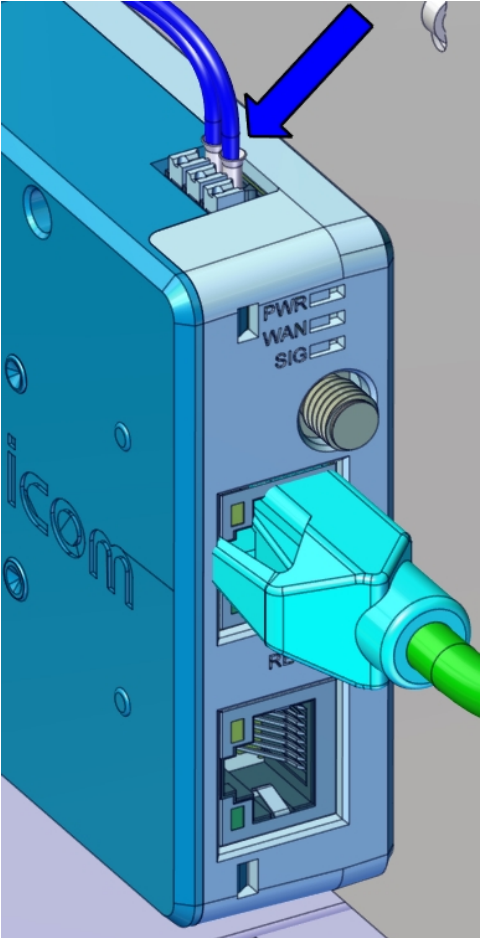
5.2.5 Replacing the 4G Connected Services gateway  
Continued

	Action	Note/Illustration
4	<p>Reconnect the free ends of the 24V adapter harness:</p> <ul style="list-style-type: none"> <li>• Wire K7-W201 to the 24V (V+) connection on the Connected Services gateway.</li> <li>• Wire K7-W202 to the 0V (V-) connection on the Connected Services gateway.</li> </ul>	 <p>xx230000753</p>
5	Reconnect any connectors disconnected at removal.	

Reconnecting the antenna

	Action	Note/Illustration
1	Place the magnet part of the antenna on the outside of the cabinet.	<p> <b>Note</b></p> <p>The operating conditions must be such that there is a minimum separation distance of 20 cm between the dedicated antenna and nearby persons.</p>
2	Follow the cable routing recorded during the disassembly when you reconnect the antenna cable.	<p> <b>Note</b></p> <p>The Connected Services antenna is installed by the customer, and the cable routing can therefore differ.</p>

Continues on next page

## 5 Repair

### 5.2.5 Replacing the 4G Connected Services gateway

*Continued*

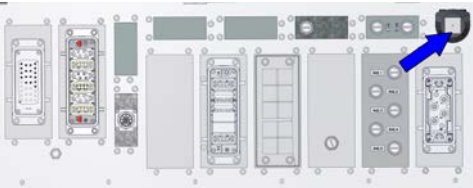
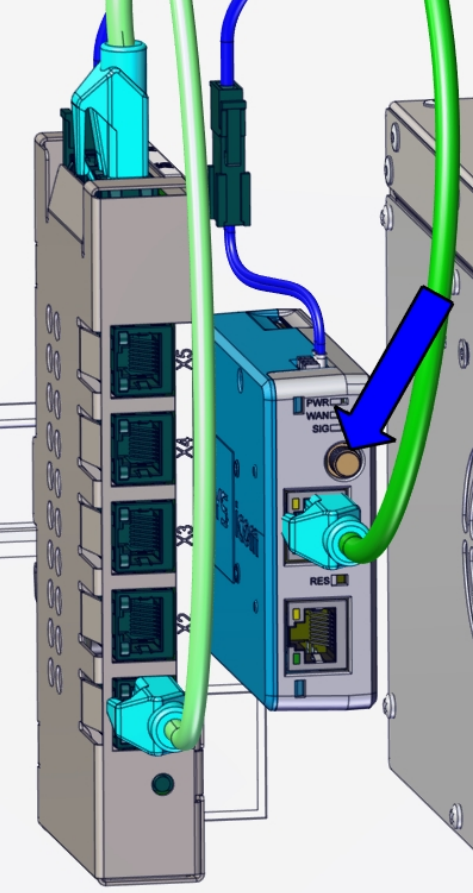
	Action	Note/Illustration
3	Insert the antenna cable through the cable grommet.	 <p>xx2200001973</p>
4	Apply cable ties and suitable cable protection to ensure that the cable may not be damaged by the door.	
5	Connect the antenna cable to the Connected Services gateway by rotating the connector.	 <p>xx2300000672</p>

#### Concluding procedure

	Action	Note/Illustration
1	Close the door.	<a href="#">Closing the door on page 189.</a>
2	Perform the function tests to verify that the safety features work properly, see <a href="#">Function tests on page 177.</a>	



## 5.2.6 Replacing the scalable I/O unit

### Location

The illustration shows the location of the scalable I/O in the controller.

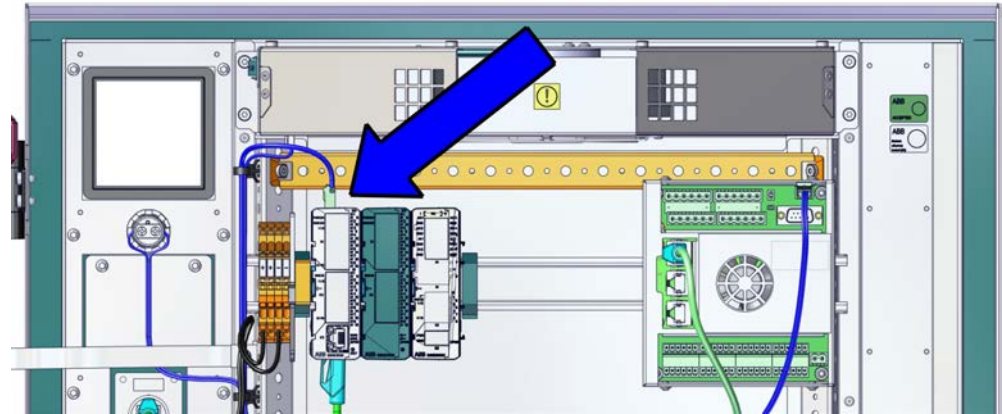

xx2300001818

### Required spare parts



#### Note

The spare part numbers that are listed in the table can be out of date. See the latest spare parts of the OmniCore V250XT Type B via myABB Business Portal, [www.abb.com/myABB](http://www.abb.com/myABB).

Spare part	Article number	Note
Local I/O Digital base [3032-1]	3HAC058663-001	DSQC1030
Connectors digital base/add on	3HAC060919-001	
Digital add-on [3033-2]	3HAC058664-001	DSQC1031
Analog add-on [3034-2]	3HAC058665-001	DSQC1032
Connectors I/O Analog	3HAC060925-001	
Relay add-on [3035-2]	3HAC058666-001	DSQC1033
Connectors I/O Relay	3HAC060926-001	

### Required tools and equipment

Equipment	Article number	Note
Standard toolkit	-	Content is defined in section <a href="#">Standard toolkit for controller on page 436</a> .
ESD protective wrist band	-	

*Continues on next page*

## 5 Repair

### 5.2.6 Replacing the scalable I/O unit



*Continued*

#### Required documents

Document	Article number	Note
<i>Circuit diagram - OmniCore V250XT, rev 04 or later</i>	3HAC074000-008	
<i>Application manual - Scalable I/O</i>	3HAC070208-001	

#### Removing the digital base (option)

##### Preparations

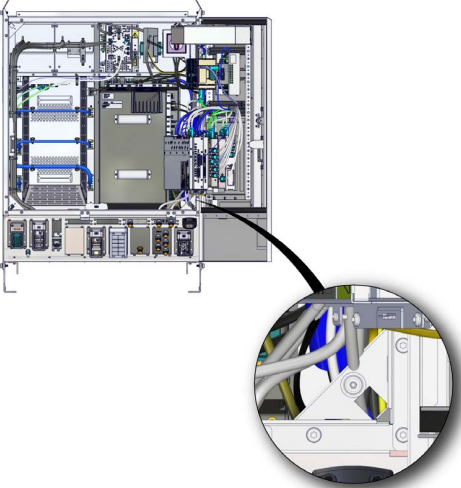
	Action	Note/Illustration
1	 <b>DANGER</b> Before doing any work inside the cabinet, disconnect the mains power. For more information, see <a href="#">Electrical safety on page 29</a> .	
2	Open the door.	<a href="#">Opening the door on page 188</a> .
3	 <b>ELECTROSTATIC DISCHARGE (ESD)</b> The unit is sensitive to ESD. Before handling the unit read the safety information in section <a href="#">The unit is sensitive to ESD on page 45</a> .	Location of wrist strap button:  xx2200001817

#### Removing the digital base (option)

	Action	Note/Illustration
1	Disconnect all connectors from the unit to be replaced.	

*Continues on next page*

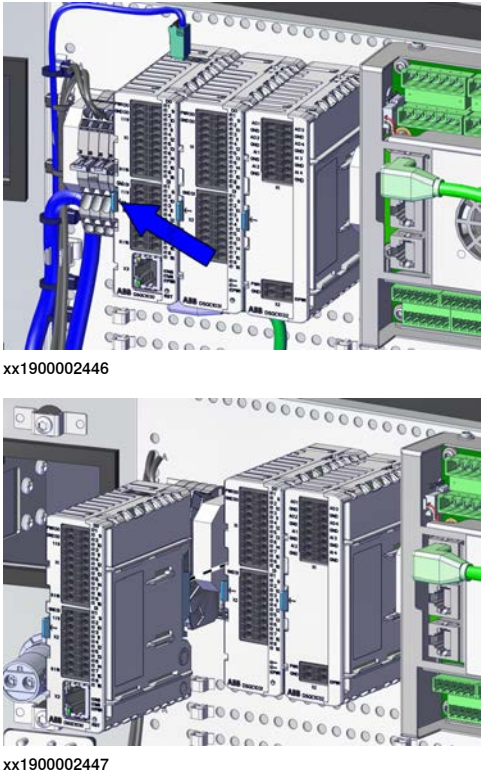
	Action	Note/Illustration
2	Push the buckle of the digital base slightly and take out the digital base.	 <p>xx1900002446</p> <p>xx1900002447</p>

Refitting the digital base (option)

Refitting the digital base (option)



	Action	Note/Illustration
1	 <p><b>DANGER</b></p> <p>Before doing any work inside the cabinet, disconnect the mains power. For more information, see <a href="#">Electrical safety on page 29</a>.</p>	

Continues on next page

## 5 Repair

### 5.2.6 Replacing the scalable I/O unit

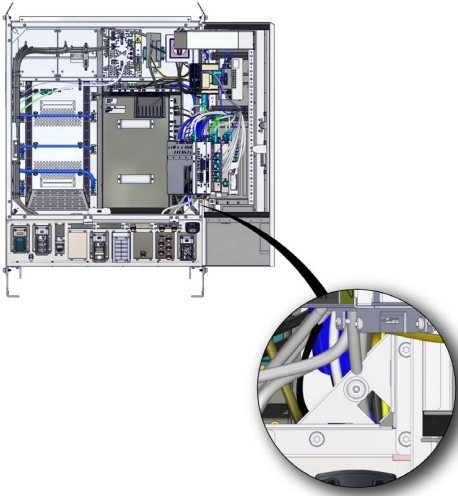
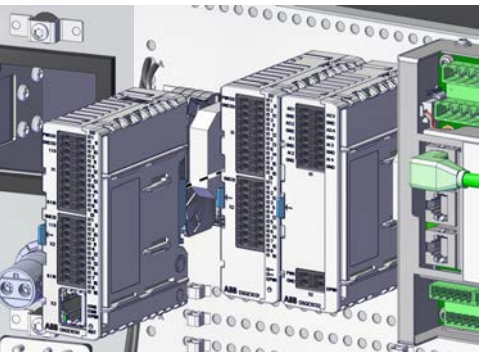
Continued

	Action	Note/Illustration
2	<p> <b>ELECTROSTATIC DISCHARGE (ESD)</b></p> <p>The unit is sensitive to ESD. Before handling the unit read the safety information in section <a href="#">The unit is sensitive to ESD on page 45</a>.</p>	<p>Location of wrist strap button:</p>  <p>xx2200001817</p>
3	<p>Push the digital base into the bracket until you hear a clear clicking sound.</p>	 <p>xx1900002447</p>
4	<p>Connect the adapter cable to the digital base.</p> <ul style="list-style-type: none"> <li>• K5.1.X5/K3.1.X5 - A2.X4/K4.X7</li> </ul> <p> <b>Note</b></p> <p>If the Ethernet extension switch is installed, connect and disconnect the connector K5.1.X5/K3.1.X5 to/from K4.X7.</p> <p>If the Ethernet extension switch is not installed, connect and disconnect the connector K5.1.X5/K3.1.X5 to/from A2.X4.</p> <ul style="list-style-type: none"> <li>• K5.1.X4 - A2.X3</li> <li>• The harness connected to I/O unit by customer</li> </ul>	

Concluding procedure

	Action	Note/Illustration
1	Close the door.	<a href="#">Closing the door on page 189</a> .

Continues on next page

	Action	Note/Illustration
2	Perform the function tests to verify that the safety features work properly, see <a href="#">Function tests on page 177</a> .	

## 5 Repair

### 5.2.7 Replacing the safety digital base device

### 5.2.7 Replacing the safety digital base device

#### Location

The illustration shows the location of the safety digital base device in the controller.

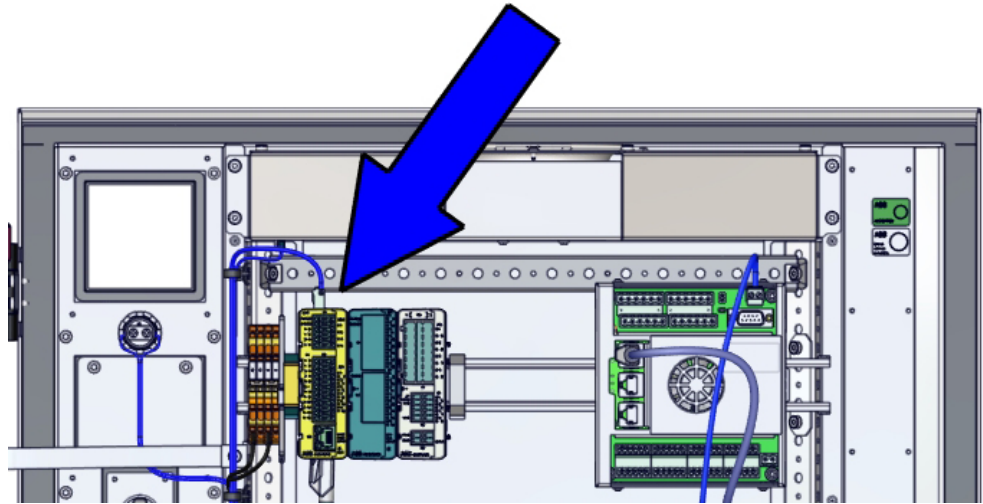

xx2300001819

#### Required spare parts



#### Note

The spare part numbers that are listed in the table can be out of date. See the latest spare parts of the OmniCore V250XT Type B via myABB Business Portal, [www.abb.com/myABB](http://www.abb.com/myABB).

Spare part	Article number	Note
Safe I/O base unit	3HAC062908-001	DSQC1042
Connectors Safety I/O	3HAC069538-001	

#### Required tools and equipment

Equipment	Article number	Note
Standard toolkit	-	Content is defined in section <a href="#">Standard toolkit for controller on page 436</a> .
ESD protective wrist band	-	



#### Required documents

Document	Article number	Note
<i>Circuit diagram - OmniCore V250XT</i> , rev 04 or later	3HAC074000-008	

*Continues on next page*

Removing the safety digital base device

Preparations

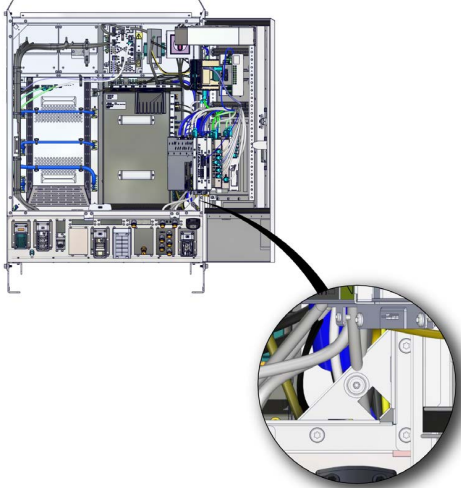
	Action	Note/Illustration
1	 <b>DANGER</b> Before doing any work inside the cabinet, disconnect the mains power. For more information, see <a href="#">Electrical safety on page 29</a> .	
2	Open the door.	<a href="#">Opening the door on page 188</a> .
3	 <b>ELECTROSTATIC DISCHARGE (ESD)</b> The unit is sensitive to ESD. Before handling the unit read the safety information in section <a href="#">The unit is sensitive to ESD on page 45</a> .	Location of wrist strap button:  xx2200001817

Removing the safety digital base device

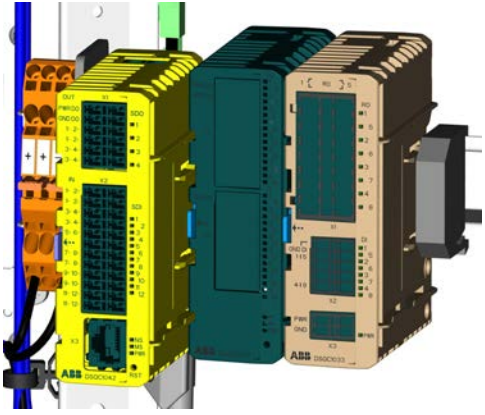
	Action	Note/Illustration
1	Disconnect all connectors from the unit to be replaced.	
2	Push the buckle of the digital base slightly and take out the digital base.	 xx2200001972

Continues on next page





## 5 Repair

### 5.2.7 Replacing the safety digital base device

*Continued*

#### Refitting the safety digital base device

#### Refitting the safety digital base device

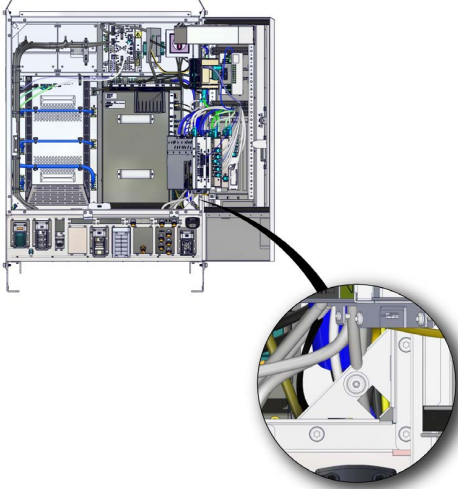
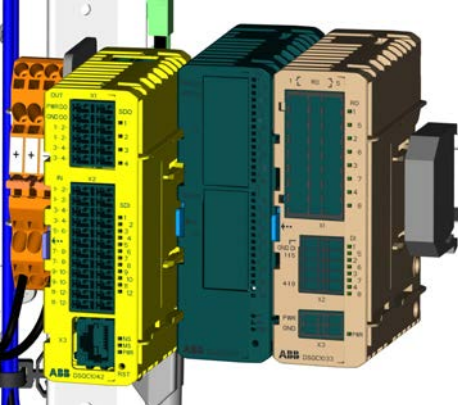
	Action	Note/Illustration
1	 <p><b>DANGER</b></p> <p>Before doing any work inside the cabinet, disconnect the mains power. For more information, see <a href="#">Electrical safety on page 29</a>.</p>	
2	 <p><b>ELECTROSTATIC DISCHARGE (ESD)</b></p> <p>The unit is sensitive to ESD. Before handling the unit read the safety information in section <a href="#">The unit is sensitive to ESD on page 45</a>.</p>	<p>Location of wrist strap button:</p>  <p>xx2200001817</p>
3	<p>Push the digital base into the bracket until you hear a clear clicking sound.</p>	 <p>xx2200001972</p>
4	<p>Reconnect any connectors disconnected at removal.</p>	

#### Concluding procedure

	Action	Note/Illustration
1	<p>Close the door.</p>	<p><a href="#">Closing the door on page 189</a>.</p>

*Continues on next page*



	Action	Note/Illustration
2	Perform the function tests to verify that the safety features work properly, see <a href="#">Function tests on page 177</a> .	

## 5 Repair

### 5.2.8 Replacing the main computer

### 5.2.8 Replacing the main computer

#### Location

The illustration shows the location of the main computer in the controller.

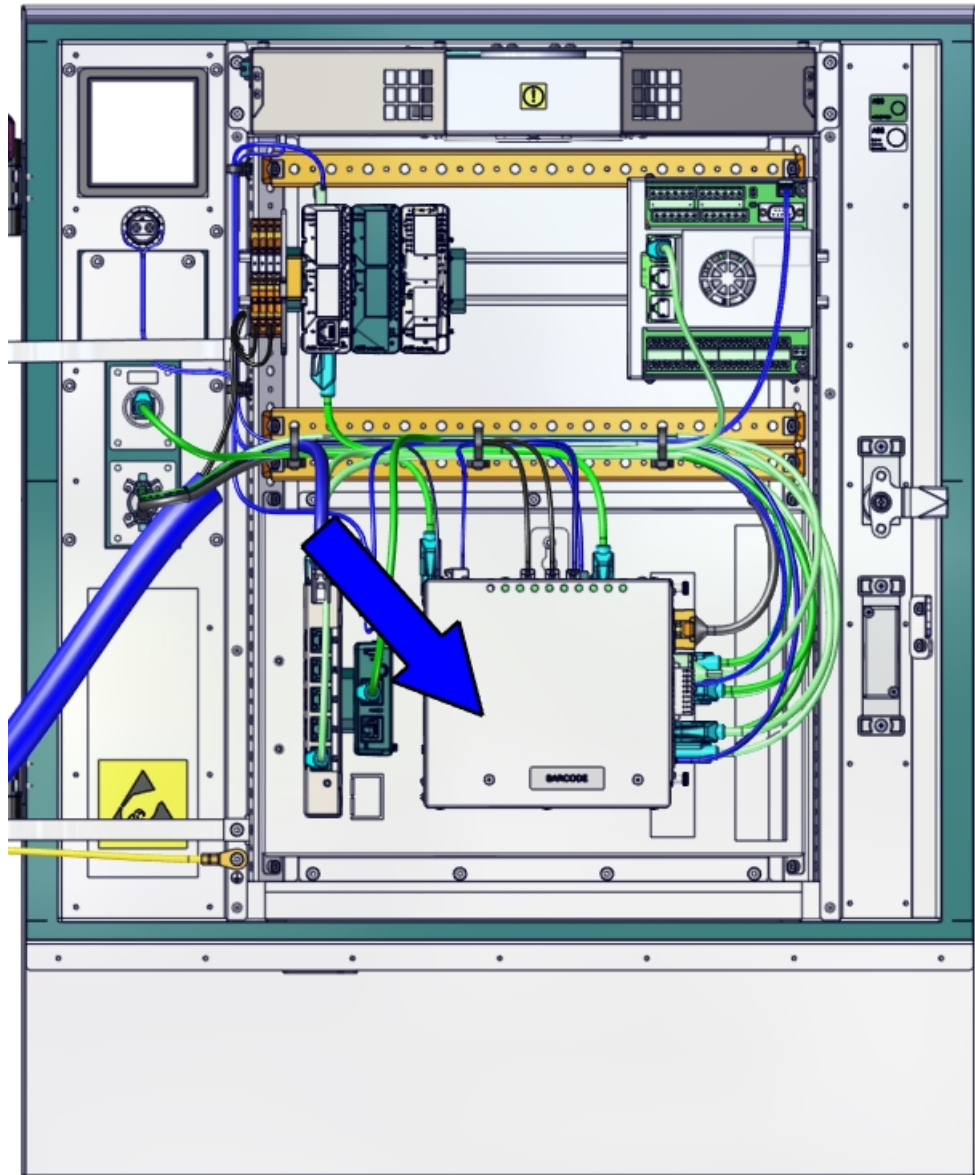

xx2300001837

#### Required spare parts



#### Note

The spare part numbers that are listed in the table can be out of date. See the latest spare parts of the OmniCore V250XT Type B via myABB Business Portal, [www.abb.com/myABB](http://www.abb.com/myABB).

*Continues on next page*

Spare part	Article number	Note
Main computer Standard	3HAC085504-001	DSQC1095

**Required tools and equipment**



Equipment	Article number	Note
Standard toolkit	-	Content is defined in section <a href="#">Standard toolkit for controller on page 436</a> .
ESD protective wrist band	-	

**Required documents**

Document	Article number	Note
<i>Circuit diagram - OmniCore V250XT, rev 04 or later</i>	3HAC074000-008	

**Removing the main computer assembly**

**Preparations**

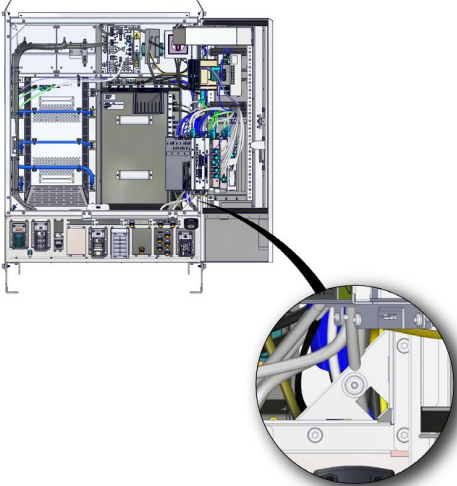
Action	Note/Illustration
<p>1</p>  <p><b>DANGER</b></p> <p>Before doing any work inside the cabinet, disconnect the mains power. For more information, see <a href="#">Electrical safety on page 29</a>.</p>	
<p>2</p> <p>Open the door.</p>	<p><a href="#">Opening the door on page 188</a>.</p>
<p>3</p>  <p><b>ELECTROSTATIC DISCHARGE (ESD)</b></p> <p>The unit is sensitive to ESD. Before handling the unit read the safety information in section <a href="#">The unit is sensitive to ESD on page 45</a>.</p>	<p>Location of wrist strap button:</p>  <p>xx2200001817</p>

Continues on next page

## 5 Repair

### 5.2.8 Replacing the main computer

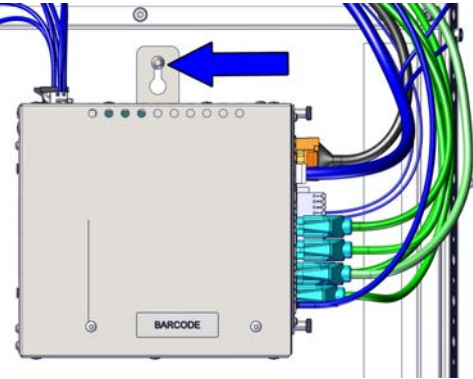

*Continued*

#### Removing the main computer assembly

	Action	Note/Illustration
1	Remove any cable ties.	
2	Disconnect all connectors from the unit to be replaced.	
3	Remove the main computer assembly from the mounting plate.   <b>ELECTROSTATIC DISCHARGE (ESD)</b>  The unit must be maintained in an ESD-safe environment.	  xx2200001089

#### Refitting the main computer assembly

#### Refitting the main computer assembly

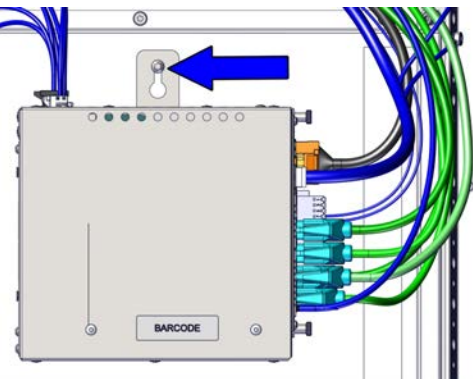
	Action	Note/Illustration
1	 <b>DANGER</b>  Before doing any work inside the cabinet, disconnect the mains power. For more information, see <a href="#">Electrical safety on page 29</a> .	
2	 <b>ELECTROSTATIC DISCHARGE (ESD)</b>  The unit must be maintained in an ESD-safe environment.	
3	Refit the assembly onto the mounting plate and tighten the screw.	  xx2200001089
4	Reconnect any connectors disconnected at removal.	

*Continues on next page*

	Action	Note/Illustration
5	Apply cable ties and suitable cable protection to ensure that the cables may not be damaged by the door.	

## Concluding procedure

	Action	Note/Illustration
1	Close the door.	<a href="#">Closing the door on page 189.</a>
2	Restore the hardware settings.	<a href="#">Restoring the hardware settings on page 241.</a>
3	Perform the function tests to verify that the safety features work properly, see <a href="#">Function tests on page 177.</a>	

## Restoring the hardware settings

The controller hardware settings include information such as controller type and serial number. When the main computer has been replaced, the serial number must be restored before any software can be installed, or any licences can be imported.

**Note**

When replacing the computer and logic unit, both the serial number and licences are lost. The serial number must be restored as described below. Licences however, can either be restored automatically when the RobotWare system is installed, or manually through **Manage Licences** in RobotWare Installation Utilities.

	Action	Note/Illustration
1	Download the hardware information file (hwsettings.rsf) from MyABB, or from a previous system backup.	
2	Access the RobotWare Installation Utilities.	 xx1900000110
3	Tap <b>Advanced</b> , and then <b>Restore Hardware Settings</b> .	
4	The <b>Restore Hardware Settings</b> window is displayed. Follow the instructions and tap <b>Next</b> to proceed.	

Continues on next page

## 5 Repair

### 5.2.8 Replacing the main computer

*Continued*

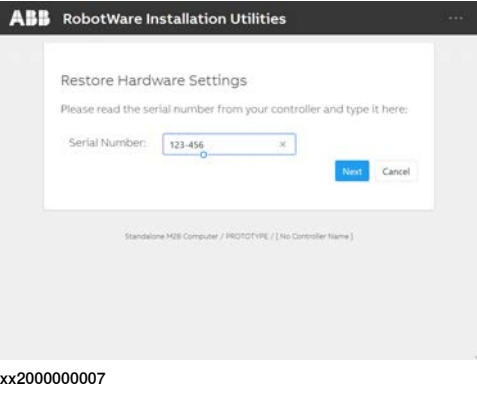
	Action	Note/Illustration
5	Carefully read the information and then check all boxes to confirm that you agree with the ABB conditions. Tap <b>Next</b> to proceed.	
6	<p>Enter the controller serial number in field <b>Serial Number</b>. Tap <b>Next</b>.</p> <p> <b>Note</b></p> <p>The serial number is found on the silver label.</p>	 <p>ABB RobotWare Installation Utilities</p> <p>Restore Hardware Settings</p> <p>Please read the serial number from your controller and type it here:</p> <p>Serial Number: <input type="text" value="123-456"/> <input type="button" value="X"/> <input type="button" value="Next"/> <input type="button" value="Cancel"/></p> <p>Standalone M2B Computer / PROTOFRAME / [No Controller Name]</p> <p>xx2000000007</p>
7	Tap <b>Browse</b> to open the hardware information file from its location. The restoration of the serial number is completed.	The system compares the downloaded file and the manually entered serial number to ensure that there is a match.

### 5.2.9 Replacing the main computer battery

**Location**

The illustration shows the location of the main computer in the controller.

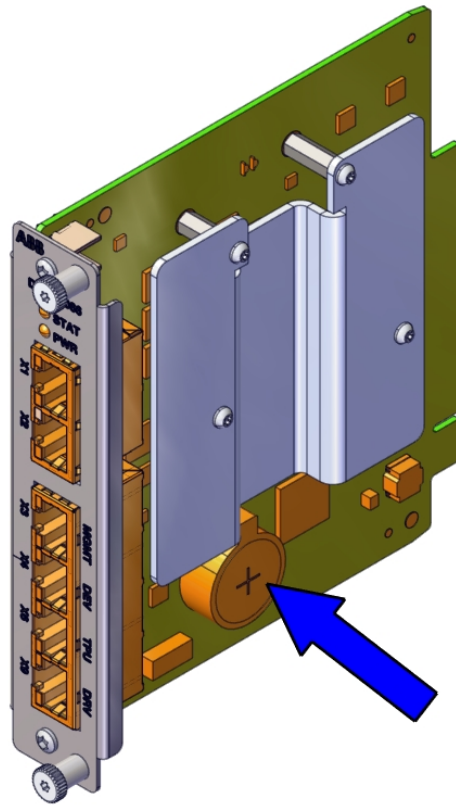

xx2300001945

**Required spare parts**



**Note**

This is a standard battery. It is not a registered spare part.

Spare part	Article number	Note
Standard Coin Cell Battery	N/A	CR2032

**Required tools and equipment**

Equipment	Article number	Note
Standard toolkit	-	Content is defined in section <a href="#">Standard toolkit for controller on page 436</a> .
ESD protective wrist band	-	

*Continues on next page*

## 5 Repair

### 5.2.9 Replacing the main computer battery



*Continued*

#### Required documents

Document	Article number	Note
Circuit diagram - OmniCore V250XT, rev 04 or later	3HAC074000-008	

#### Removing the main computer battery

##### Preparations

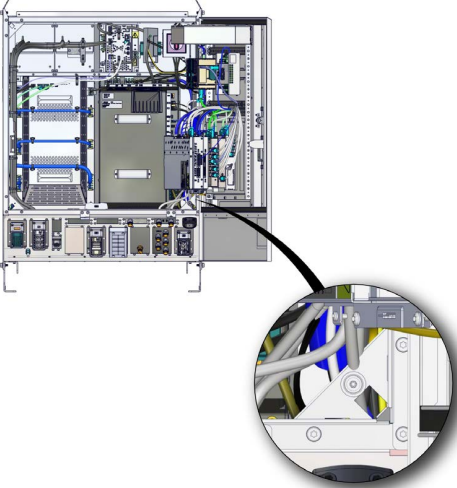
	Action	Note/Illustration
1	 <b>DANGER</b> Before doing any work inside the cabinet, disconnect the mains power. For more information, see <a href="#">Electrical safety on page 29</a> .	
2	Open the door.	<a href="#">Opening the door on page 188</a> .
3	 <b>ELECTROSTATIC DISCHARGE (ESD)</b> The unit is sensitive to ESD. Before handling the unit read the safety information in section <a href="#">The unit is sensitive to ESD on page 45</a> .	Location of wrist strap button:  xx2200001817

*Continues on next page*

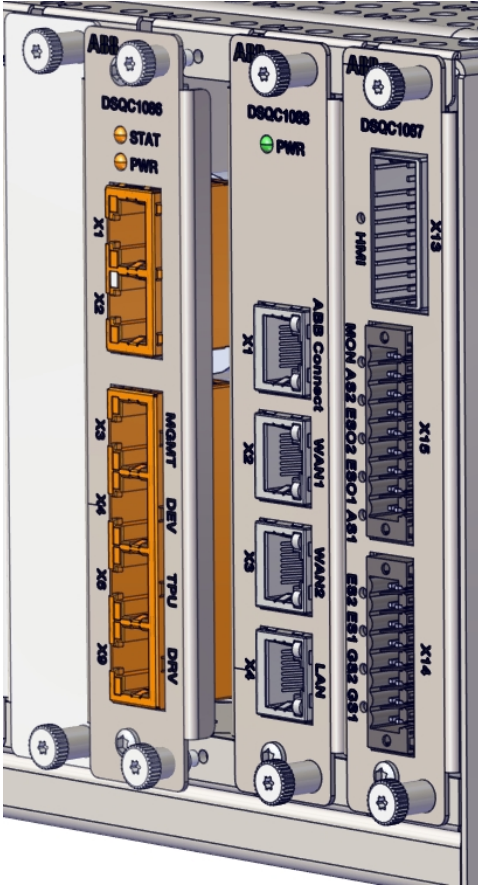

Removing the main computer battery

Action	Note/Illustration
<p>1 Loosen the screws that hold the processor board unit, DSQC1086.</p>	 <p>xx230000941</p>
<p>2 Remove the processor board unit from the slot in the main computer assembly.</p>	

Continues on next page

## 5 Repair

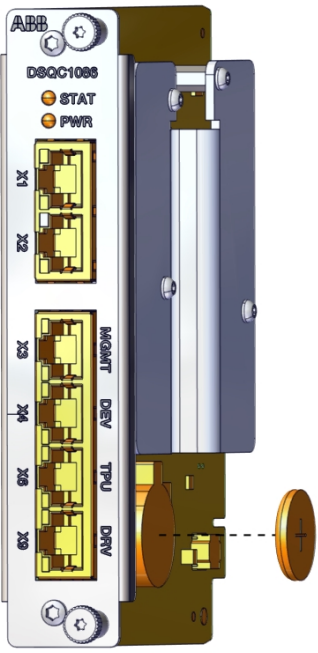

### 5.2.9 Replacing the main computer battery

Continued

	Action	Note/Illustration
3	Remove the battery.	 <p>xx2300000942</p>

### Refitting the main computer battery

#### Preparations

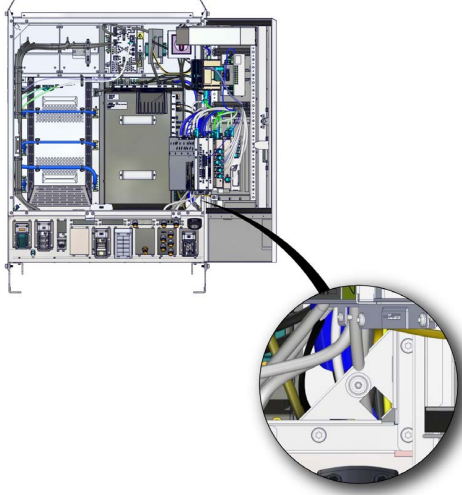
	Action	Note/Illustration
1	 <p><b>DANGER</b></p> <p>Before doing any work inside the cabinet, disconnect the mains power. For more information, see <a href="#">Electrical safety on page 29</a>.</p>	
2	 <p><b>ELECTROSTATIC DISCHARGE (ESD)</b></p> <p>The unit is sensitive to ESD. Before handling the unit read the safety information in section <a href="#">The unit is sensitive to ESD on page 45</a>.</p>	 <p>xx2200001817</p>

Continues on next page

Refitting the battery

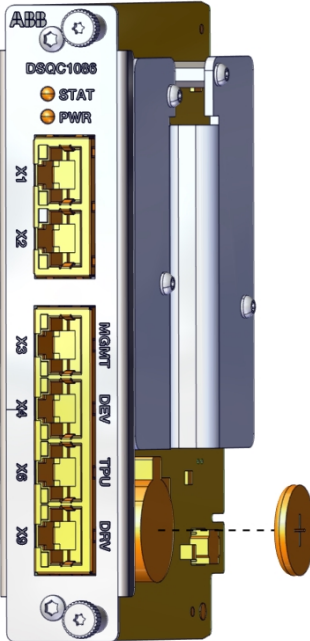
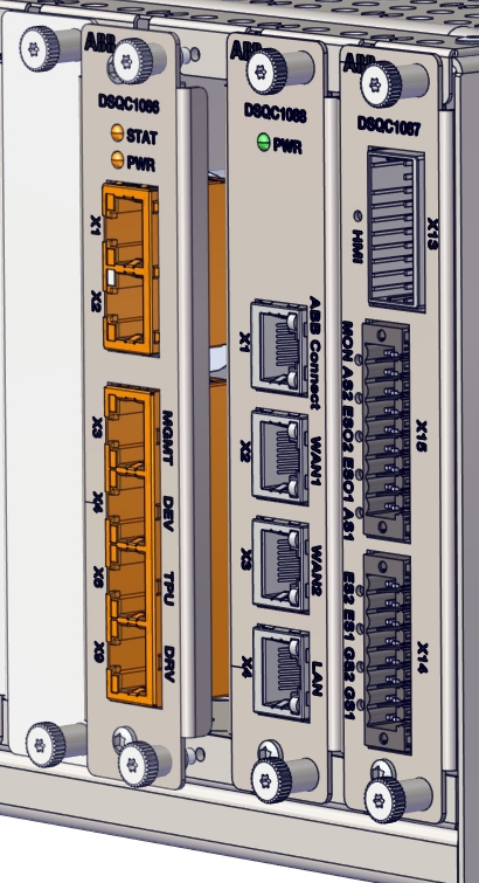
	Action	Note/Illustration
1	Insert the battery into the slot in the processor board unit.	 <p>xx230000942</p>
2	Insert the processor board unit into the slot in the main computer assembly.	 <p>xx230000941</p>

Continues on next page

## 5 Repair

---

### 5.2.9 Replacing the main computer battery

*Continued*

	Action	Note/Illustration
3	Secure the screws that hold the processor board unit.	

Concluding procedure

	Action	Note/Illustration
1	Close the door.	<a href="#">Closing the door on page 189.</a>
2	Perform the function tests to verify that the safety features work properly, see <a href="#">Function tests on page 177.</a>	

### 5.2.10 Replacing the power unit

#### Location

The illustration shows the location of the power unit in the controller.

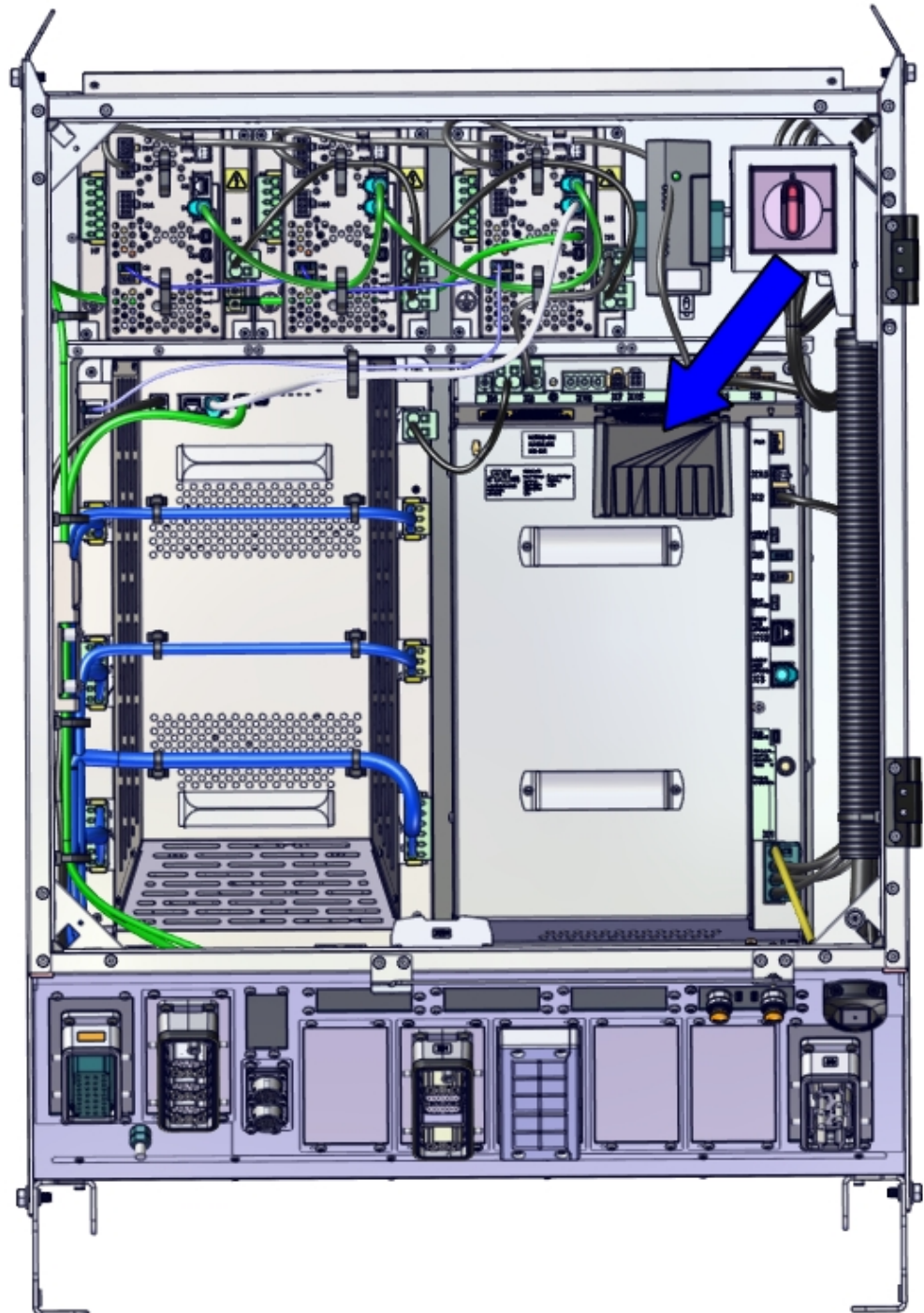

xx2300001838

*Continues on next page*

## 5 Repair

### 5.2.10 Replacing the power unit

Continued



#### WARNING

Do not touch the power unit when the **DC-BUS High Voltage LED** is on.  
There is residual voltage in the power unit even if the main switch is in the OFF position.

#### Required spare parts



#### Note

The spare part numbers that are listed in the table can be out of date. See the latest spare parts of the OmniCore V250XT Type B via myABB Business Portal, [www.abb.com/myABB](http://www.abb.com/myABB).

Spare part	Article number	Note
Power unit	3HAC063632-001	DSQC3070 HV 3x380-480V
Power unit	3HAC062699-001	DSQC3069 LV 3x380-480V

#### Required tools and equipment

Equipment	Article number	Note
Standard toolkit	-	Content is defined in section <a href="#">Standard toolkit for controller on page 436</a> .
ESD protective wrist band	-	

#### Required documents

Document	Article number	Note
<i>Circuit diagram - OmniCore V250XT</i> , rev 04 or later	3HAC074000-008	

#### Removing the power unit



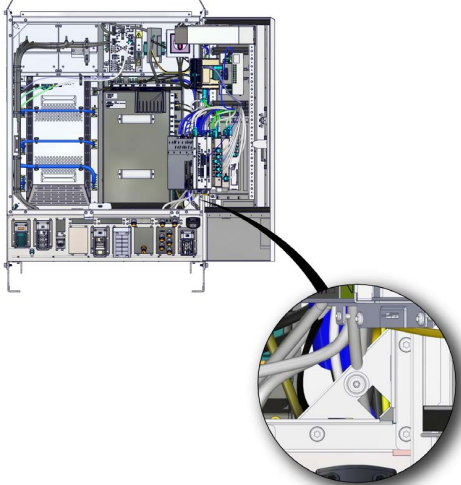

##### Preparations

	Action	Note/Illustration
1	 <b>DANGER</b> Before doing any work inside the cabinet, disconnect the mains power. For more information, see <a href="#">Electrical safety on page 29</a> .	
2	Open the door.	<a href="#">Opening the door on page 188</a> .

Continues on next page

	Action	Note/Illustration
3	<p> <b>ELECTROSTATIC DISCHARGE (ESD)</b></p> <p>The unit is sensitive to ESD. Before handling the unit read the safety information in section <i>The unit is sensitive to ESD</i> on page 45.</p>	<p>Location of wrist strap button:</p>  <p>xx2200001817</p>

Removing the power unit

	Action	Note/Illustration
1	<p>Disconnect all connectors from the unit to be replaced.</p>	
2	<p>Remove the screws and pull the power unit out from the two guiding pins on the mounting plate.</p> <p> <b>CAUTION</b></p> <p>Only the sheet metal on the power unit can be used for holding. Do not touch the connectors or the filter on the power unit.</p> <p> <b>CAUTION</b></p> <p>The weight of the power unit is 13 kg. Use protective gloves when lifting this unit.</p> <p> <b>CAUTION</b></p> <p>The cabling is sensitive to mechanical damage. Handle it with care to avoid damage to the cabling or the connector, avoid any kind of tilt or skew.</p>	 <p>xx2100000322</p>

Continues on next page





## 5 Repair

### 5.2.10 Replacing the power unit

Continued

#### Refitting the power unit

#### Refitting the power unit

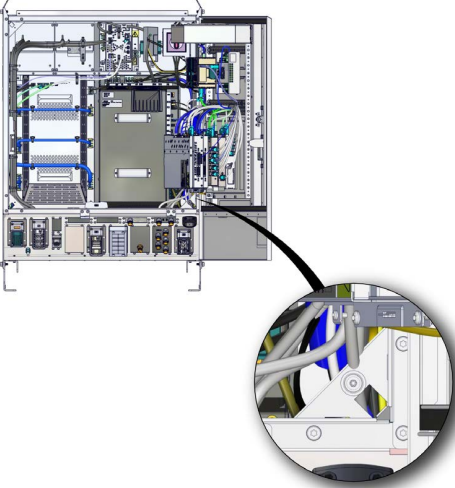
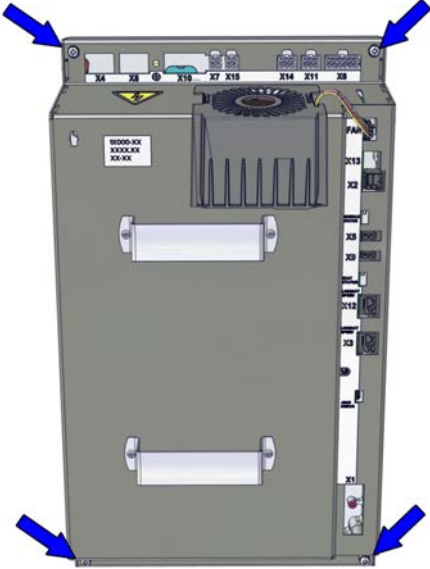
	Action	Note/Illustration
1	 <p><b>DANGER</b></p> <p>Before doing any work inside the cabinet, disconnect the mains power. For more information, see <a href="#">Electrical safety on page 29</a>.</p>	
2	 <p><b>ELECTROSTATIC DISCHARGE (ESD)</b></p> <p>The unit is sensitive to ESD. Before handling the unit read the safety information in section <a href="#">The unit is sensitive to ESD on page 45</a>.</p>	<p>Location of wrist strap button:</p>  <p>xx2200001817</p>
3	<p>Position the power unit on the lower guiding pin on the mounting plate, and then tip the unit upwards against the upper guiding pin. Secure the screws.</p>	<p>Screws: Torx pan head screw M4x8 (4 pcs) Tightening torque: 2 Nm</p>  <p>xx2100000322</p>

Continues on next page



	Action	Note/Illustration
4	Reconnect any connectors disconnected at removal.	

## Concluding procedure

	Action	Note/Illustration
1	Close the door.	<i>Closing the door on page 189.</i>
2	Perform the function tests to verify that the safety features work properly, see <i>Function tests on page 177.</i>	

## 5 Repair

### 5.2.11 Replacing the HVLP power unit (DSQC3072)

### 5.2.11 Replacing the HVLP power unit (DSQC3072)

#### Location

The illustration shows the location of the power unit in the controller.

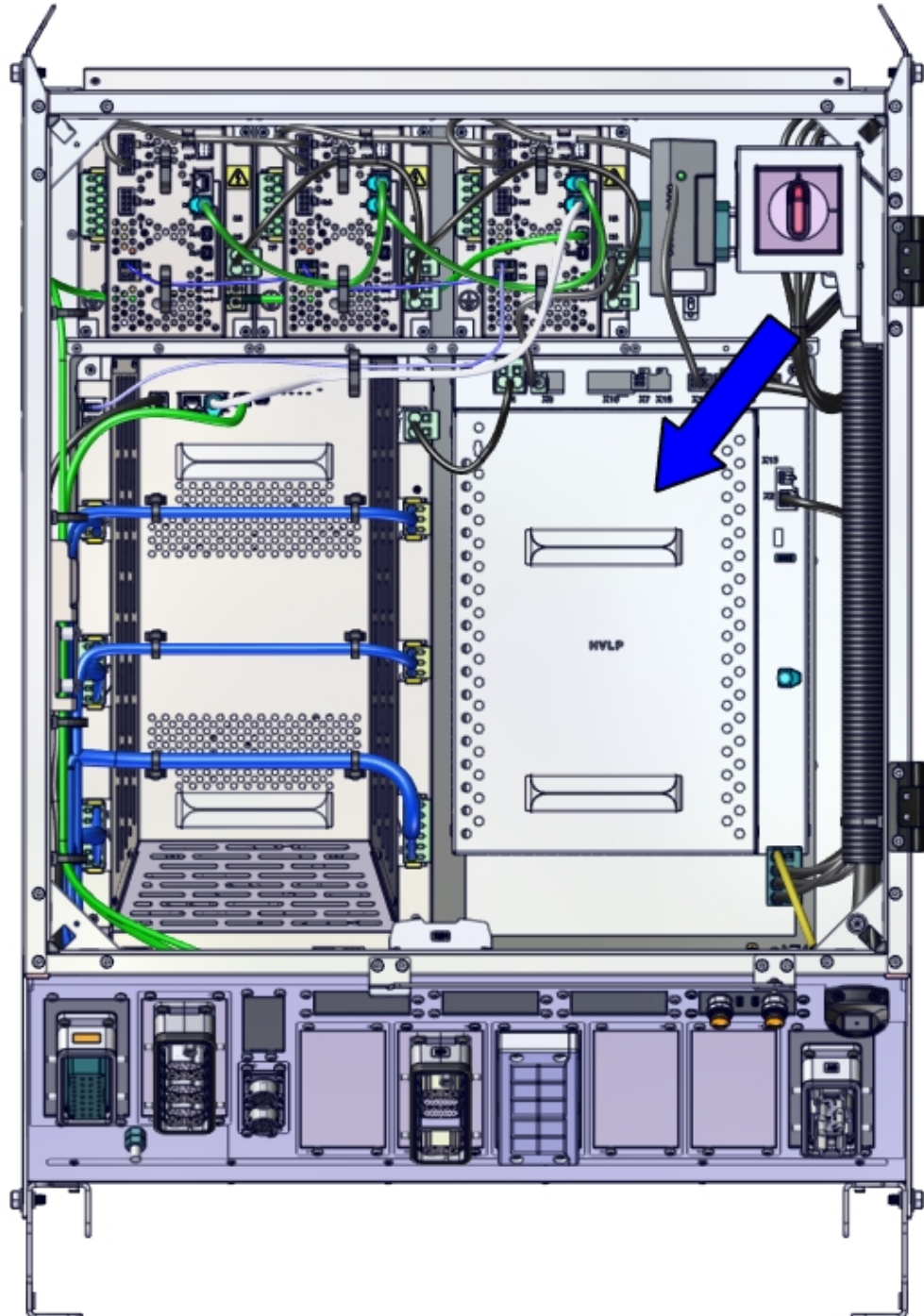

xx2300001991

*Continues on next page*

## Required spare parts



## Note

The spare part numbers that are listed in the table can be out of date. See the latest spare parts of the OmniCore V250XT Type B via myABB Business Portal, [www.abb.com/myABB](http://www.abb.com/myABB).

Spare part	Article number	Note
Power unit	3HAC066498-001	DSQC3072 HVLP

## Required tools and equipment

Equipment	Article number	Note
Standard toolkit	-	Content is defined in section <a href="#">Standard toolkit for controller on page 436</a> .
ESD protective wrist band	-	

## Required documents

Document	Article number	Note
Circuit diagram - OmniCore V250XT, rev 04 or later	3HAC074000-008	

## Removing the power unit

## Preparations

	Action	Note/Illustration
1	 <b>DANGER</b> Before doing any work inside the cabinet, disconnect the mains power. For more information, see <a href="#">Electrical safety on page 29</a> .	
2	Open the door.	<a href="#">Opening the door on page 188</a> .

Continues on next page

## 5 Repair

### 5.2.11 Replacing the HVLP power unit (DSQC3072)

Continued

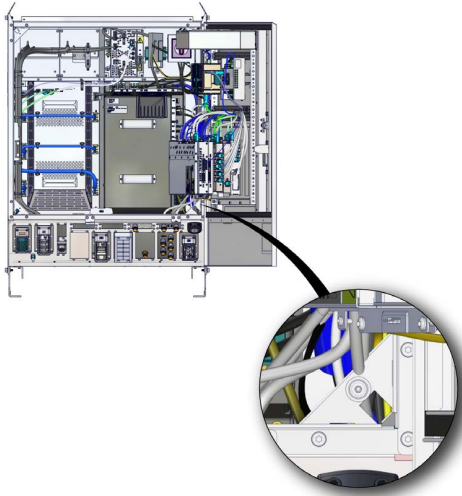
	Action	Note/Illustration
3	 <p><b>ELECTROSTATIC DISCHARGE (ESD)</b></p> <p>The unit is sensitive to ESD. Before handling the unit read the safety information in section <i>The unit is sensitive to ESD on page 45.</i></p>	<p>Location of wrist strap button:</p>  <p>xx2200001817</p>

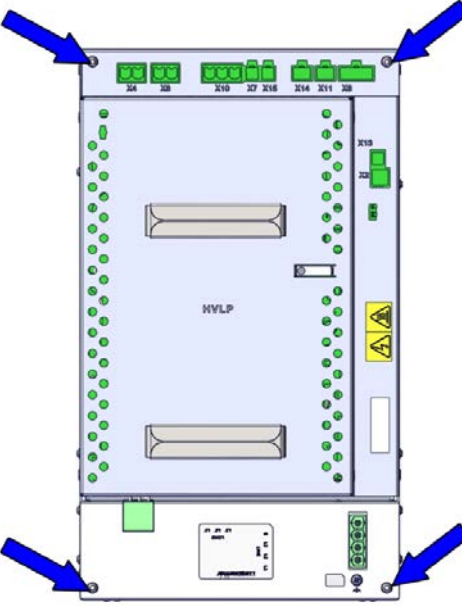

### Removing the power unit

	Action	Note/Illustration
1	<p>Disconnect all connectors from the unit to be replaced.</p>	
2	<p>Remove the screws and pull the power unit out from the two guiding pins on the mounting plate.</p> <p> <b>CAUTION</b></p> <p>Only the sheet metal on the power unit can be used for holding. Do not touch the connectors or the filter on the power unit.</p>	 <p>xx2300001492</p>

Continues on next page

Refitting the power unit

Refitting the power unit

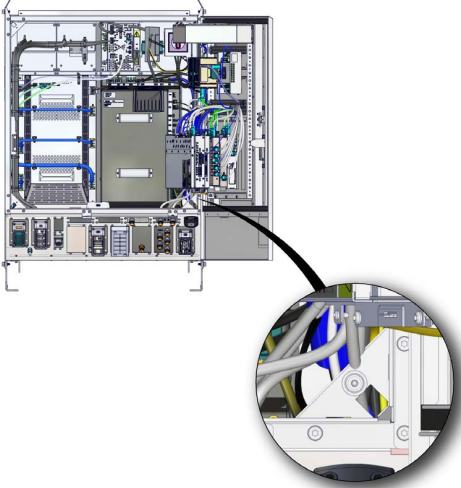
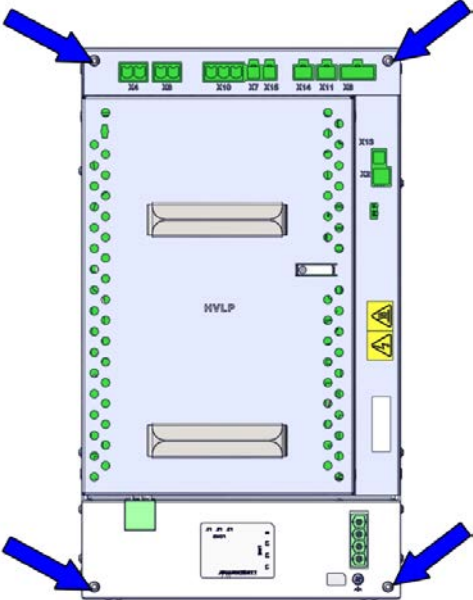
	Action	Note/Illustration
1	 <p><b>DANGER</b></p> <p>Before doing any work inside the cabinet, disconnect the mains power. For more information, see <a href="#">Electrical safety on page 29</a>.</p>	
2	 <p><b>ELECTROSTATIC DISCHARGE (ESD)</b></p> <p>The unit is sensitive to ESD. Before handling the unit read the safety information in section <a href="#">The unit is sensitive to ESD on page 45</a>.</p>	<p>Location of wrist strap button:</p>  <p>xx2200001817</p>
3	<p>Position the power unit on the lower guiding pin on the mounting plate, and then tip the unit upwards against the upper guiding pin. Secure the screws.</p>	<p>Screws: Torx pan head screw M4x8 (4 pcs) Tightening torque: 2 Nm</p>  <p>xx2300001492</p>

Continues on next page

## 5 Repair

---

### 5.2.11 Replacing the HVLP power unit (DSQC3072)

*Continued*

	Action	Note/Illustration
4	Reconnect any connectors disconnected at removal.	

Concluding procedure

	Action	Note/Illustration
1	Close the door.	<a href="#">Closing the door on page 189.</a>
2	Perform the function tests to verify that the safety features work properly, see <a href="#">Function tests on page 177.</a>	

### 5.2.12 Replacing the power supply

#### Location

The illustration shows the location of the power supply in the controller.

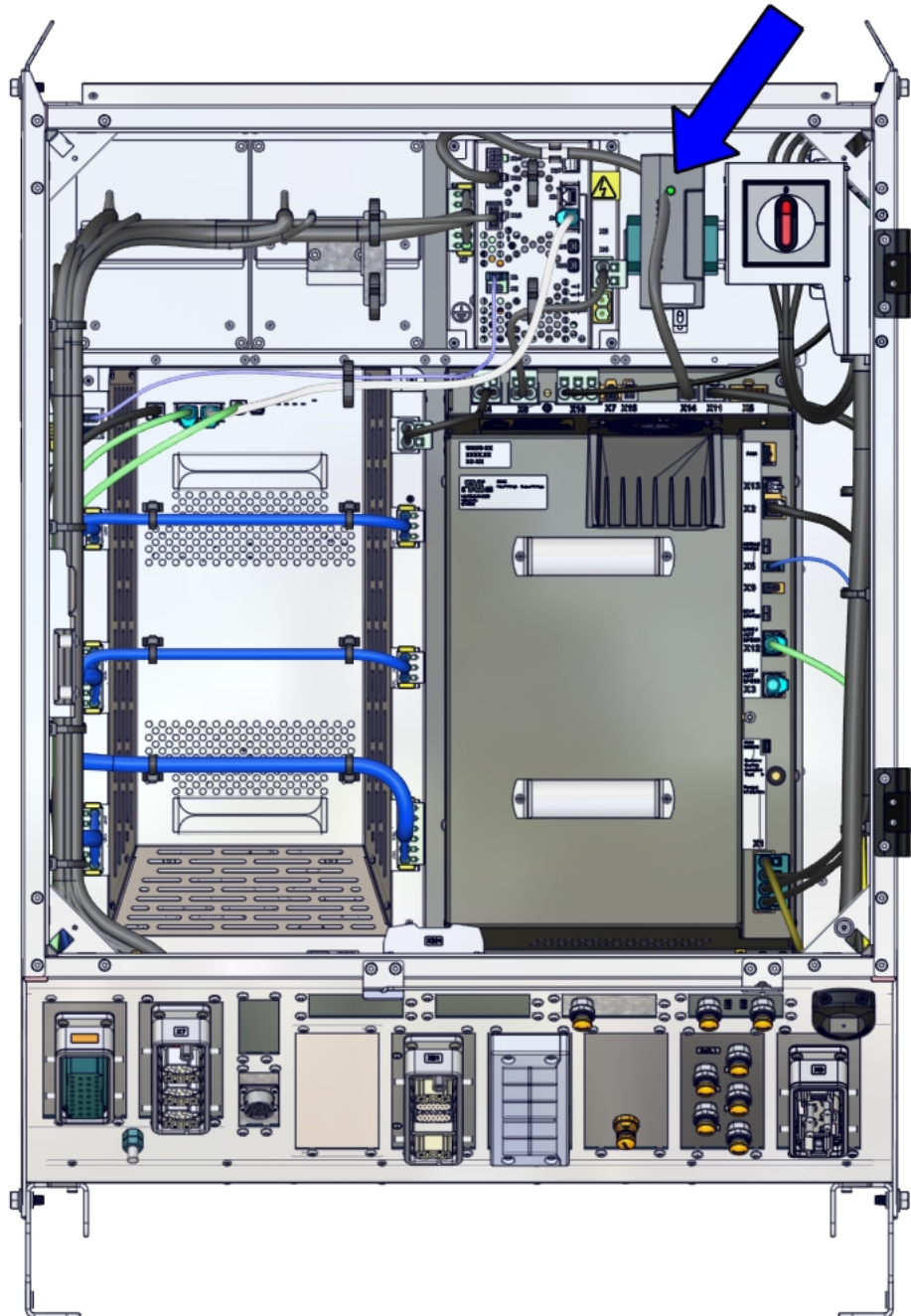

xx2200001473

*Continues on next page*

## 5 Repair

### 5.2.12 Replacing the power supply

Continued



#### WARNING

Do not touch the power supply when the DC OK LED is on.

There is residual voltage in the power supply even if the main switch is in the OFF position.

#### Required spare parts



#### Note

The spare part numbers that are listed in the table can be out of date. See the latest spare parts of the OmniCore V250XT Type B via myABB Business Portal, [www.abb.com/myABB](http://www.abb.com/myABB).

Spare part	Article number	Note
DSQC 609 power supply	3HAC14178-1	DSQC 609
DSQC 634 power supply	3HAC13398-2	DSQC 634
Harness PSU 24V	3HAC082083-001	DSQC 609 and DSQC 634
Harness PSU	3HAC082508-001	DSQC 609 and DSQC 634
End clamp	3HAB7983-1	

#### Required tools and equipment

Equipment	Article number	Note
Standard toolkit	-	Content is defined in section <a href="#">Standard toolkit for controller on page 436</a> .
ESD protective wrist band	-	

#### Required documents

Document	Article number	Note
<i>Circuit diagram - OmniCore V250XT</i> , rev 04 or later	3HAC074000-008	

#### Removing the DSQC 609 power supply

##### Preparations

	Action	Note/Illustration
1	 <b>DANGER</b> Before doing any work inside the cabinet, disconnect the mains power. For more information, see <a href="#">Electrical safety on page 29</a> .	
2	Open the door.	<a href="#">Opening the door on page 188</a> .

Continues on next page

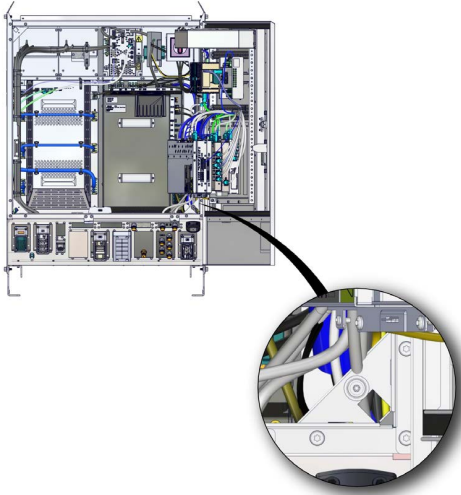

	Action	Note/Illustration
3	<p> <b>ELECTROSTATIC DISCHARGE (ESD)</b></p> <p>The unit is sensitive to ESD. Before handling the unit read the safety information in section <i>The unit is sensitive to ESD on page 45.</i></p>	<p>Location of wrist strap button:</p>  <p>xx2200001817</p>

Removing the power supply

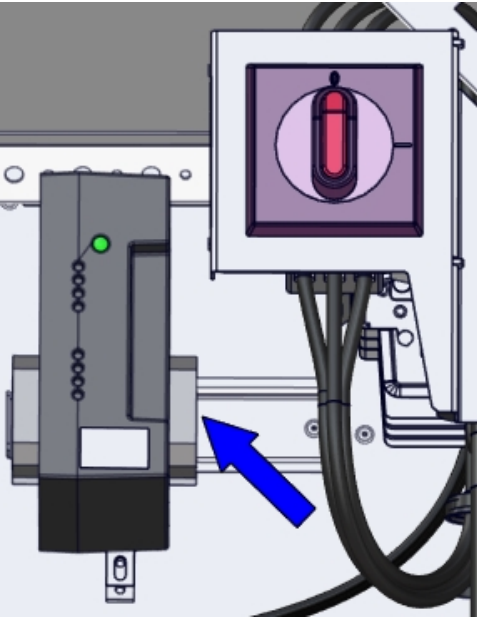
	Action	Note/Illustration
1	<p>Remove the end clamp besides the power supply with a screwdriver.</p>	 <p>xx2200002009</p>

Continues on next page

## 5 Repair

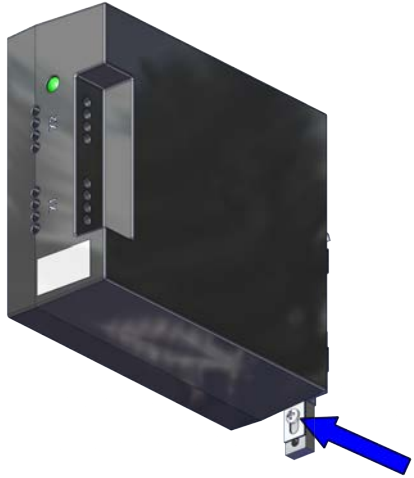

### 5.2.12 Replacing the power supply

Continued

	Action	Note/Illustration
2	Disconnect all connectors from the unit to be replaced.	 <p data-bbox="922 810 1034 833">xx1900001908</p>
3	Remove the screw and the power supply.	

### Refitting the DSQC 609 power supply

Refitting the power supply

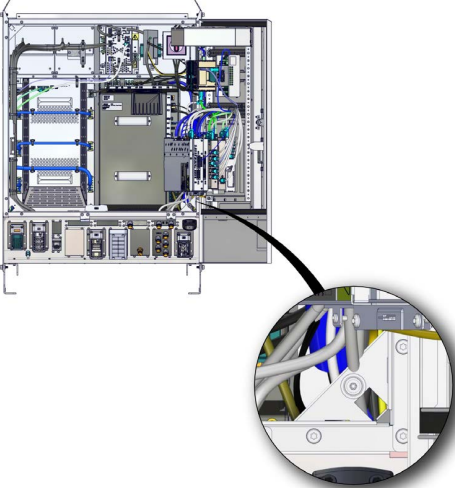
	Action	Note/Illustration
1	 <p data-bbox="563 1077 671 1106"><b>DANGER</b></p> <p data-bbox="472 1137 916 1249">Before doing any work inside the cabinet, disconnect the mains power. For more information, see <a href="#">Electrical safety on page 29</a>.</p>	
2	 <p data-bbox="563 1305 916 1361"><b>ELECTROSTATIC DISCHARGE (ESD)</b></p> <p data-bbox="472 1379 916 1491">The unit is sensitive to ESD. Before handling the unit read the safety information in section <a href="#">The unit is sensitive to ESD on page 45</a>.</p>	<p data-bbox="927 1283 1257 1312">Location of wrist strap button:</p>  <p data-bbox="922 1823 1034 1845">xx2200001817</p>

Continues on next page

5.2.12 Replacing the power supply  
Continued

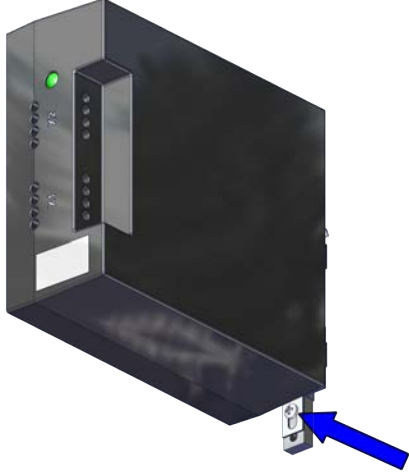
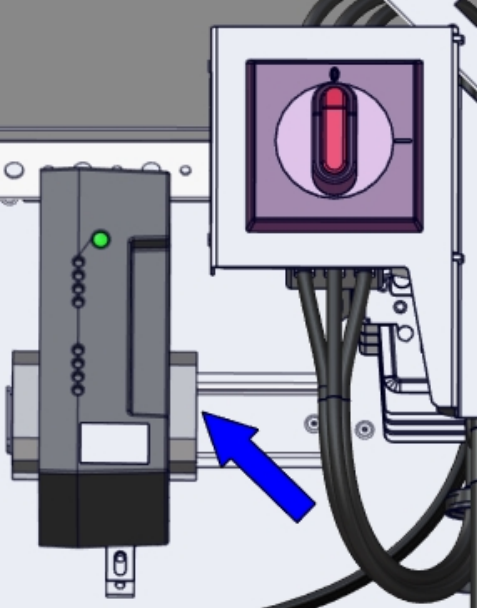
	Action	Note/Illustration
3	Fit the power supply to the bracket and fasten it with screw.	<p>Screws: Cross recessed cheese head screw M4x8 (1 pcs) Tightening torque: 1.7 Nm±10%.</p>  <p>xx1900001908</p>
4	Reconnect any connectors disconnected at removal.	
5	Refit the end clamp besides the power supply.	 <p>xx2200002009</p>

Concluding procedure

	Action	Note/Illustration
1	Close the door.	<a href="#">Closing the door on page 189.</a>
2	Perform the function tests to verify that the safety features work properly, see <a href="#">Function tests on page 177.</a>	

Continues on next page



## 5 Repair

### 5.2.12 Replacing the power supply

*Continued*

#### Removing the DSQC 634 power supply

##### Preparations

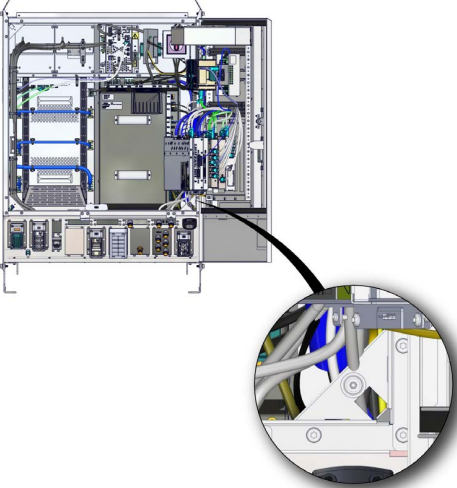
	Action	Note/Illustration
1	 <b>DANGER</b> Before doing any work inside the cabinet, disconnect the mains power. For more information, see <a href="#">Electrical safety on page 29</a> .	
2	Open the door.	<a href="#">Opening the door on page 188</a> .
3	 <b>ELECTROSTATIC DISCHARGE (ESD)</b> The unit is sensitive to ESD. Before handling the unit read the safety information in section <a href="#">The unit is sensitive to ESD on page 45</a> .	Location of wrist strap button:  xx2200001817

##### Removing the power supply

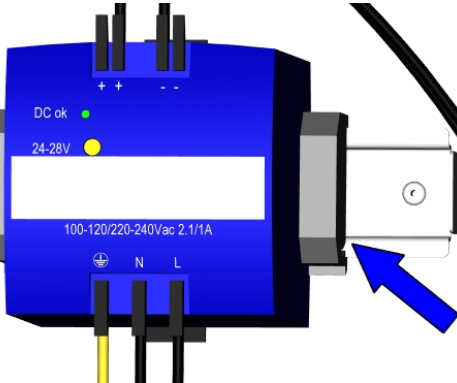
	Action	Note/Illustration
1	Remove the end clamp besides the power supply with a screwdriver.	 xx2200002011

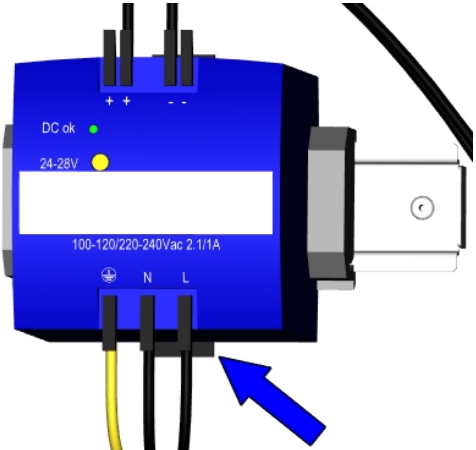

*Continues on next page*

5.2.12 Replacing the power supply  
Continued

	Action	Note/Illustration
2	Disconnect all connectors from the unit to be replaced.	 <p>DC ok 24-28V 100-120/220-240Vac 2.1/1A N L</p> <p>xx2200002012</p>
3	Press the lower buckle to release and remove the power supply.	

Refitting the DSQC 634 power supply

Refitting the power supply

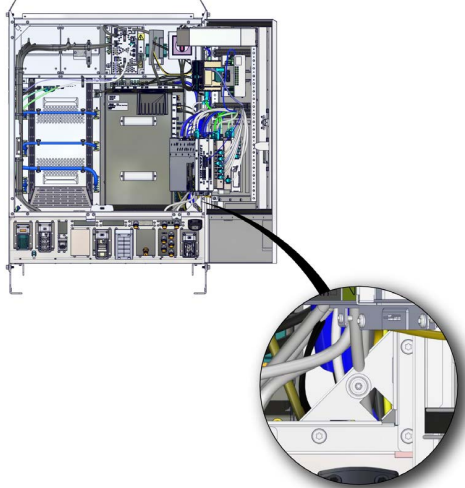
	Action	Note/Illustration
1	 <p><b>DANGER</b></p> <p>Before doing any work inside the cabinet, disconnect the mains power. For more information, see <a href="#">Electrical safety on page 29</a>.</p>	
2	 <p><b>ELECTROSTATIC DISCHARGE (ESD)</b></p> <p>The unit is sensitive to ESD. Before handling the unit read the safety information in section <a href="#">The unit is sensitive to ESD on page 45</a>.</p>	<p>Location of wrist strap button:</p>  <p>xx2200001817</p>

Continues on next page

## 5 Repair

### 5.2.12 Replacing the power supply

*Continued*

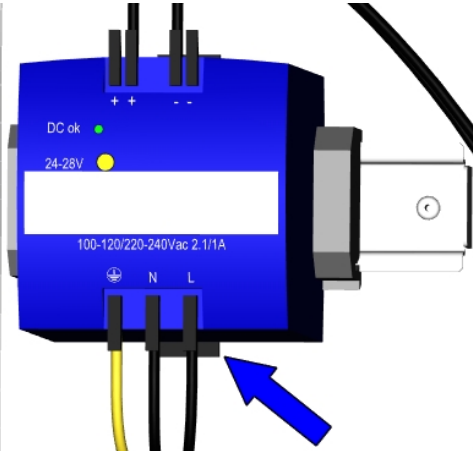
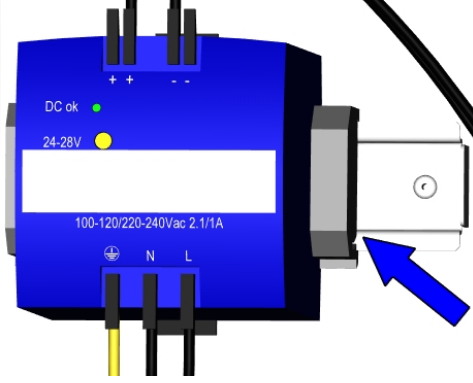
	Action	Note/Illustration
3	Hang the power supply into the bracket and push the lower of it until you hear a clear clicking sound.	 <p>xx2200002012</p>
4	Reconnect any connectors disconnected at removal.	
5	Refit the end clamp besides the power supply.	 <p>xx2200002011</p>

#### Concluding procedure

	Action	Note/Illustration
1	Close the door.	<a href="#">Closing the door on page 189.</a>
2	Perform the function tests to verify that the safety features work properly, see <a href="#">Function tests on page 177.</a>	

### 5.2.13 Replacing the drive unit

#### Location

The illustration shows the location of the drive unit in the controller.

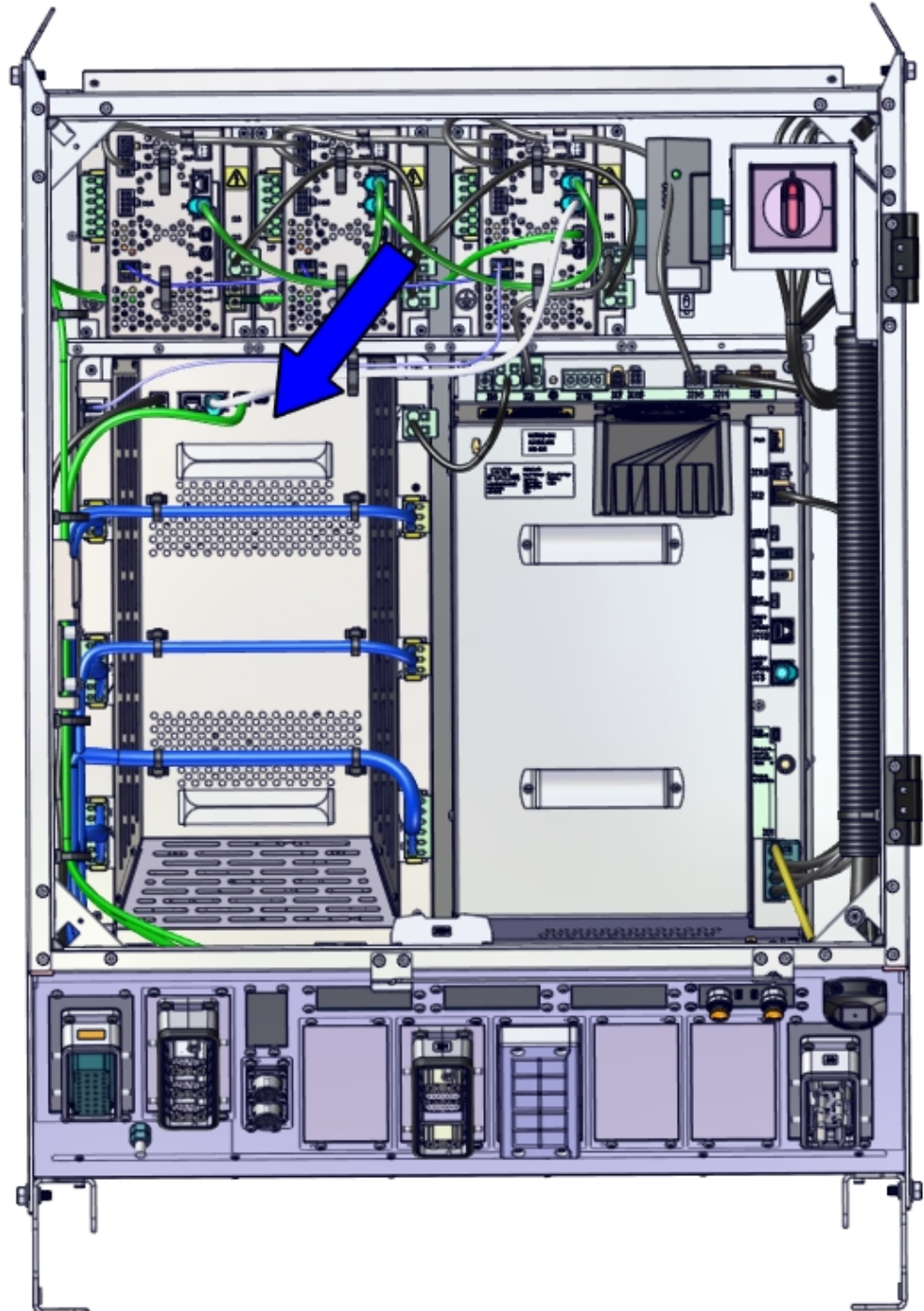

xx2300001839

*Continues on next page*

## 5 Repair

### 5.2.13 Replacing the drive unit

Continued



#### WARNING

Do not touch the drive unit when the **DC-BUS High Voltage LED** is on.  
There is residual voltage in the drive unit even if the main switch is in the OFF position.

#### Required spare parts



#### Note

The spare part numbers that are listed in the table can be out of date. See the latest spare parts of the OmniCore V250XT Type B via myABB Business Portal, [www.abb.com/myABB](http://www.abb.com/myABB).

Spare part	Article number	Note
Drive unit, High Voltage	3HAC064590-001	DSQC3062
Harness DC-bus	3HAC065225-001	Harness A1.X4 - T4.X5
Harness 24_SYS_DRV	3HAC081734-001	Harness A1.X5 - T4.X1
Ethernet harness	3HAC081970-001	Harness A1.X12 - T4.X3
Harness 24_BRAKE	3HAC081731-001	Harness A1.X11 - T4.X13
Harness CTRL_FB	3HAC082738-001	Harness A1.X2 - T4.X17

#### Required tools and equipment

Equipment	Article number	Note
Standard toolkit	-	Content is defined in section <a href="#">Standard toolkit for controller on page 436</a> .
ESD protective wrist band	-	

#### Required documents

Document	Article number	Note
<i>Circuit diagram - OmniCore V250XT</i> , rev 04 or later	3HAC074000-008	

#### Removing the drive unit

##### Preparations



	Action	Note/Illustration
1	 <b>DANGER</b> Before doing any work inside the cabinet, disconnect the mains power. For more information, see <a href="#">Electrical safety on page 29</a> .	
2	Open the door.	<a href="#">Opening the door on page 188</a> .

Continues on next page

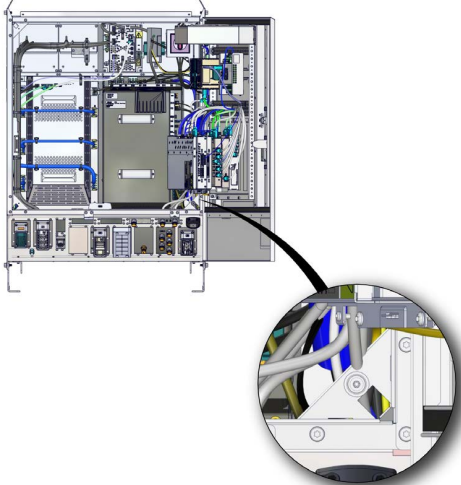

	Action	Note/Illustration
3	<p> <b>ELECTROSTATIC DISCHARGE (ESD)</b></p> <p>The unit is sensitive to ESD. Before handling the unit read the safety information in section <i>The unit is sensitive to ESD on page 45.</i></p>	<p>Location of wrist strap button:</p>  <p>xx2200001817</p>

Removing the drive unit

	Action	Note/Illustration
1	<p>Disconnect all connectors from the unit to be replaced.</p>	
2	<p>Remove the screws and pull the drive unit out from the two guiding pins on the mounting plate.</p> <p> <b>CAUTION</b></p> <p>The weight of the drive unit is 11 kg. Use protective gloves when lifting this unit.</p> <p> <b>CAUTION</b></p> <p>The cabling is sensitive to mechanical damage. Handle it with care to avoid damage to the cabling or the connector, avoid any kind of tilt or skew.</p>	<p>Lengthened screwdriver</p>  <p>xx2100000338</p>

Continues on next page





## 5 Repair

### 5.2.13 Replacing the drive unit

Continued

#### Refitting the drive unit

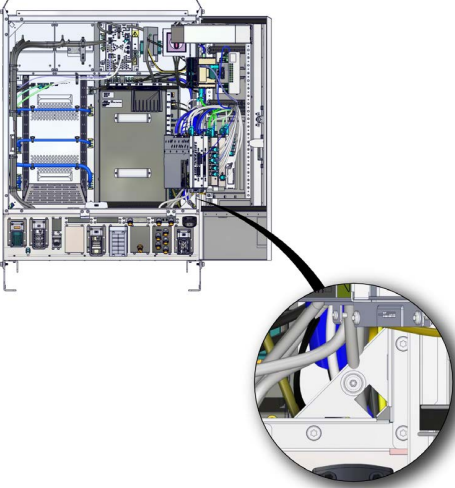
#### Refitting the drive unit

	Action	Note/Illustration
1	 <p><b>DANGER</b></p> <p>Before doing any work inside the cabinet, disconnect the mains power. For more information, see <a href="#">Electrical safety on page 29</a>.</p>	
2	 <p><b>ELECTROSTATIC DISCHARGE (ESD)</b></p> <p>The unit is sensitive to ESD. Before handling the unit read the safety information in section <a href="#">The unit is sensitive to ESD on page 45</a>.</p>	<p>Location of wrist strap button:</p>  <p>xx2200001817</p>
3	<p>Position the drive unit on the lower guiding pin on the mounting plate, and then tip the unit upwards against the upper guiding pin. Secure the screws.</p>	<p>Screws: Torx pan head screw M4x8 (4 pcs) Tightening torque: 2 Nm</p>  <p>xx2100000338</p>

Continues on next page

	<b>Action</b>	<b>Note/Illustration</b>
4	Reconnect any connectors disconnected at removal.	

## Concluding procedure

	<b>Action</b>	<b>Note/Illustration</b>
1	Close the door.	<i>Closing the door on page 189.</i>
2	Perform the function tests to verify that the safety features work properly, see <i>Function tests on page 177.</i>	

## 5 Repair

### 5.2.14 Replacing the additional drive unit

#### 5.2.14 Replacing the additional drive unit

##### Location

The illustration shows the location of the additional drive unit in the controller.

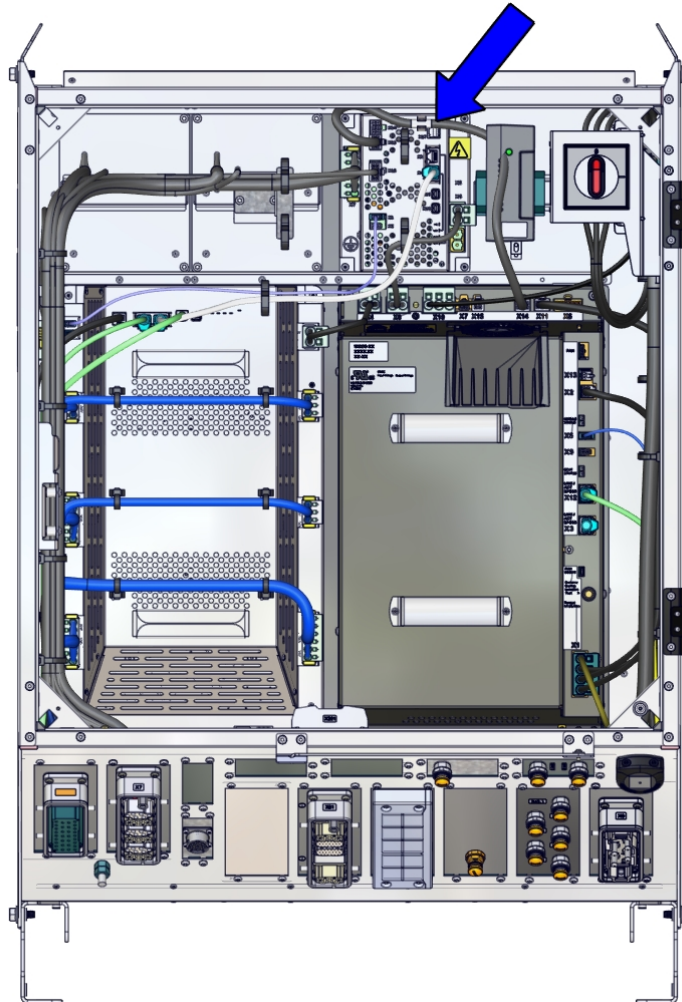

xx2200001056



#### WARNING

Do not touch the drive unit when the **DC-BUS High Voltage LED** is on.  
There is residual voltage in the drive unit even if the main switch is in the OFF position.

##### Required spare parts



#### Note

The spare part numbers that are listed in the table can be out of date. See the latest spare parts of the OmniCore V250XT Type B via myABB Business Portal, [www.abb.com/myABB](http://www.abb.com/myABB).

*Continues on next page*

Spare part	Article number	Note
Drive unit	3HAC064983-001	DSQC 3065

**Required tools and equipment**



Equipment	Article number	Note
Standard toolkit	-	Content is defined in section <a href="#">Standard toolkit for controller on page 436</a> .
ESD protective wrist band	-	

**Required documents**

Document	Article number	Note
<i>Circuit diagram - OmniCore V250XT, rev 04 or later</i>	3HAC074000-008	

**Removing the additional drive unit**

Preparations

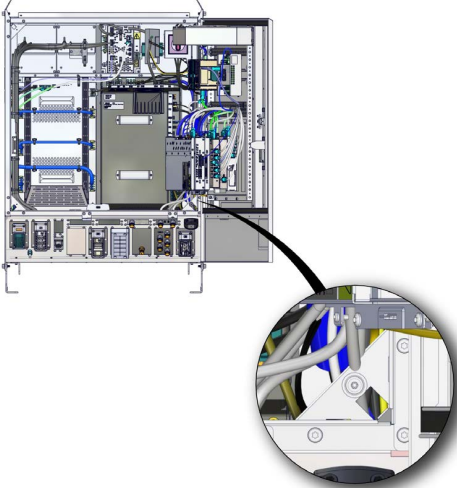
Action	Note/Illustration
<p>1</p>  <p><b>DANGER</b></p> <p>Before doing any work inside the cabinet, disconnect the mains power. For more information, see <a href="#">Electrical safety on page 29</a>.</p>	
<p>2</p> <p>Open the door.</p>	<p><a href="#">Opening the door on page 188</a>.</p>
<p>3</p>  <p><b>ELECTROSTATIC DISCHARGE (ESD)</b></p> <p>The unit is sensitive to ESD. Before handling the unit read the safety information in section <a href="#">The unit is sensitive to ESD on page 45</a>.</p>	<p>Location of wrist strap button:</p>  <p>xx2200001817</p>



Continues on next page

## 5 Repair

### 5.2.14 Replacing the additional drive unit

Continued

#### Removing the drive unit

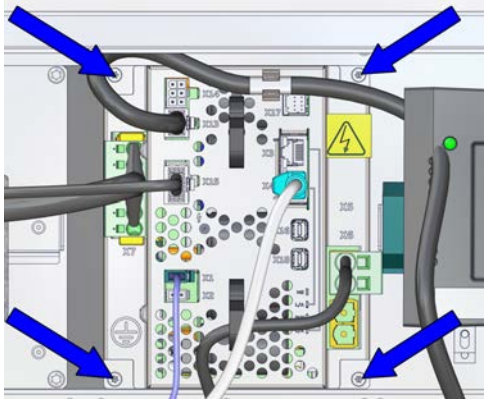
	Action	Note/Illustration
1	<p>Pull the cable ties out from the locking holes.</p> <p> <b>Tip</b></p> <p>Take photos of the cable ties and locking holes before pulling out, to have as a reference when refitting the cable ties.</p>	
2	<p>Disconnect all connectors from the unit to be replaced.</p>	
3	<p>Remove the screws and pull the drive unit out from the two guiding pins on the mounting plate.</p> <p> <b>CAUTION</b></p> <p>The cabling is sensitive to mechanical damage. Handle it with care to avoid damage to the cabling or the connector, avoid any kind of tilt or skew.</p>	<p>Lengthened screwdriver</p>  <p>xx2200001375</p>

#### Refitting the additional drive unit

#### Refitting the additional drive unit

	Action	Note/Illustration
1	<p> <b>DANGER</b></p> <p>Before doing any work inside the cabinet, disconnect the mains power. For more information, see <a href="#">Electrical safety on page 29</a>.</p>	

Continues on next page

5.2.14 Replacing the additional drive unit  
Continued

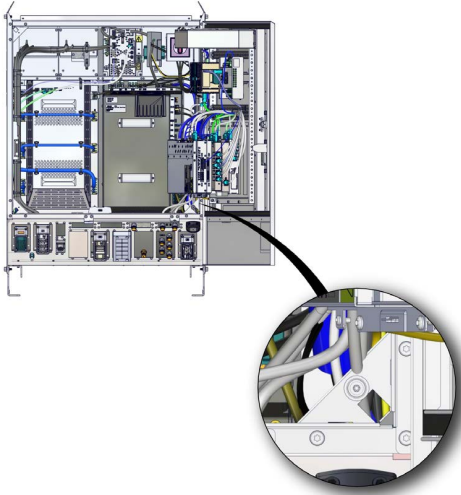
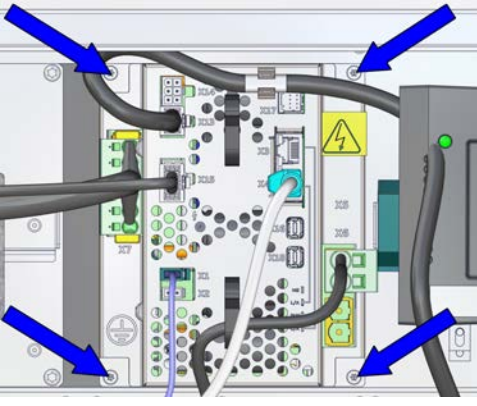
	Action	Note/Illustration
2	<p> <b>ELECTROSTATIC DISCHARGE (ESD)</b></p> <p>The unit is sensitive to ESD. Before handling the unit read the safety information in section <a href="#">The unit is sensitive to ESD on page 45</a>.</p>	<p>Location of wrist strap button:</p>  <p>xx2200001817</p>
3	<p>Refit the additional drive unit and secure with the screws.</p>	<p>Screws: Torx pan head screw M4x8 (4 pcs) Tightening torque: 2 Nm</p>  <p>xx2200001375</p>
4	<p>Reconnect any connectors disconnected at removal.</p>	

Concluding procedure

	Action	Note/Illustration
1	<p>Close the door.</p>	<p><a href="#">Closing the door on page 189</a>.</p>
2	<p>Perform the function tests to verify that the safety features work properly, see <a href="#">Function tests on page 177</a>.</p>	



## 5 Repair

### 5.2.15 Replacing the DeviceNet board

#### 5.2.15 Replacing the DeviceNet board

##### Location

The illustration shows the location of the DeviceNet board DSQC1096 in the main computer.

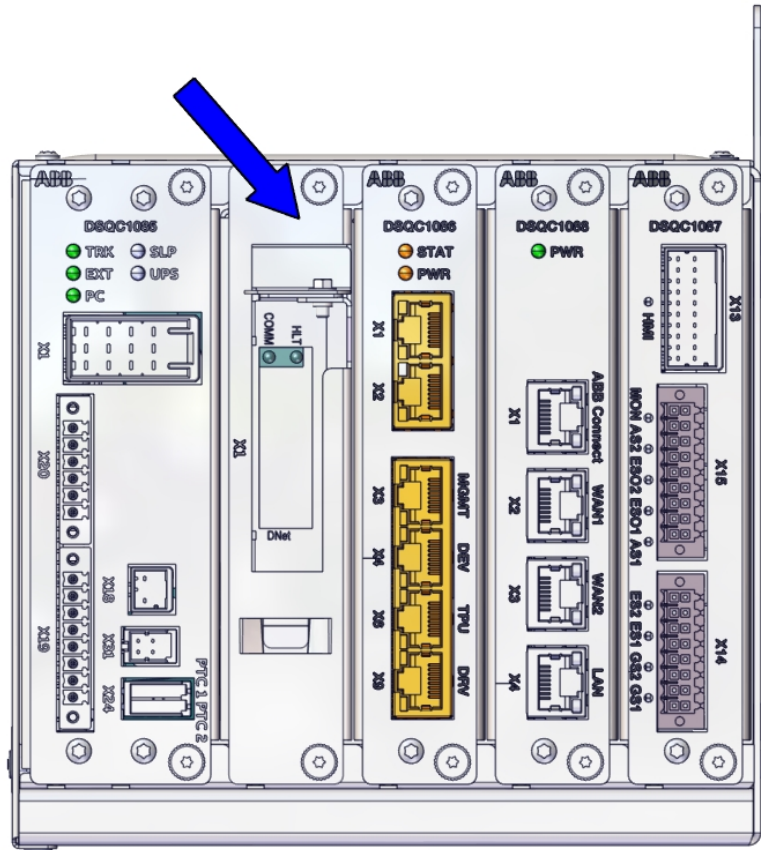

xx2300001738

##### Required spare parts



##### Note

The spare part numbers that are listed in the table can be out of date. See the latest spare parts of the OmniCore V250XT Type B via myABB Business Portal, [www.abb.com/myABB](http://www.abb.com/myABB).

Spare part	Article number	Note
DeviceNet M/S [3029-1]	3HAC085254-001	DSQC1096

##### Required tools and equipment

Equipment	Article number	Note
Standard toolkit	-	Content is defined in section <a href="#">Standard toolkit for controller on page 436</a> .

Continues on next page





Equipment	Article number	Note
ESD protective wrist band	-	

Required documents

Document	Article number	Note
Circuit diagram - OmniCore V250XT, rev 04 or later	3HAC074000-008	

Removing the DeviceNet board

Preparations

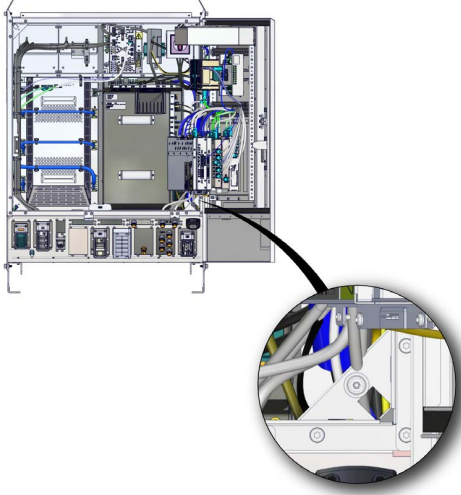
	Action	Note/Illustration
1	 <p><b>DANGER</b></p> <p>Before doing any work inside the cabinet, disconnect the mains power. For more information, see <a href="#">Electrical safety on page 29</a>.</p>	
2	Open the door.	<a href="#">Opening the door on page 188</a> .
3	 <p><b>ELECTROSTATIC DISCHARGE (ESD)</b></p> <p>The unit is sensitive to ESD. Before handling the unit read the safety information in section <a href="#">The unit is sensitive to ESD on page 45</a>.</p>	<p>Location of wrist strap button:</p>  <p>xx2200001817</p>

Continues on next page

## 5 Repair

### 5.2.15 Replacing the DeviceNet board

*Continued*

#### Removing the DeviceNet board

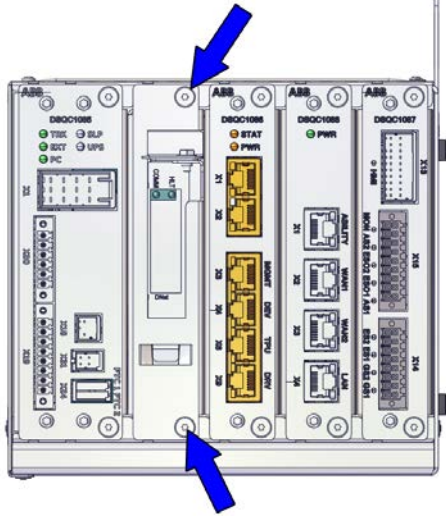
	Action	Note/Illustration
1	Loosen the screws that hold the DeviceNet board unit.	 <p>xx230000921</p>
2	Remove the DeviceNet board unit from the slot in the main computer assembly.	

#### Refitting the DeviceNet board

##### Preparations

	Action	Note/Illustration
1	 <p><b>DANGER</b></p> <p>Before doing any work inside the cabinet, disconnect the mains power. For more information, see <a href="#">Electrical safety on page 29</a>.</p>	
2	Open the door.	<a href="#">Opening the door on page 188</a> .

*Continues on next page*

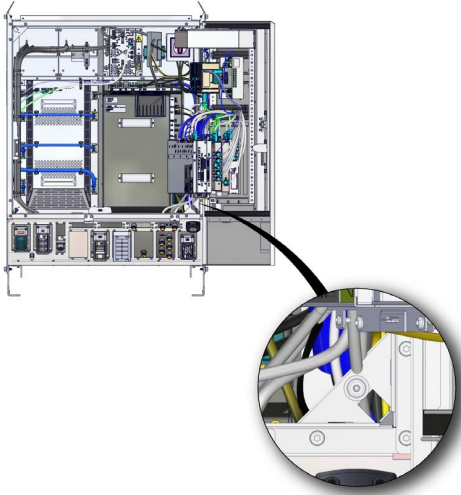
	Action	Note/Illustration
3	<p> <b>ELECTROSTATIC DISCHARGE (ESD)</b></p> <p>The unit is sensitive to ESD. Before handling the unit read the safety information in section <a href="#">The unit is sensitive to ESD on page 45</a>.</p>	<p>Location of wrist strap button:</p>  <p>xx2200001817</p>

Refitting the DeviceNet board

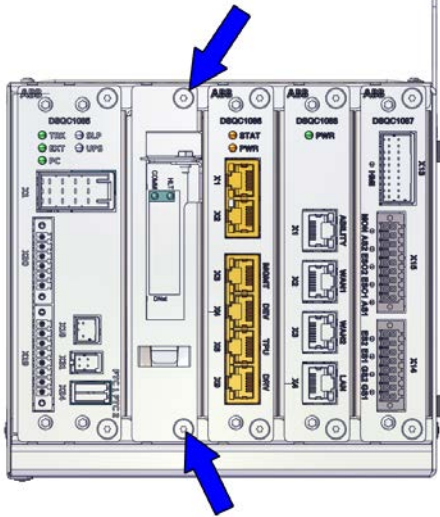
	Action	Note/Illustration
1	<p>Insert the DeviceNet board into the slot in the main computer assembly.</p>	
2	<p>Secure the screws that hold the DeviceNet board unit.</p>	 <p>xx2300000921</p>

Concluding procedure

	Action	Note/Illustration
1	<p>Close the door.</p>	<p><a href="#">Closing the door on page 189</a>.</p>
2	<p>Perform the function tests to verify that the safety features work properly, see <a href="#">Function tests on page 177</a>.</p>	

## 5 Repair

### 5.2.16 Replacing the conveyor tracking module (CTM)

### 5.2.16 Replacing the conveyor tracking module (CTM)

#### Location

The illustration shows the location of the conveyor tracking module in the controller.

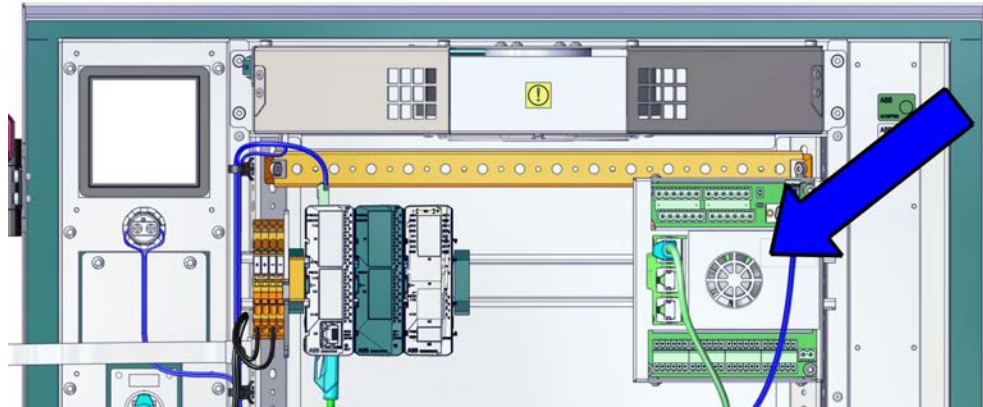

xx2300001840

#### Required spare parts



#### Note

The spare part numbers that are listed in the table can be out of date. See the latest spare parts of the OmniCore V250XT Type B via myABB Business Portal, [www.abb.com/myABB](http://www.abb.com/myABB).

Spare part	Article number	Note
Conveyor tracking module [3103-1]	3HNA027579-001	DSQC2000
CONNECTOR KIT - DSQC2000	3HNA029345-001	
Harness 24V_CTM	3HAC084173-001	Power cable of CTM
Ethernet harness for CTM	3HAC084195-001	

#### Required tools and equipment

Equipment	Article number	Note
Standard toolkit	-	Content is defined in section <a href="#">Standard toolkit for controller on page 436</a> .
ESD protective wrist band	-	



#### Required documents

Document	Article number	Note
<i>Circuit diagram - OmniCore V250XT, rev 04 or later</i>	<i>3HAC074000-008</i>	
<i>Application manual - Conveyor tracking</i>	<i>3HAC066561-001</i>	

Continues on next page

Removing the conveyor tracking module (option)

Preparations

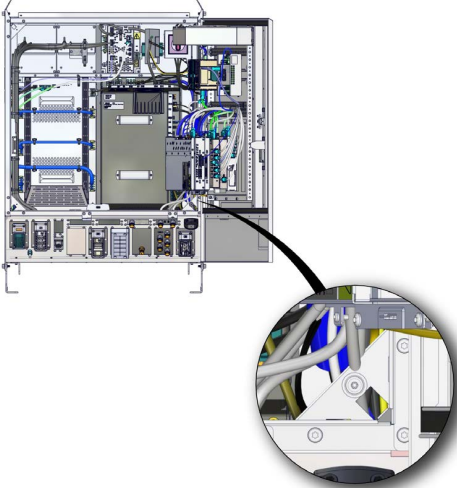
	Action	Note/Illustration
1	 <b>DANGER</b> Before doing any work inside the cabinet, disconnect the mains power. For more information, see <a href="#">Electrical safety on page 29</a> .	
2	Open the door.	<a href="#">Opening the door on page 188</a> .
3	 <b>ELECTROSTATIC DISCHARGE (ESD)</b> The unit is sensitive to ESD. Before handling the unit read the safety information in section <a href="#">The unit is sensitive to ESD on page 45</a> .	Location of wrist strap button:  xx2200001817

Removing the conveyor tracking module (option)

	Action	Note/Illustration
1	Disconnect all connectors from the unit to be replaced.	

Continues on next page

## 5 Repair

### 5.2.16 Replacing the conveyor tracking module (CTM)

Continued

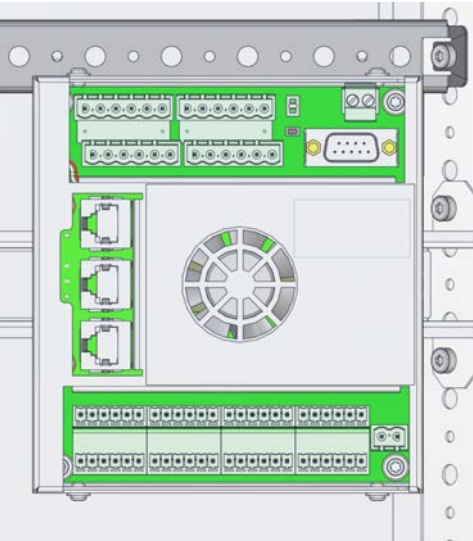
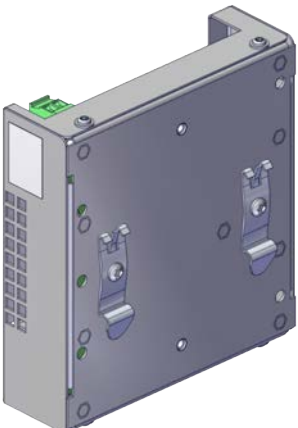
	Action	Note/Illustration
2	<p>Pull on the lower side of the conveyor tracking module slightly and take out the conveyor tracking module.</p> <p> <b>Note</b></p> <p>The conveyor tracking module is secured by the buckles.</p> <p>Be careful with the direction of the buckles when doing assembling/disassembling work.</p>	 <p>xx2200001844</p>  <p>xx1900001913</p>

### Refitting the conveyor tracking module (option)

#### Refitting the conveyor tracking module (option)

	Action	Note/Illustration
1	<p> <b>DANGER</b></p> <p>Before doing any work inside the cabinet, disconnect the mains power. For more information, see <a href="#">Electrical safety on page 29</a>.</p>	

Continues on next page

5.2.16 Replacing the conveyor tracking module (CTM)

Continued

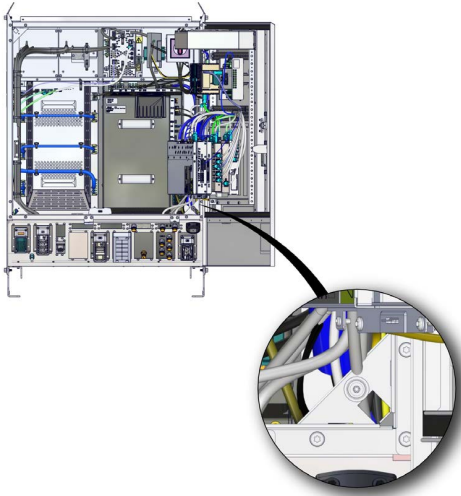
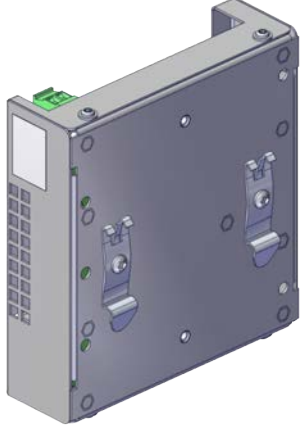
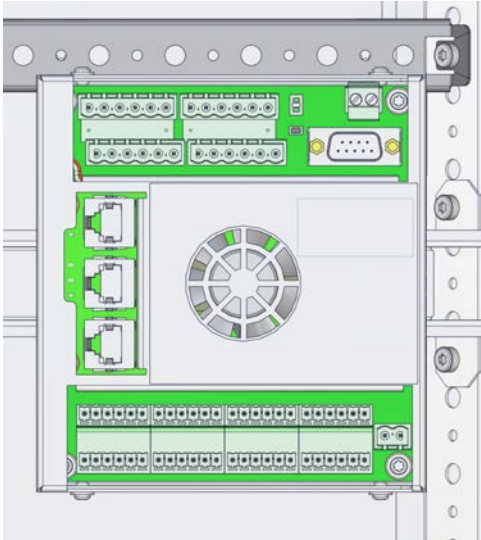
	Action	Note/Illustration
2	<p> <b>ELECTROSTATIC DISCHARGE (ESD)</b></p> <p>The unit is sensitive to ESD. Before handling the unit read the safety information in section <i>The unit is sensitive to ESD on page 45.</i></p>	<p>Location of wrist strap button:</p>  <p>xx2200001817</p>
3	<p>Hang the conveyor tracking module into the bracket and push the lower of it until you hear a clear clicking sound.</p>	 <p>xx1900001913</p>  <p>xx2200001844</p>

Continues on next page

## 5 Repair

---

### 5.2.16 Replacing the conveyor tracking module (CTM)

*Continued*

	Action	Note/Illustration
4	Reconnect any connectors disconnected at removal.	
5	Stick the other connector onto the side of the digital base with the self-adhesive part.	

#### Concluding procedure

	Action	Note/Illustration
1	Close the door.	<a href="#">Closing the door on page 189.</a>
2	Perform the function tests to verify that the safety features work properly, see <a href="#">Function tests on page 177.</a>	



## 5.2.17 Replacing the air filter

### Location

The illustration shows the location of the air filter on the controller.



xx2200001484

*Continues on next page*

## 5 Repair

### 5.2.17 Replacing the air filter

*Continued*

#### Required spare parts



#### Note

The spare part numbers that are listed in the table can be out of date. See the latest spare parts of the OmniCore V250XT Type B via myABB Business Portal, [www.abb.com/myABB](http://www.abb.com/myABB).

Spare part	Article number	Note
Air filter coarse assembly	3HAC082548-001	Option 3005-1 Moist particle filter
Air filter fine assembly	3HAC082547-001	Option 3005-2 Moist dust filter
Air filter, fine (Polymeric)	3HAC084607-001	Option 3005-2 Moist dust filter

#### Required tools and equipment

Equipment	Article number	Note
Standard toolkit	-	Content is defined in section <a href="#">Standard toolkit for controller on page 436</a> .
ESD protective wrist band	-	

#### Required documents

Document	Article number	Note
<i>Circuit diagram - OmniCore V250XT</i> , rev 04 or later	3HAC074000-008	

#### Removing the air filter

##### Preparations

	Action	Note/Illustration
1	 <b>DANGER</b> Before doing any work inside the cabinet, disconnect the mains power. For more information, see <a href="#">Electrical safety on page 29</a> .	

*Continues on next page*

Removing the air filter

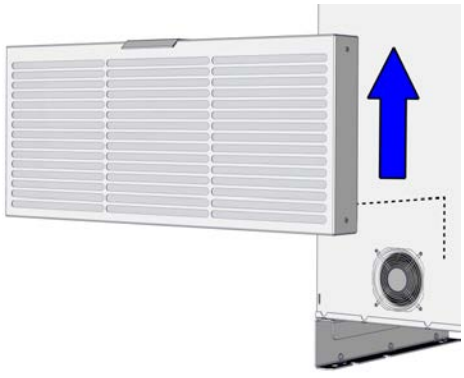
	Action	Note/Illustration
1	Remove the air filter unit.	 <p>xx2200001773</p>

Removing the polymeric filter element

The procedure below details how to remove the polymeric filter element (option 3005-2 Moist dust filter).

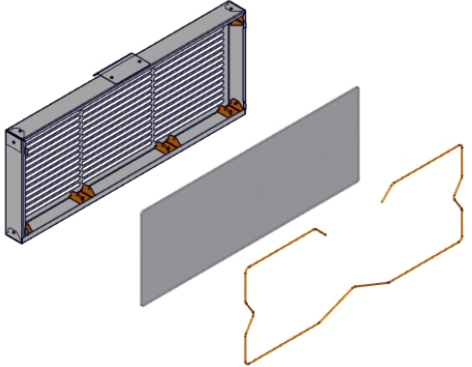
	Action	Note/Illustration
1	Take out the polymeric filter element from the filter.	 <p>xx2200001827</p>

Continues on next page

## 5 Repair

### 5.2.17 Replacing the air filter

*Continued*

#### Refitting the air filter

##### Refitting the polymeric filter element

The procedure below details how to refit the polymeric filter element (option 3005-2 *Moist dust filter*).

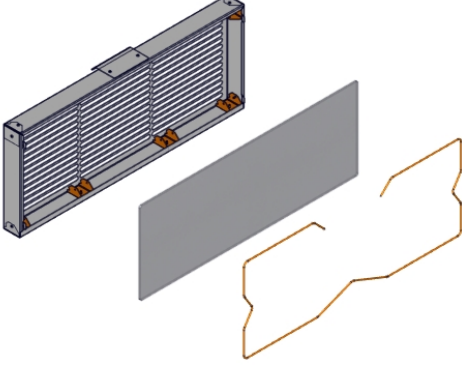
	Action	Note/Illustration
1	Insert the polymeric filter element to the filter and secure with the metallic line.	 <p>xx2200001827</p>

#### Refitting the air filter

	Action	Note/Illustration
1	 <b>DANGER</b> Before doing any work inside the cabinet, disconnect the mains power. For more information, see <a href="#">Electrical safety on page 29</a> .	
2	Refit the air filter unit to the cabinet.	

#### Concluding procedure

	Action	Note/Illustration
1	Perform the function tests to verify that the safety features work properly, see <a href="#">Function tests on page 177</a> .	

## 5.2.18 Replacing the break resistor bleeder

### Location

The illustration shows the location of the break resistor bleeder in the controller.

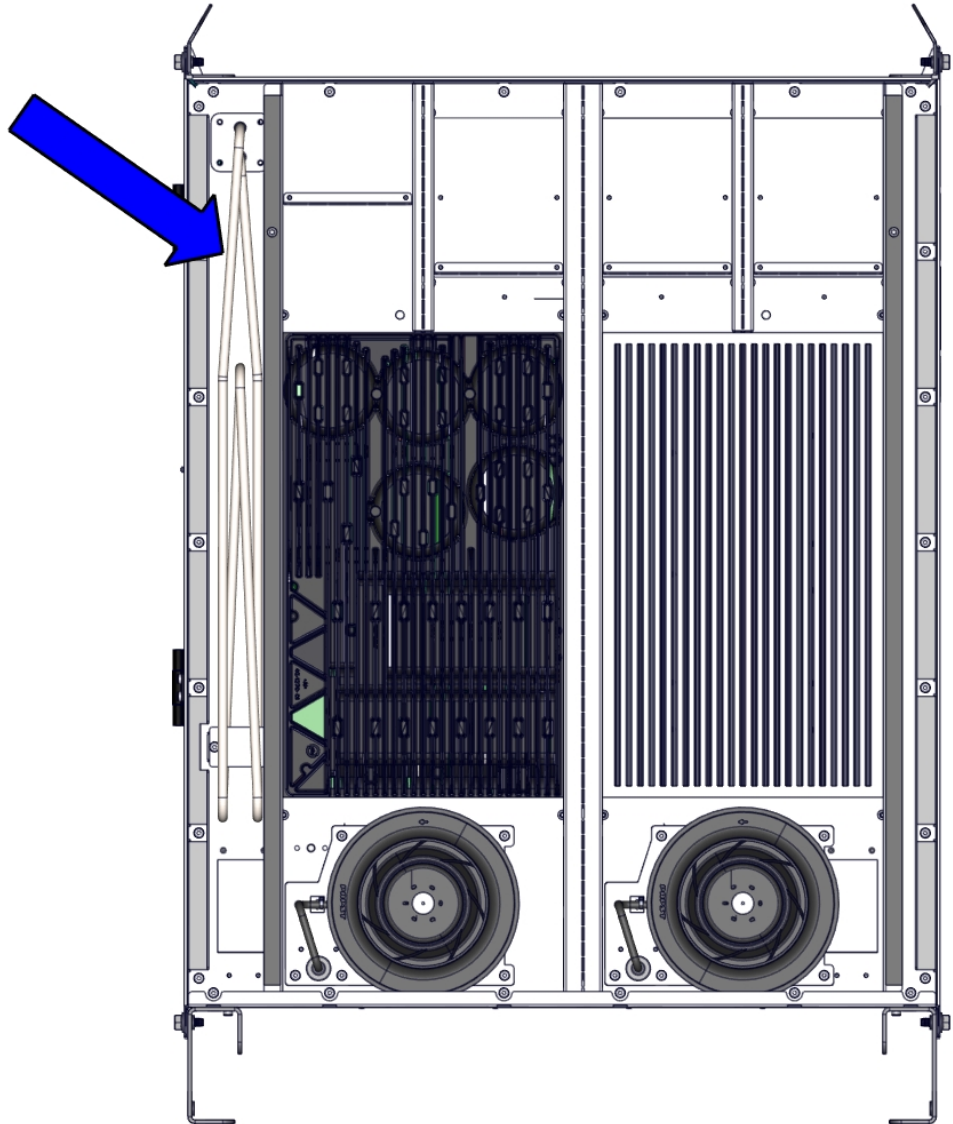

xx2200001072

### Required spare parts



#### Note

The spare part numbers that are listed in the table can be out of date. See the latest spare parts of the OmniCore V250XT Type B via myABB Business Portal, [www.abb.com/myABB](http://www.abb.com/myABB).

*Continues on next page*

## 5 Repair

### 5.2.18 Replacing the break resistor bleeder

Continued

Spare part	Article number	Note
Break resistor bleeder assembly	3HAC081951-001	

#### Required tools and equipment



Equipment	Article number	Note
Standard toolkit	-	Content is defined in section <a href="#">Standard toolkit for controller on page 436</a> .
ESD protective wrist band	-	

#### Required documents

Document	Article number	Note
<i>Circuit diagram - OmniCore V250XT, rev 04 or later</i>	3HAC074000-008	

#### Removing the break resistor bleeder

##### Preparations

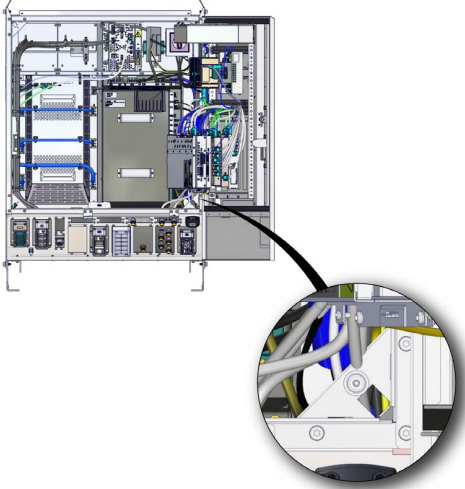
	Action	Note/Illustration
1	 <b>DANGER</b> Before doing any work inside the cabinet, disconnect the mains power. For more information, see <a href="#">Electrical safety on page 29</a> .	
2	 <b>ELECTROSTATIC DISCHARGE (ESD)</b> The unit is sensitive to ESD. Before handling the unit read the safety information in section <a href="#">The unit is sensitive to ESD on page 45</a> .	Location of wrist strap button:  xx2200001817
3	Remove the rear cover of the controller.	<a href="#">Removing the rear cover on page 190</a> .
4	Open the door.	<a href="#">Opening the door on page 188</a> .

Continues on next page

Removing the break resistor bleeder

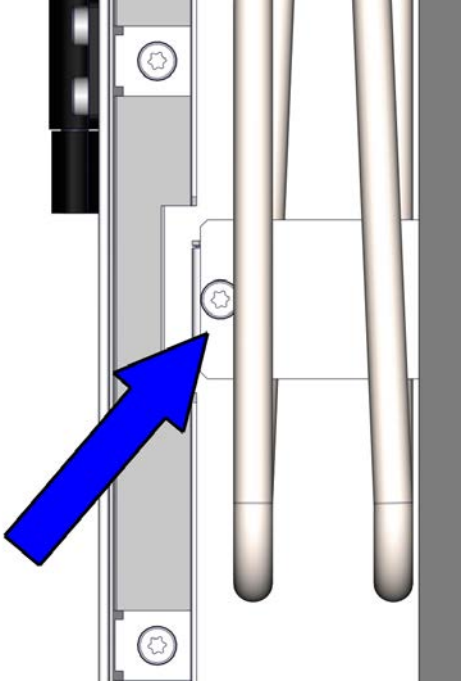
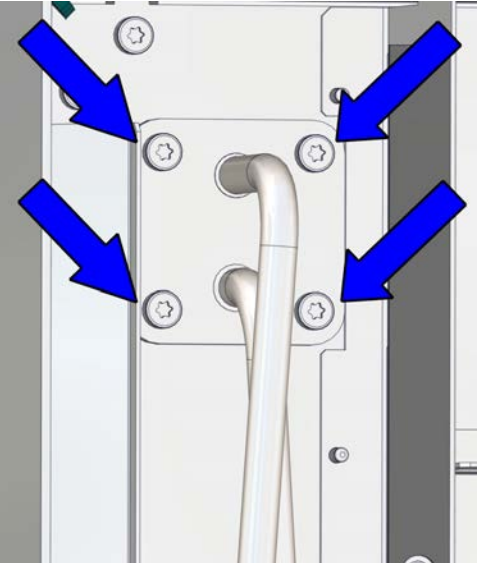
	Action	Note/Illustration
1	Remove the cable ties.	
2	Disconnect all connectors from the unit to be replaced.	
3	Remove the screw holding the break resistor bleeder bracket.	 <p>xx2200001073</p>
4	Remove the screws holding the break resistor bleeder.	 <p>xx2200001074</p>
5	Remove the break resistor bleeder and pull the cables through the opening.	

Continues on next page



## 5 Repair

### 5.2.18 Replacing the break resistor bleeder

*Continued*

#### Refitting the break resistor bleeder

#### Refitting the break resistor bleeder

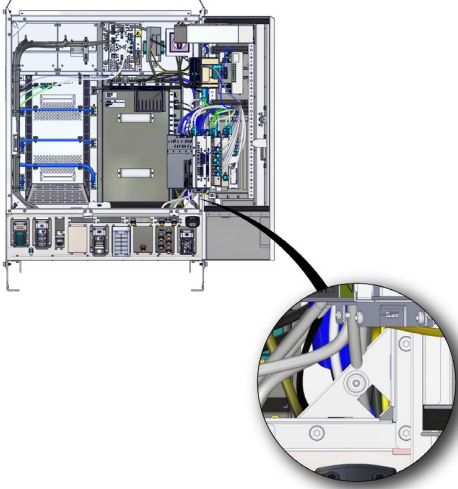
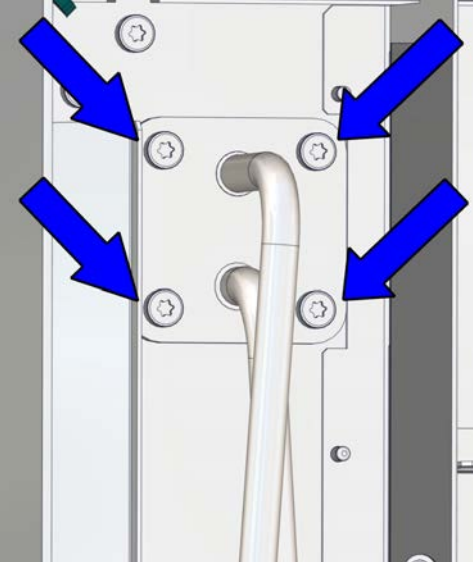
	Action	Note/Illustration
1	 <p><b>DANGER</b></p> <p>Before doing any work inside the cabinet, disconnect the mains power. For more information, see <a href="#">Electrical safety on page 29</a>.</p>	
2	 <p><b>ELECTROSTATIC DISCHARGE (ESD)</b></p> <p>The unit is sensitive to ESD. Before handling the unit read the safety information in section <a href="#">The unit is sensitive to ESD on page 45</a>.</p>	<p>Location of wrist strap button:</p>  <p>xx2200001817</p>
3	<p>Refit the break resistor bleeder and secure the screws.</p>	 <p>xx2200001074</p>

*Continues on next page*

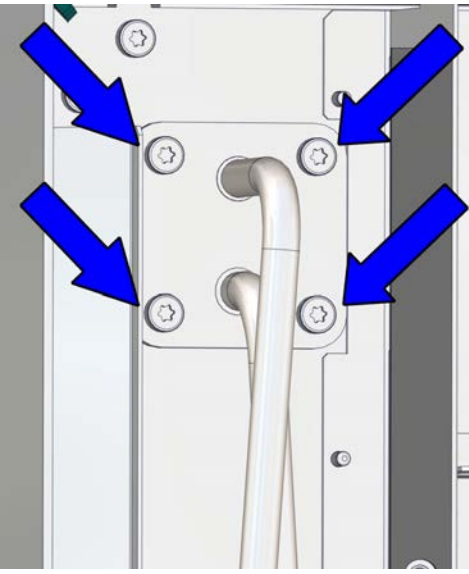

	Action	Note/Illustration
4	Secure the screw holding the break resistor bleeder bracket.	 <p>xx2200001074</p>
5	Reconnect any connectors disconnected at removal.	

Concluding procedure

	Action	Note/Illustration
1	Refit the rear cover of the controller.	<a href="#">Refitting the rear cover on page 191.</a>
2	Close the door.	<a href="#">Closing the door on page 189.</a>
3	Perform the function tests to verify that the safety features work properly, see <a href="#">Function tests on page 177.</a>	

## 5 Repair

### 5.3.1 Replacing the manipulator signal connector (SMB)

## 5.3 Replacing parts on the front panel and door

### 5.3.1 Replacing the manipulator signal connector (SMB)

#### Location

The illustration shows the location of the manipulator signal connector.

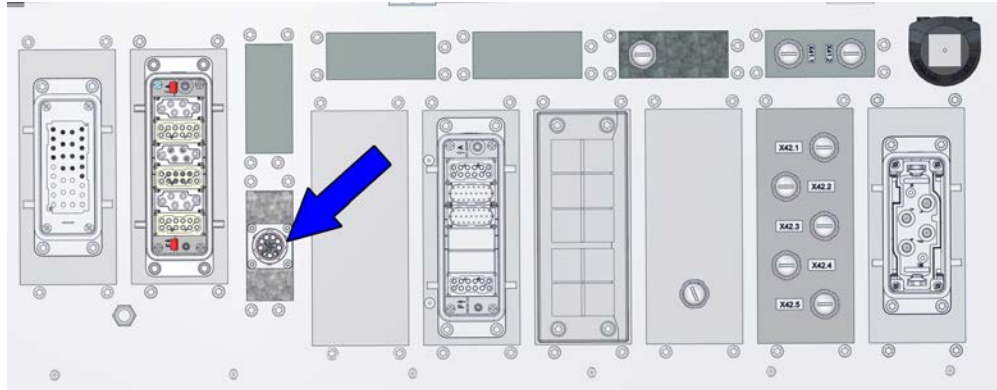

xx2200001956

#### Required spare parts



#### Note

The spare part numbers that are listed in the table can be out of date. See the latest spare parts of the OmniCore V250XT Type B via myABB Business Portal, [www.abb.com/myABB](http://www.abb.com/myABB).

Spare part	Article number	Note
Harness SMB connection	3HAC081735-001	Harness 1xSMB
Harness SMB link	3HAC077440-001	Harness 1xSMB
Harness SMB link	3HAC077388-001	Harness 2xSMB
Harness SMB link	3HAC083231-001	LV

#### Required tools and equipment

Equipment	Article number	Note
Standard toolkit	-	Content is defined in section <a href="#">Standard toolkit for controller on page 436</a> .
ESD protective wrist band	-	



#### Required documents

Document	Article number	Note
<i>Circuit diagram - OmniCore V250XT, rev 04 or later</i>	3HAC074000-008	

*Continues on next page*

Removing the manipulator signal connector

Preparations

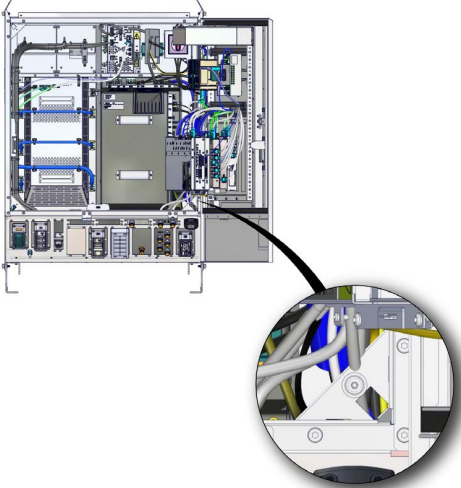
	Action	Note/Illustration
1	 <b>DANGER</b> Before doing any work inside the cabinet, disconnect the mains power. For more information, see <a href="#">Electrical safety on page 29</a> .	
2	Open the door.	<a href="#">Opening the door on page 188</a> .
3	 <b>ELECTROSTATIC DISCHARGE (ESD)</b> The unit is sensitive to ESD. Before handling the unit read the safety information in section <a href="#">The unit is sensitive to ESD on page 45</a> .	Location of wrist strap button:  xx2200001817

Removing the manipulator signal connector

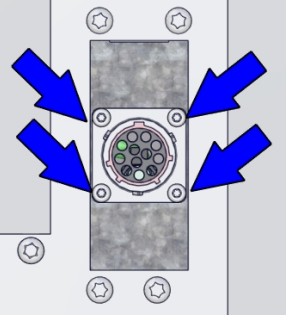
	Action	Note/Illustration
1	Disconnect all connectors from the unit to be replaced.	
2	Remove cable ties and cable supports.	
3	Remove nuts and attachment screws.	 xx2200001981
4	Push the manipulator signal connector out through the front panel.	

Continues on next page



## 5 Repair

### 5.3.1 Replacing the manipulator signal connector (SMB)

*Continued*

#### Refitting the manipulator signal connector

#### Refitting the manipulator signal connector

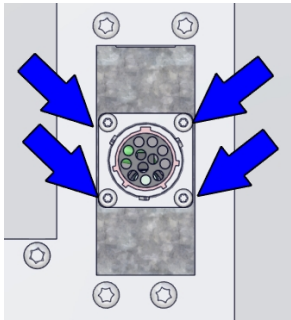
	Action	Note/Illustration
1	 <b>DANGER</b> Before doing any work inside the cabinet, disconnect the mains power. For more information, see <a href="#">Electrical safety on page 29</a> .	
2	 <b>ELECTROSTATIC DISCHARGE (ESD)</b> The unit is sensitive to ESD. Before handling the unit read the safety information in section <a href="#">The unit is sensitive to ESD on page 45</a> .	
3	Insert the manipulator signal connector into the cover plate in the front panel.	
4	Secure it with the attachment screws.	Screws: Torx pan head screw M4x8 (4 pcs) Tightening torque: 2.7 Nm±10%.  xx2200001981
5	Reconnect any connectors disconnected at removal.	

#### Concluding procedure

	Action	Note/Illustration
1	Close the door.	<a href="#">Closing the door on page 189</a> .
2	Perform the function tests to verify that the safety features work properly, see <a href="#">Function tests on page 177</a> .	

## 5.3.2 Replacing the motor connector

### Location

The illustration shows the location of the motor connector in the controller.

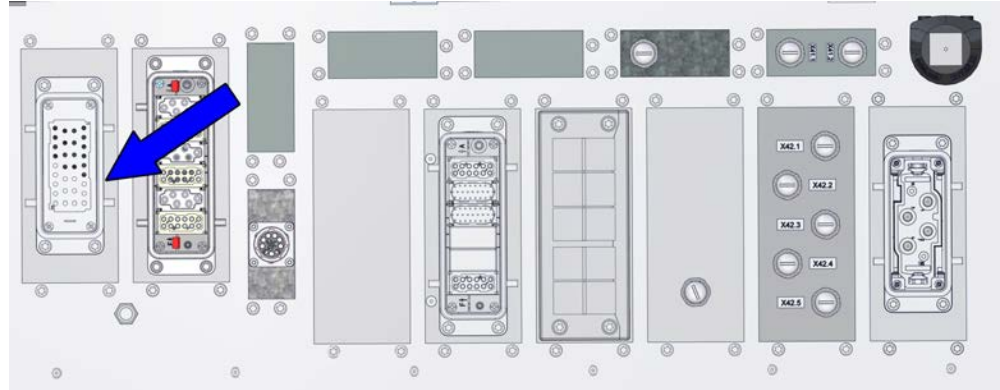

xx2200001957

### Required spare parts



#### Note

The spare part numbers that are listed in the table can be out of date. See the latest spare parts of the OmniCore V250XT Type B via myABB Business Portal, [www.abb.com/myABB](http://www.abb.com/myABB).

Spare part	Article number	Note
Harness HV Manipulator Motor	3HAC081696-001	
Harness Manipulator Motor	3HAC089244-001	Harness for IRB 2400
Harness Manipulator Motor	3HAC089245-001	Harness for IRB 4400

### Required tools and equipment

Equipment	Article number	Note
Standard toolkit	-	Content is defined in section <a href="#">Standard toolkit for controller on page 436</a> .
ESD protective wrist band	-	

### Required documents

Document	Article number	Note
<i>Circuit diagram - OmniCore V250XT</i> , rev 04 or later	3HAC074000-008	

*Continues on next page*



## 5 Repair

### 5.3.2.1 Replacing the motor connector

#### 5.3.2.1 Replacing the motor connector

##### Removing the motor connector

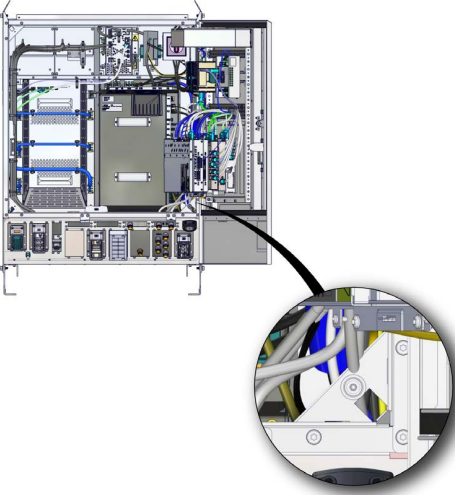

##### Preparations

	Action	Note/Illustration
1	 <b>DANGER</b> Before doing any work inside the cabinet, disconnect the mains power. For more information, see <a href="#">Electrical safety on page 29</a> .	
2	Open the door.	<a href="#">Opening the door on page 188</a> .
3	 <b>ELECTROSTATIC DISCHARGE (ESD)</b> The unit is sensitive to ESD. Before handling the unit read the safety information in section <a href="#">The unit is sensitive to ESD on page 45</a> .	Location of wrist strap button:  xx2200001817

##### Removing the motor connector

	Action	Note/Illustration
1	Disconnect all connectors from the unit to be replaced.	

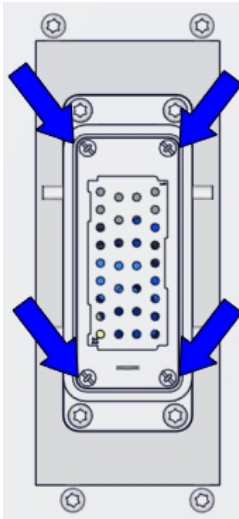
*Continues on next page*

	Action	Note/Illustration
2	Remove the attachment screws on the connector.	 <p>xx2200001982</p>
3	Push the motor connector into the cabinet.	
4	Take the motor connector cable out from the velcro in the cabinet.   <b>Note</b>  Make records about the sequence that cables are removed. The cables need to be installed in the same position.	
5	Take out the motor connector.	

**Refitting the motor connector**

Refitting the motor connector



	Action	Note/Illustration
1	 <b>DANGER</b>  Before doing any work inside the cabinet, disconnect the mains power. For more information, see <a href="#">Electrical safety on page 29</a> .	

Continues on next page

## 5 Repair

### 5.3.2.1 Replacing the motor connector

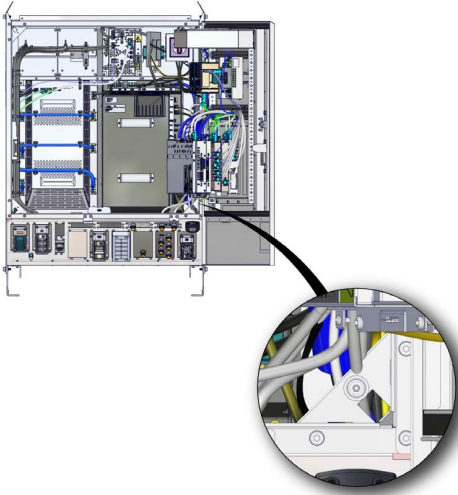
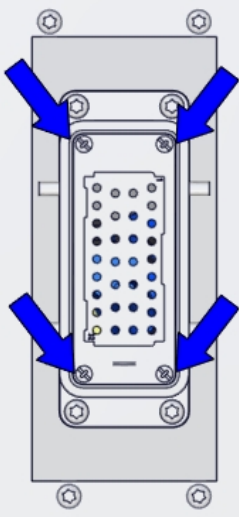
Continued

	Action	Note/Illustration
2	 <p><b>ELECTROSTATIC DISCHARGE (ESD)</b></p> <p>The unit is sensitive to ESD. Before handling the unit read the safety information in section <i>The unit is sensitive to ESD on page 45</i>.</p>	<p>Location of wrist strap button:</p>  <p>xx2200001817</p>
3	<p>Insert the motor connector into the front panel from inner side of the cabinet and fasten it with the screws.</p>	<p>Screws: Torx, countersunk screw M4x10 (4 pcs)</p> <p>Tightening torque: 2.7 Nm±10%.</p>  <p>xx2200001982</p>
4	<p>Reconnect any connectors disconnected at removal.</p>	
5	<p>Secure the motor connector cables with the velcro on the frame of the cabinet.</p>  <p><b>Tip</b></p> <p>Use the same position as from removing the motor connector.</p>	

Continues on next page



#### Concluding procedure

	Action	Note/Illustration
1	Close the door.	<a href="#">Closing the door on page 189.</a>
2	Perform the function tests to verify that the safety features work properly, see <a href="#">Function tests on page 177.</a>	

## 5 Repair

### 5.3.3 Replacing the HMI signal (FlexPendant) connector

### 5.3.3 Replacing the HMI signal (FlexPendant) connector

#### Location

The illustration shows the location of the HMI signal connector in the controller.

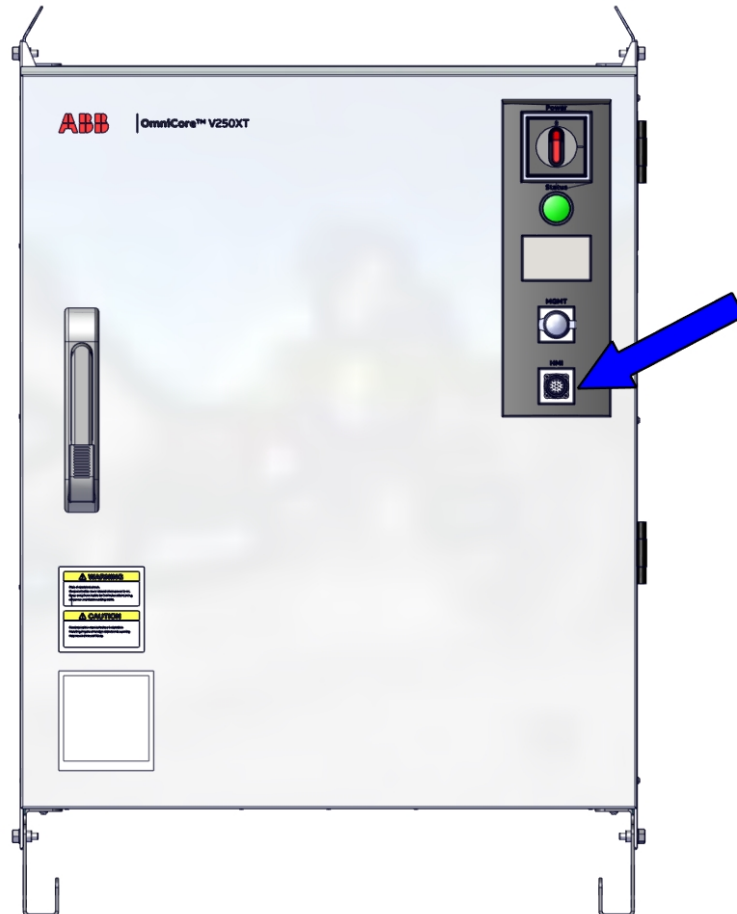

xx2100000829

#### Required spare parts



#### Note

The spare part numbers that are listed in the table can be out of date. See the latest spare parts of the OmniCore V250XT Type B via myABB Business Portal, [www.abb.com/myABB](http://www.abb.com/myABB).

Spare part	Article number	Note
Harness TPU connection	3HAC071006-001	Harness-TPU

Continues on next page

5.3.3 Replacing the HMI signal (FlexPendant) connector  
Continued

Required tools and equipment



Equipment	Article number	Note
Standard toolkit	-	Content is defined in section <a href="#">Standard toolkit for controller on page 436</a> .
ESD protective wrist band	-	

Required documents

Document	Article number	Note
<i>Circuit diagram - OmniCore V250XT</i> , rev 04 or later	3HAC074000-008	

Removing the HMI signal connector

Preparations

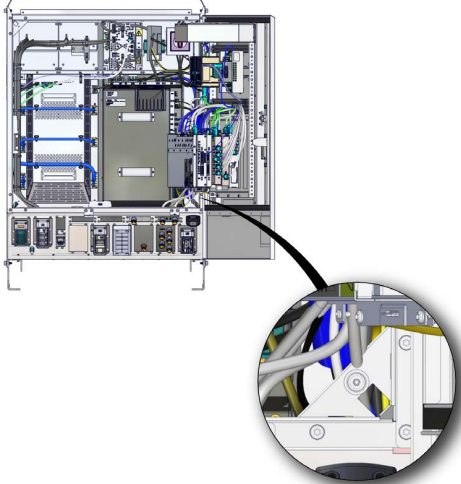
	Action	Note/Illustration
1	 <b>DANGER</b> Before doing any work inside the cabinet, disconnect the mains power. For more information, see <a href="#">Electrical safety on page 29</a> .	
2	Open the door.	<a href="#">Opening the door on page 188</a> .
3	 <b>ELECTROSTATIC DISCHARGE (ESD)</b> The unit is sensitive to ESD. Before handling the unit read the safety information in section <a href="#">The unit is sensitive to ESD on page 45</a> .	Location of wrist strap button:  xx2200001817

Continues on next page

## 5 Repair

### 5.3.3 Replacing the HMI signal (FlexPendant) connector

*Continued*

#### Removing the HMI signal connector

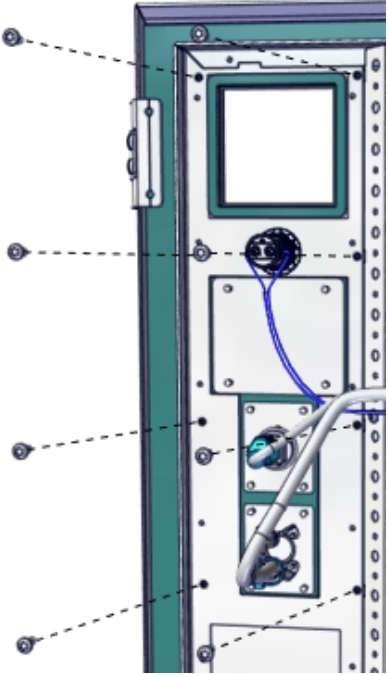
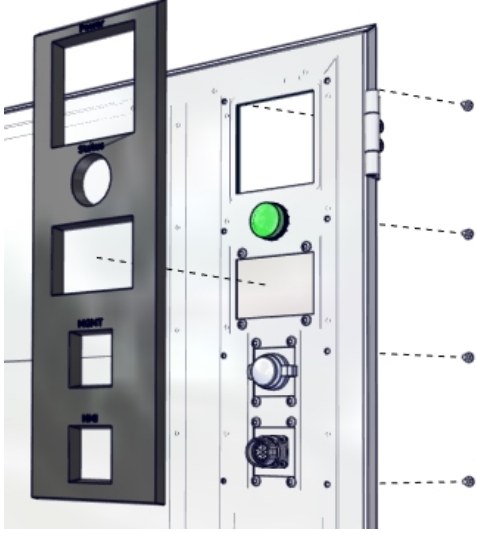
	Action	Note/Illustration
1	<p>Cut the cable ties and remove the cables out from the clips in the cabinet carefully.</p> <p> <b>Note</b></p> <p>Make records about the sequence that cables are removed. The cables need to be installed in the same position.</p>	
2	Disconnect all connectors from the unit to be replaced.	
3	Remove the screws.	 <p>xx210000830</p>
4	Remove the cover plate.	 <p>xx210000831</p>

*Continues on next page*

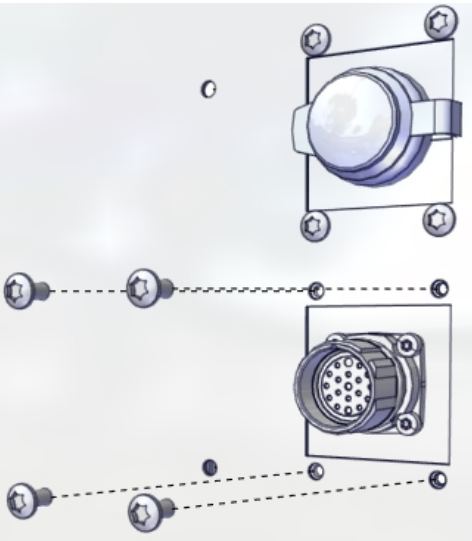

5.3.3 Replacing the HMI signal (FlexPendant) connector

Continued

	Action	Note/Illustration
5	Remove the attachment screws on the door.	 <p>xx2100000832</p>
6	Push the HMI signal connector into the cabinet.	
7	Take out the HMI signal connector.	

Refitting the HMI signal connector

Refitting the HMI signal connector

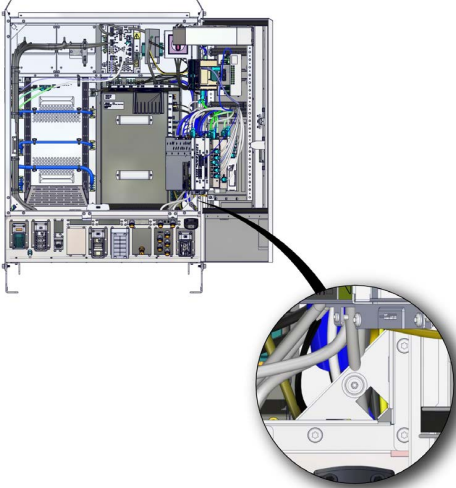

	Action	Note/Illustration
1	 <p><b>DANGER</b></p> <p>Before doing any work inside the cabinet, disconnect the mains power. For more information, see <a href="#">Electrical safety on page 29</a>.</p>	
2	 <p><b>ELECTROSTATIC DISCHARGE (ESD)</b></p> <p>The unit is sensitive to ESD. Before handling the unit read the safety information in section <a href="#">The unit is sensitive to ESD on page 45</a>.</p>	<p>Location of wrist strap button:</p>  <p>xx2200001817</p>

Continues on next page

## 5 Repair

### 5.3.3 Replacing the HMI signal (FlexPendant) connector

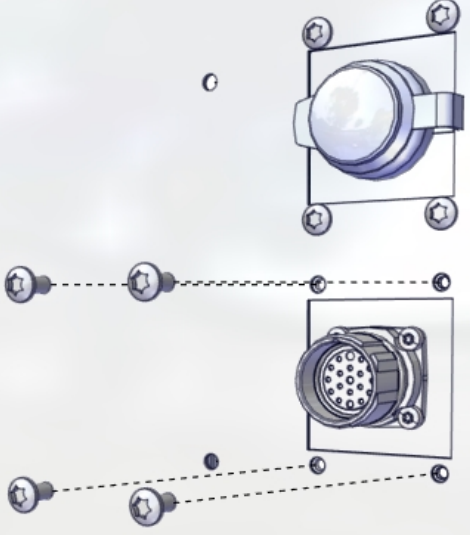
Continued

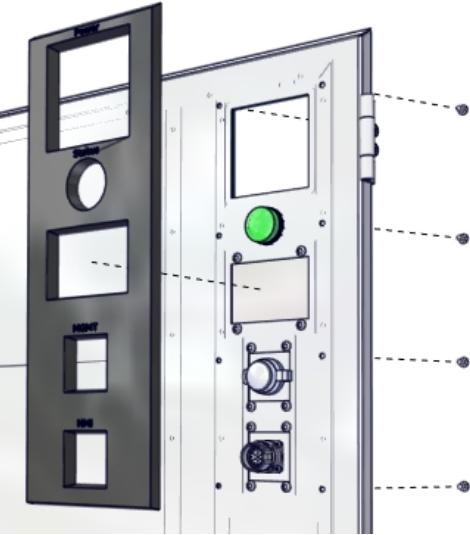
	Action	Note/Illustration
3	Insert the HMI signal connector into the cover from inside the cabinet. Secure it with the screws.	<p>Screws: Torx, countersunk screw M4x10 (4 pcs) Tightening torque: 1.7 Nm±10%.</p>  <p>xx210000832</p>
4	Reconnect any connectors disconnected at removal.	
5	Secure the cables on HMI signal connector with new cable ties.   <b>Tip</b> Use the same position as from removing the HMI signal connector.	
6	Refit the cover plate.	 <p>xx210000831</p>

Continues on next page

5.3.3 Replacing the HMI signal (FlexPendant) connector  
*Continued*

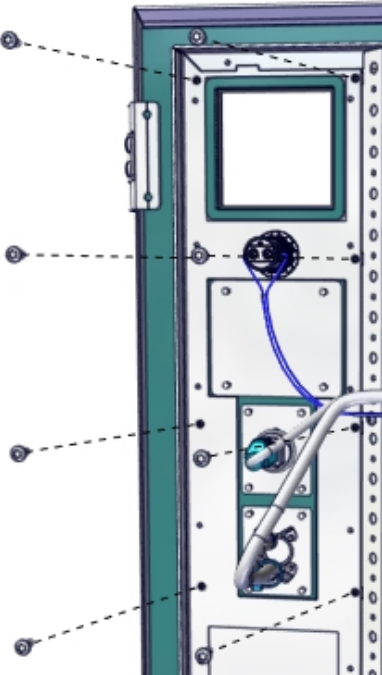
	Action	Note/Illustration
7	Secure it with the screws.	<p>Screws: Torx pan head screw M4x8 (3 pcs)                      Tightening torque: 1.7 Nm±10%.</p>  <p>xx2100000830</p>

Concluding procedure

	Action	Note/Illustration
1	Close the door.	<a href="#">Closing the door on page 189.</a>
2	Perform the function tests to verify that the safety features work properly, see <a href="#">Function tests on page 177.</a>	

## 5 Repair

### 5.3.4 Replacing the cable grommet assembly

### 5.3.4 Replacing the cable grommet assembly

#### Location

The illustration shows the location of the cable grommet assembly on the controller.

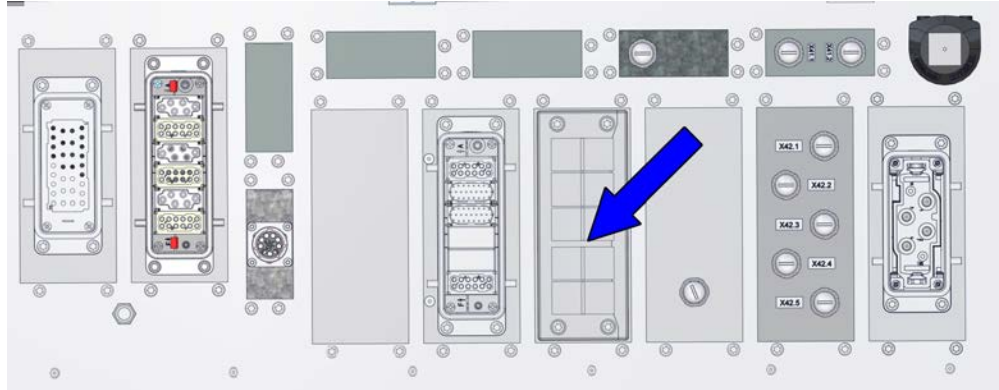

xx2200002163



#### Note

The end user needs to install proper grommets according to the diameter of the cables which need to go through the grommet.

Incorrect use of grommets will affect ingress protection, EMI/EMC and temperature.

It is recommended to use icotek KT grommet.

#### Required spare parts



#### Note

The spare part numbers that are listed in the table can be out of date. See the latest spare parts of the OmniCore V250XT Type B via myABB Business Portal, [www.abb.com/myABB](http://www.abb.com/myABB).

Spare part	Article number	Note
Cable grommet asm	3HAC066396-001	
Harness network connection 2xM12	3HAC084125-001	
Harness network connection 1xM12	3HAC084103-001	
Blind plate	3HAC069954-001	
Harness Ethernet comm. 5xM12	3HAC070894-001	

Continues on next page



5.3.4 Replacing the cable grommet assembly  
Continued

Required tools and equipment



Equipment	Article number	Note
Standard toolkit	-	Content is defined in section <a href="#">Standard toolkit for controller on page 436</a> .
ESD protective wrist band	-	

Required documents

Document	Article number	Note
<i>Circuit diagram - OmniCore V250XT</i> , rev 04 or later	3HAC074000-008	

Removing the cable grommet assembly

Preparations

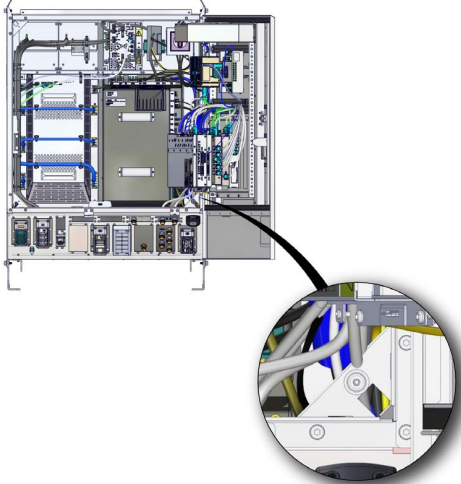
	Action	Note/Illustration
1	 <b>DANGER</b> Before doing any work inside the cabinet, disconnect the mains power. For more information, see <a href="#">Electrical safety on page 29</a> .	
2	Open the door.	<a href="#">Opening the door on page 188</a> .
3	 <b>ELECTROSTATIC DISCHARGE (ESD)</b> The unit is sensitive to ESD. Before handling the unit read the safety information in section <a href="#">The unit is sensitive to ESD on page 45</a> .	Location of wrist strap button: 

xx2200001817

Continues on next page

## 5 Repair

### 5.3.4 Replacing the cable grommet assembly

*Continued*

#### Removing the cable grommet assembly

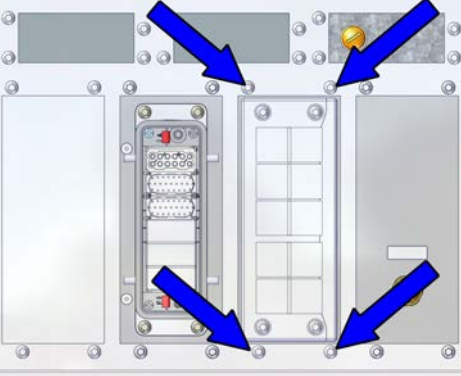
	Action	Note/Illustration
1	Remove the cables out from the clips in the cabinet carefully.   <b>Note</b> Make records about the sequence that cables are removed. The cables need to be installed in the same position.	
2	Remove the attachment screws on the cover.	 xx210000845
3	Push the cable grommet assembly into the cabinet.	
4	Take the cable grommet assembly out.	

#### Releasing the cables from the cable grommet assembly

	Action	Note/Illustration
1	Unscrew the cable entry frame from the enclosure wall.	 xx1900002332

*Continues on next page*

5.3.4 Replacing the cable grommet assembly  
Continued

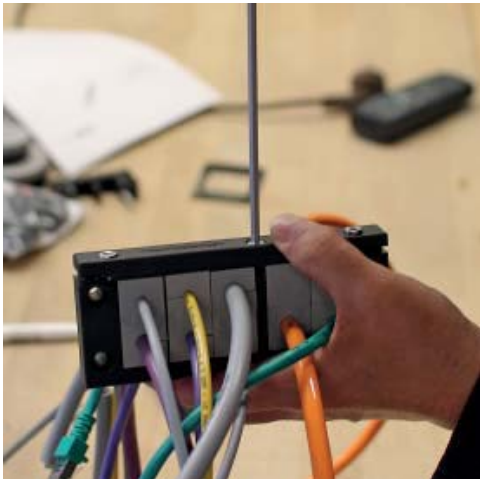
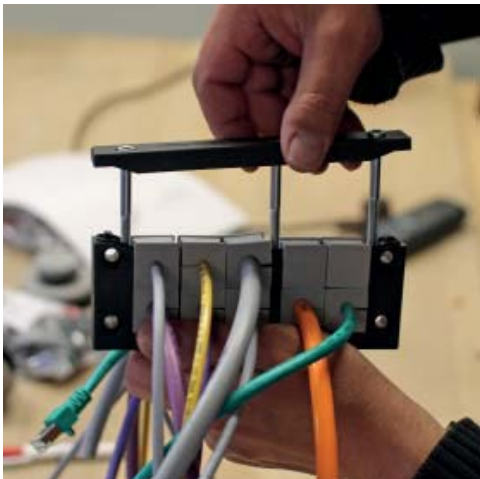

	Action	Note/Illustration
2	Take out the cables with the cable entry frame through the cut-out.	 <p>xx1900002333</p>
3	Remove the attachment screws on the frame and cover strip together.	 <p>xx1900002334</p>
4	Remove the cover strip from the frame.	 <p>xx1900002335</p>

Continues on next page

## 5 Repair

### 5.3.4 Replacing the cable grommet assembly

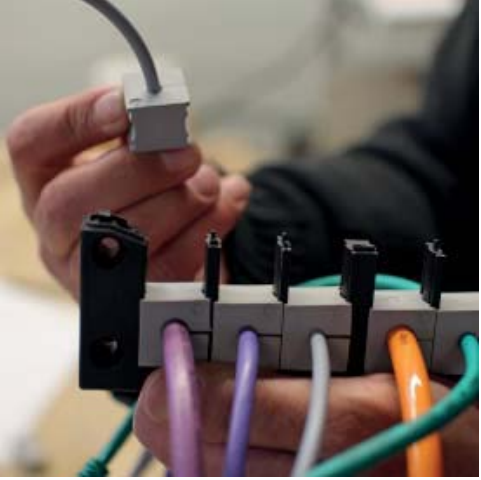

*Continued*

	Action	Note/Illustration
5	<p>Take out the grommets with the cables that need to be removed one by one.</p> <p> <b>Tip</b></p> <p>Remove the grommets in the upper row first and then the second row.</p>	 <p>xx1900002336</p>
6	<p>Remove the cable from the corresponding KT grommet.</p>	 <p>xx1900002337</p>

*Continues on next page*

Refitting the cable grommet assembly

Refitting the cables to the cable grommet assembly

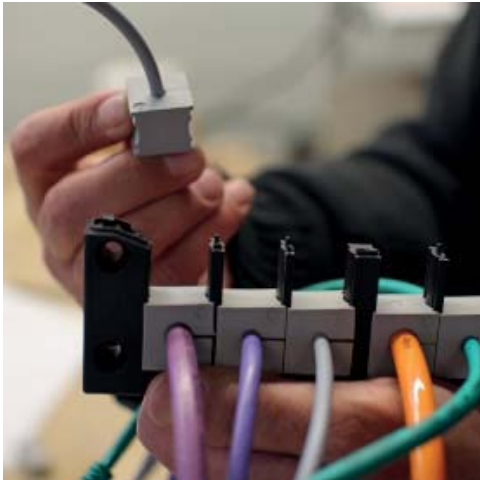
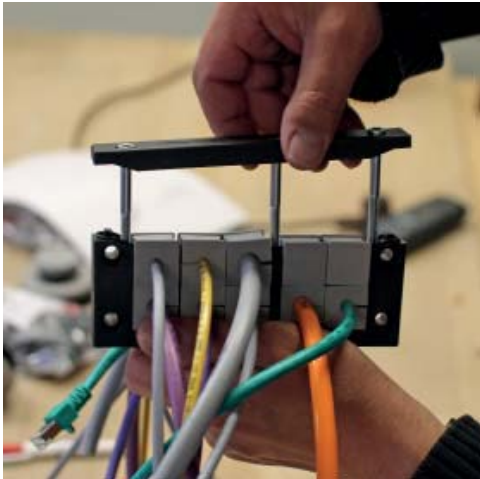

	Action	Note/Illustration
1	Insert and equip the cable to the corresponding KT grommet.	 <p data-bbox="954 907 1061 929">xx1900002337</p>
2	Slide the grommets into the frame halves.   <b>Note</b> It must be ensured that the flat side of the grommets in the lower row are pointing to the open side of the frame half (flat sides pointing upwards).   <b>Note</b> The flat side of the grommets in the upper row have to point downwards so that all flat sides rest on each other. When using single row frames the flat side has to point towards the cover strip.	 <p data-bbox="954 1453 1061 1476">xx1900002336</p>
3	Refit the cover strip onto the frame.	 <p data-bbox="954 1998 1061 2020">xx1900002335</p>

Continues on next page

## 5 Repair

### 5.3.4 Replacing the cable grommet assembly

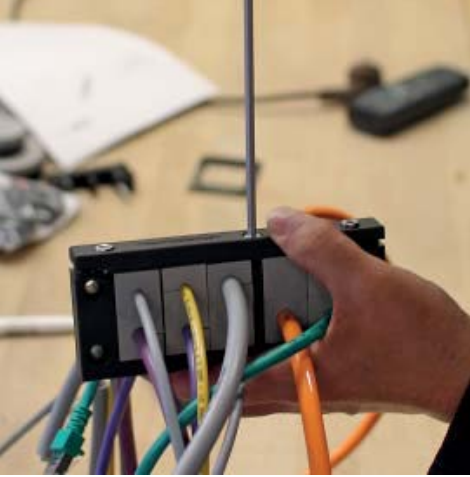
*Continued*



	Action	Note/Illustration
4	Secure the frame and cover strip with the screws.	<p data-bbox="927 315 1398 405">Screws: Hex socket head cap screw M5x50 12.9 Lafre 2C2B/FC6.9 (3 pcs) Tightening torque: 2 Nm - 3 Nm.</p>  <p data-bbox="927 898 1034 920">xx1900002334</p>
5	Route the cables through the cut-out.	 <p data-bbox="927 1442 1034 1464">xx1900002333</p>

*Continues on next page*

5.3.4 Replacing the cable grommet assembly  
Continued

	Action	Note/Illustration
6	Refit the cable entry frame to the enclosure wall and secure with the screws.	<p>Screws: Torx pan head screw M4x8 (4 pcs) Tightening torque: 1.5 Nm.</p>  <p>xx1900002332</p>

Refitting the cable grommet assembly

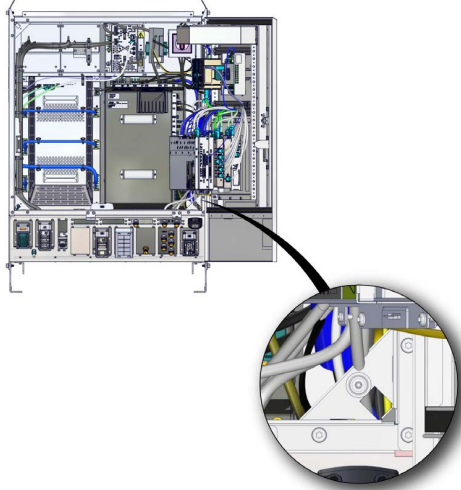
	Action	Note/Illustration
1	 <p><b>DANGER</b></p> <p>Before doing any work inside the cabinet, disconnect the mains power. For more information, see <a href="#">Electrical safety on page 29</a>.</p>	
2	 <p><b>ELECTROSTATIC DISCHARGE (ESD)</b></p> <p>The unit is sensitive to ESD. Before handling the unit read the safety information in section <a href="#">The unit is sensitive to ESD on page 45</a>.</p>	<p>Location of wrist strap button:</p>  <p>xx2200001817</p>

Continues on next page



## 5 Repair

### 5.3.4 Replacing the cable grommet assembly

*Continued*

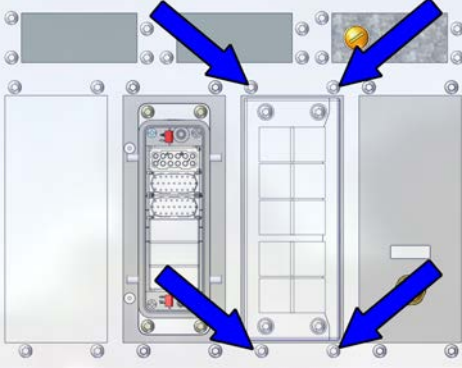
	Action	Note/Illustration
3	Insert the cable grommet assembly into the cover of the cabinet. Secure it with the screws.	Screws: Torx pan head screw M4x8 (4 pcs)  xx2100000845

#### Concluding procedure

	Action	Note/Illustration
1	Close the door.	<a href="#">Closing the door on page 189.</a>
2	Perform the function tests to verify that the safety features work properly, see <a href="#">Function tests on page 177.</a>	



### 5.3.5 Replacing the Ethernet outlet connector with cable

#### Location

The illustration shows the location of the Ethernet outlet connector with cable.



xx210000849

#### Required spare parts



#### Note

The spare part numbers that are listed in the table can be out of date. See the latest spare parts of the OmniCore V250XT Type B via myABB Business Portal, [www.abb.com/myABB](http://www.abb.com/myABB).

Spare part	Article number	Note
Ethernet Harness	3HAC084151-001	

*Continues on next page*

## 5 Repair

### 5.3.5 Replacing the Ethernet outlet connector with cable

*Continued*

#### Required tools and equipment



Equipment	Article number	Note
Standard toolkit	-	Content is defined in section <a href="#">Standard toolkit for controller on page 436</a> .
ESD protective wrist band	-	

#### Required documents

Document	Article number	Note
<i>Circuit diagram - OmniCore V250XT</i> , rev 04 or later	3HAC074000-008	

#### Removing the Ethernet outlet connector with cable

##### Preparations

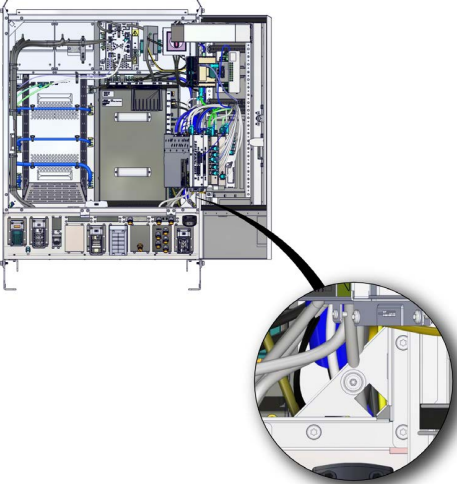
	Action	Note/Illustration
1	 <b>DANGER</b> Before doing any work inside the cabinet, disconnect the mains power. For more information, see <a href="#">Electrical safety on page 29</a> .	
2	Open the door.	<a href="#">Opening the door on page 188</a> .
3	 <b>ELECTROSTATIC DISCHARGE (ESD)</b> The unit is sensitive to ESD. Before handling the unit read the safety information in section <a href="#">The unit is sensitive to ESD on page 45</a> .	Location of wrist strap button:  xx2200001817

*Continues on next page*

5.3.5 Replacing the Ethernet outlet connector with cable  
*Continued*

Removing the Ethernet outlet connector with cable

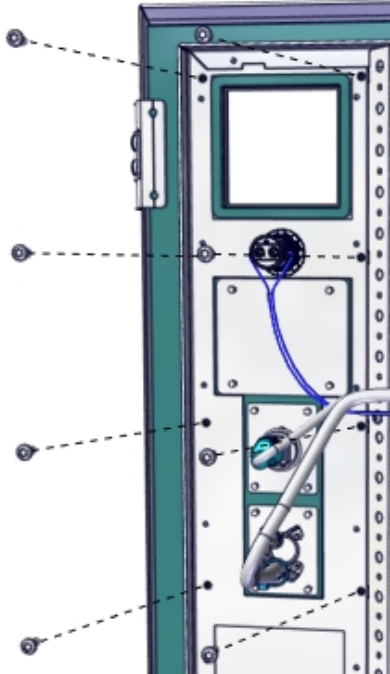
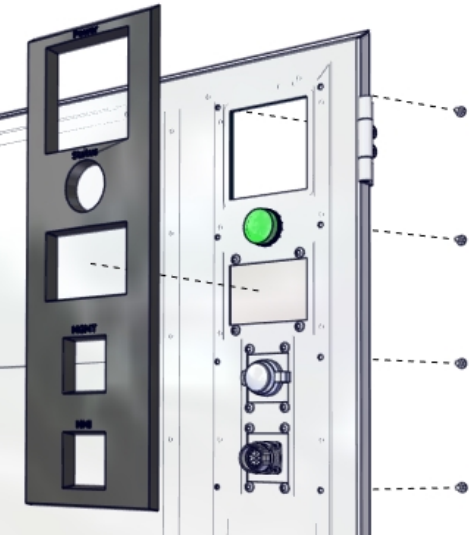

	Action	Note/Illustration
1	Remove the screws.	 <p>xx210000830</p>
2	Remove the cover plate.	 <p>xx210000831</p>

*Continues on next page*

## 5 Repair

### 5.3.5 Replacing the Ethernet outlet connector with cable

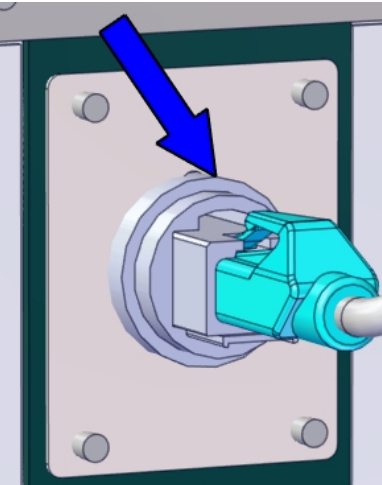
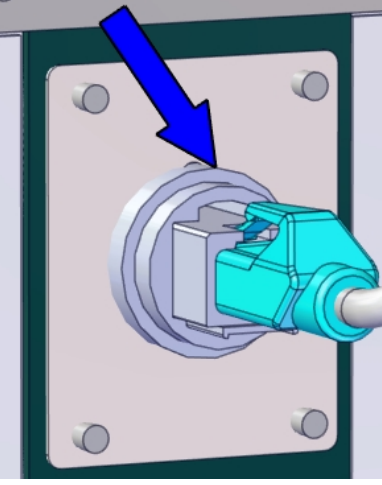



Continued

	Action	Note/Illustration
3	Remove the attachment screws on the door.	 xx210000852
4	Turn the locking ring anti-clockwise to remove the connector.	 xx210000852
5	Push the Ethernet outlet connector with cable into the cabinet.	
6	Disconnect all connectors from the unit to be replaced.	
7	Remove the cables out from the clips in the cabinet carefully.   <b>Note</b> Make records about the sequence that cables are removed. The cables need to be installed in the same position.	
8	Take the Ethernet outlet connector with cable out from the upper side.	

Continues on next page

Refitting the Ethernet outlet connector with cable

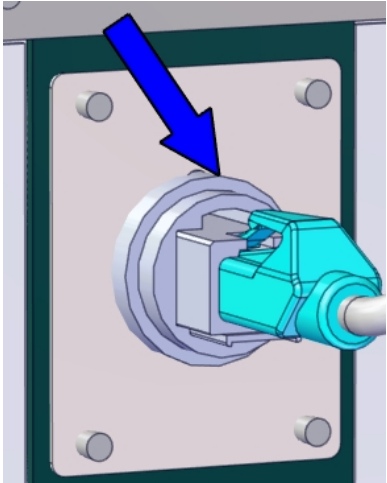
Refitting the Ethernet outlet connector with cable

	Action	Note/Illustration
1	 <b>DANGER</b> Before doing any work inside the cabinet, disconnect the mains power. For more information, see <a href="#">Electrical safety on page 29</a> .	
2	 <b>ELECTROSTATIC DISCHARGE (ESD)</b> The unit is sensitive to ESD. Before handling the unit read the safety information in section <a href="#">The unit is sensitive to ESD on page 45</a> .	
3	Insert the Ethernet outlet connector with cable into the cover from inner side of the cabinet.	
4	Secure it with the locking ring.	 xx2100000852
5	Reconnect any connectors disconnected at removal.	
6	Secure the Ethernet outlet connector with cables with the clips on the cabinet.   <b>Tip</b> Use the same position as from removing the harness ETH outlet with cable.	

Concluding procedure

	Action	Note/Illustration
1	Close the door.	<a href="#">Closing the door on page 189</a> .

Continues on next page

## 5 Repair

---

### 5.3.5 Replacing the Ethernet outlet connector with cable

*Continued*

	Action	Note/Illustration
2	Perform the function tests to verify that the safety features work properly, see <a href="#">Function tests on page 177</a> .	

5.3.6 Replacing the LED indicator

Location

The illustration shows the location of the LED indicator.



xx210000505

Required spare parts



Note

The spare part numbers that are listed in the table can be out of date. See the latest spare parts of the OmniCore V250XT Type B via myABB Business Portal, [www.abb.com/myABB](http://www.abb.com/myABB).

Spare part	Article number	Note
LED indicator	3HAC065549-001	

Continues on next page

## 5 Repair

### 5.3.6 Replacing the LED indicator

*Continued*

#### Required tools and equipment



Equipment	Article number	Note
Standard toolkit	-	Content is defined in section <a href="#">Standard toolkit for controller on page 436</a> .
ESD protective wrist band	-	

#### Required documents

Document	Article number	Note
<i>Circuit diagram - OmniCore V250XT</i> , rev 04 or later	3HAC074000-008	

#### Removing the LED indicator

##### Preparations

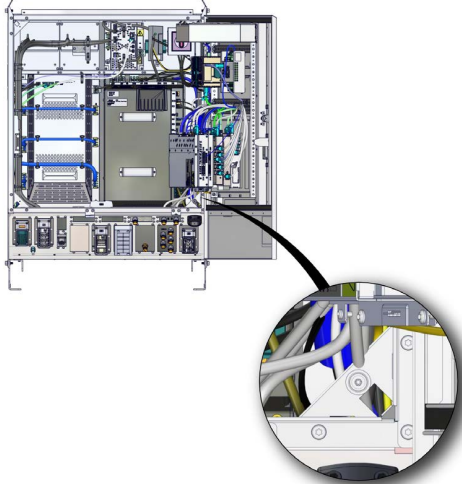
	Action	Note/Illustration
1	 <b>DANGER</b> Before doing any work inside the cabinet, disconnect the mains power. For more information, see <a href="#">Electrical safety on page 29</a> .	
2	Open the door.	<a href="#">Opening the door on page 188</a> .
3	 <b>ELECTROSTATIC DISCHARGE (ESD)</b> The unit is sensitive to ESD. Before handling the unit read the safety information in section <a href="#">The unit is sensitive to ESD on page 45</a> .	Location of wrist strap button:  xx2200001817

*Continues on next page*



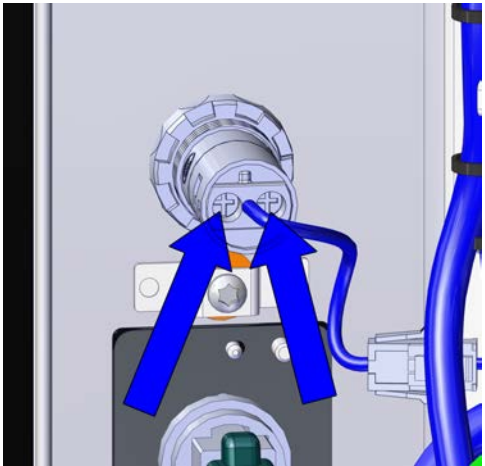

Removing the LED indicator

	Action	Note/Illustration
1	Loose the attachment screws locking the cable.	 <p>xx1900001926</p>
2	Remove the terminals (X1&X2) of the cable from the lamp.	
3	Turn the MON_LAMP screw anti-clockwise to remove the screw.	
4	Take the LED indicator out.	

Refitting the LED indicator

Refitting the LED indicator

	Action	Note/Illustration
1	 <p><b>DANGER</b></p> <p>Before doing any work inside the cabinet, disconnect the mains power. For more information, see <a href="#">Electrical safety on page 29</a>.</p>	
2	 <p><b>ELECTROSTATIC DISCHARGE (ESD)</b></p> <p>The unit is sensitive to ESD. Before handling the unit read the safety information in section <a href="#">The unit is sensitive to ESD on page 45</a>.</p>	
3	Insert the LED indicator into the cover from outer side of the door and the screw from inner side and screw them up.	

Continues on next page

## 5 Repair

### 5.3.6 Replacing the LED indicator

*Continued*

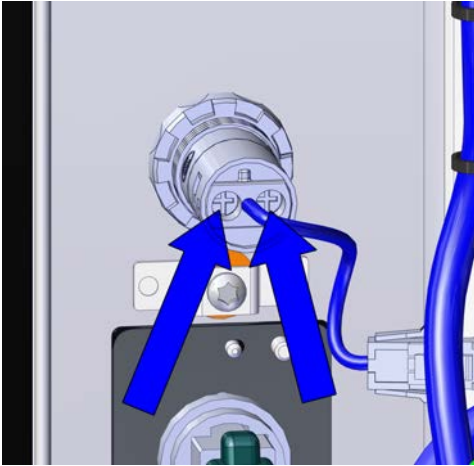
	Action	Note/Illustration
4	Insert the terminals (X1 & X2) of cables into the lamp and secure with the screws.	 <p>xx1900001926</p>

#### Concluding procedure

	Action	Note/Illustration
1	Close the door.	<a href="#">Closing the door on page 189.</a>
2	Perform the function tests to verify that the safety features work properly, see <a href="#">Function tests on page 177.</a>	

### 5.3.7 Replacing the door lock insert

#### Location

The illustration shows the location of the door lock.

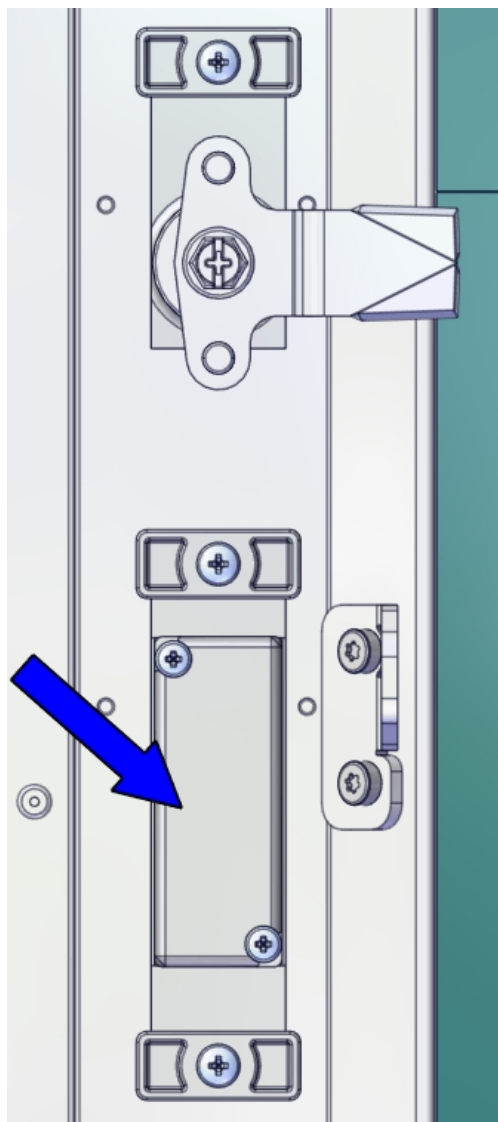

xx240000104

#### Required spare parts



#### Note

The spare part numbers that are listed in the table can be out of date. See the latest spare parts of the OmniCore V250XT Type B via myABB Business Portal, [www.abb.com/myABB](http://www.abb.com/myABB).

Spare part	Article number	Note
Key	3HAC074600-001	Square 6 mm

*Continues on next page*

## 5 Repair

### 5.3.7 Replacing the door lock insert

*Continued*

Spare part	Article number	Note
Lock insert	3HAC025309-004	Double bit 3
Lock insert	3HAC025309-005	Slot 1, 2 x 3
Lock insert	3HAC025309-007	Triangular 6,5 CNOMO
Lock insert	3HAC025309-008	Cylinder E1

#### Required tools and equipment

Equipment	Article number	Note
Standard toolkit	-	Content is defined in section <a href="#">Standard toolkit for controller on page 436</a> .
ESD protective wrist band	-	

#### Required documents

Document	Article number	Note
<i>Circuit diagram - OmniCore V250XT</i> , rev 04 or later	3HAC074000-008	

#### Removing the lock insert

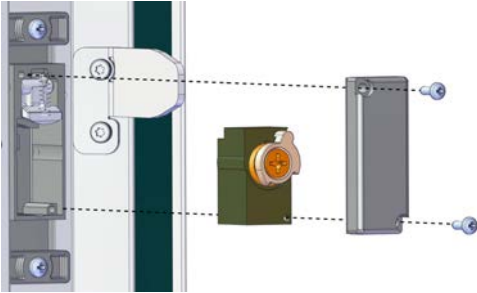
	Action	Note/Illustration
1	 <b>DANGER</b> Before doing any work inside the cabinet, disconnect the mains power. For more information, see <a href="#">Electrical safety on page 29</a> .	
2	Open the door.	<a href="#">Opening the door on page 188</a> .
3	Remove the two screws and lift off the cover.	 xx240000101
4	Remove the lock insert.	

*Continues on next page*

Refitting the lock insert

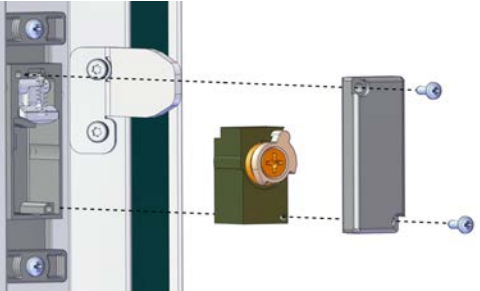
	Action	Note/Illustration
1	<p> <b>DANGER</b></p> <p>Before doing any work inside the cabinet, disconnect the mains power. For more information, see <a href="#">Electrical safety on page 29</a>.</p>	
2	Put the lock insert in place.	
3	Refit the cover and tighten the two screws.	 <p>xx2400000101</p> <p>Tightening torque: 2 Nm</p>
4	Close the door.	<a href="#">Closing the door on page 189</a> .
5	Perform the function tests to verify that the safety features work properly, see <a href="#">Function tests on page 177</a> .	

## 5 Repair

### 5.4.1 Replacing the power cable and power cable cover

## 5.4 Replacing parts on the FlexPendant

### 5.4.1 Replacing the power cable and power cable cover

#### Location

The illustration shows the location of the power cable, power cable gasket, and power cable cover in the FlexPendant.

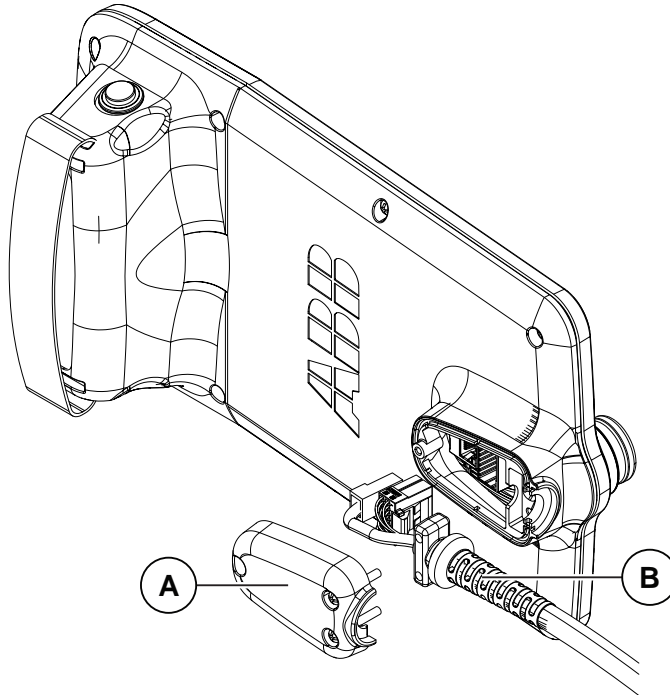

xx1800001154

A	Power cable cover
B	Power cable

#### Required spare parts



#### Note

The spare part numbers that are listed in the table can be out of date. See the latest spare parts of the OmniCore V250XT Type B via myABB Business Portal, [www.abb.com/myABB](http://www.abb.com/myABB).

Spare part	Article number	Note
FlexPendant	3HAC086996-001	DSQC3124
Power cable cover	3HAC065401-001	
FlexPendant power cable 3 m	3HAC064448-002	
FlexPendant power cable 10 m	3HAC064448-001	

*Continues on next page*

5.4.1 Replacing the power cable and power cable cover

Continued

Required tools and equipment

Equipment	Article number	Note
Standard toolkit	-	Content is defined in section <a href="#">Standard toolkit for controller on page 436</a> .
ESD protective wrist band	-	

Required documents

Document	Article number	Note
<i>Circuit diagram - OmniCore V250XT</i> , rev 04 or later	3HAC074000-008	

Removing the power cable and power cable cover

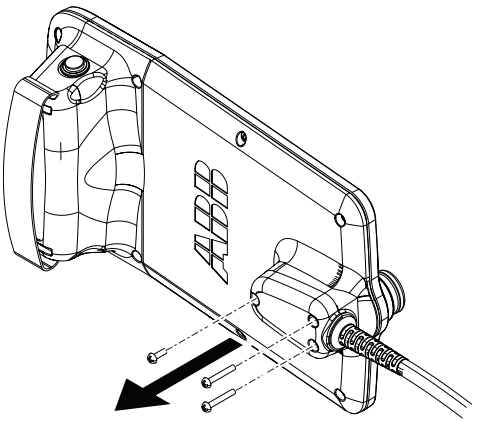
	Action	Note/Illustration
1	 <b>ELECTROSTATIC DISCHARGE (ESD)</b> The unit is sensitive to ESD. Before handling the unit read the safety information in section <a href="#">The unit is sensitive to ESD on page 45</a> .	
2	Disconnect the FlexPendant from the controller.	
3	Remove the attachment screws for the power cable cover.	 <p>xx1800001189</p>

Continues on next page

## 5 Repair

### 5.4.1 Replacing the power cable and power cable cover

*Continued*

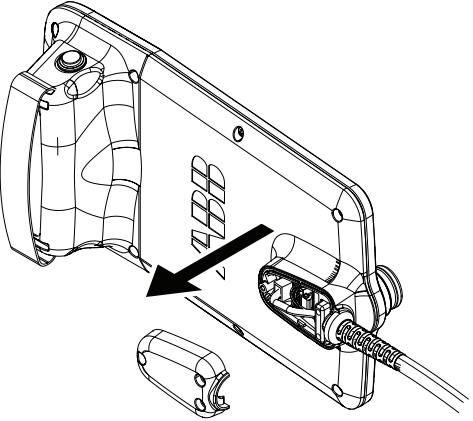
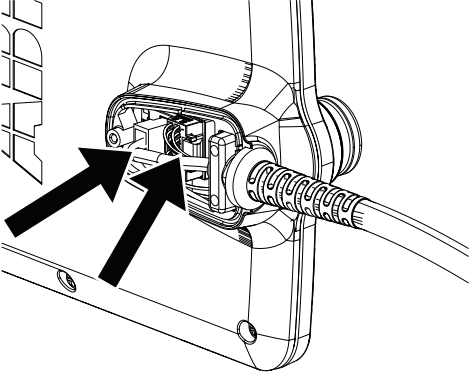
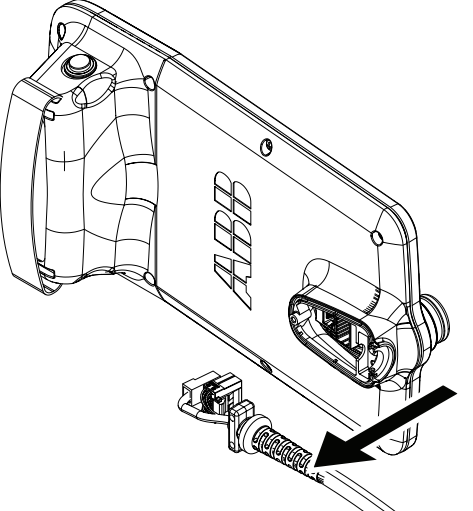
	Action	Note/Illustration
4	Remove the power cable cover.	 <p>xx1800001190</p>
5	Disconnect two connectors to the FlexPendant.	 <p>xx1800001748</p>
6	Remove the power cable.	 <p>xx1800001192</p>

*Continues on next page*

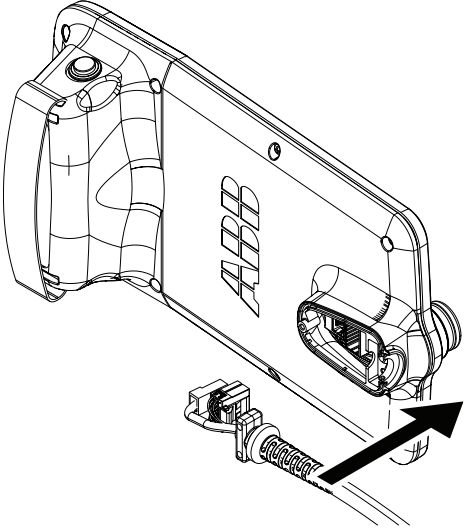
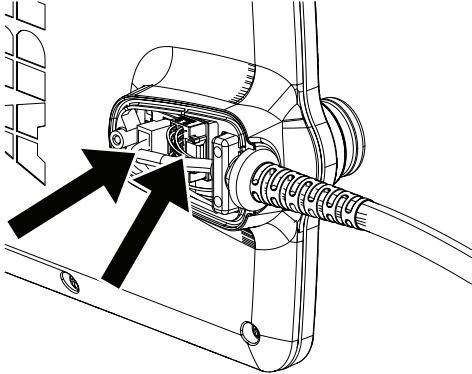

Refitting the power cable and power cable cover

	Action	Note/Illustration
1	 <p><b>ELECTROSTATIC DISCHARGE (ESD)</b></p> <p>The unit is sensitive to ESD. Before handling the unit read the safety information in section <i>The unit is sensitive to ESD on page 45</i>.</p>	
2	<p>Refit the power cable.</p>	 <p>xx1800001193</p>
3	<p>Reconnect the power cable to the Flex-Pendant.</p>	 <p>xx1800001748</p>

Continues on next page

## 5 Repair

### 5.4.1 Replacing the power cable and power cable cover

*Continued*

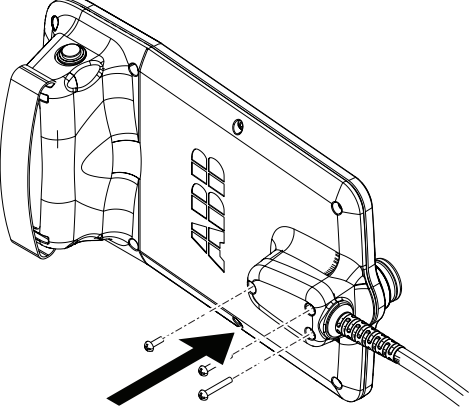
	Action	Note/Illustration
4	Refit the power cable cover and tighten the screws.	<p data-bbox="927 320 1398 349">Screws: Torx pan head screw M4x8 (3 pcs)</p>  <p data-bbox="927 770 1031 790">xx1800001196</p>
5	Perform the function tests to verify that the safety features work properly, see <a href="#">Function tests on page 177</a> .	

## 5.4.2 Replacing the joystick protection

### Location

The illustration shows the location of the joystick protection on the FlexPendant.

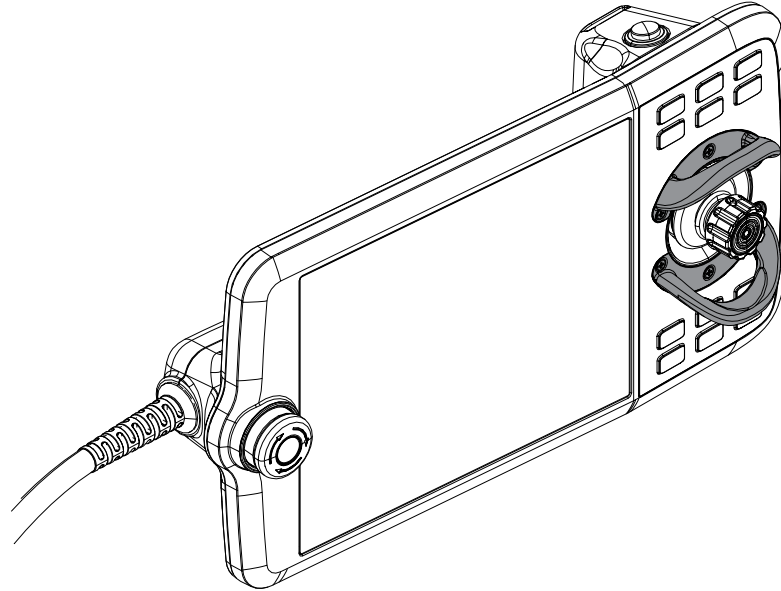

xx1800001197

### Required spare parts



#### Note

The spare part numbers that are listed in the table can be out of date. See the latest spare parts of the OmniCore V250XT Type B via myABB Business Portal, [www.abb.com/myABB](http://www.abb.com/myABB).

Spare part	Article number	Note
Joystick guard	3HAC065408-001	

### Required tools and equipment

Equipment	Article number	Note
Standard toolkit	-	Content is defined in section <a href="#">Standard toolkit for controller on page 436</a> .

### Required documents

Document	Article number	Note
<i>Circuit diagram - OmniCore V250XT, rev 04 or later</i>	3HAC074000-008	

Continues on next page

## 5 Repair

### 5.4.2 Replacing the joystick protection

Continued

#### Removing the joystick protection

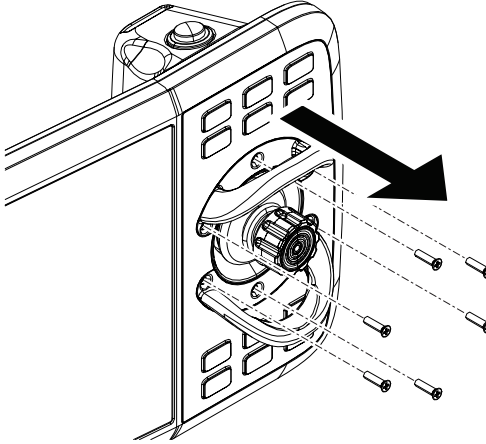
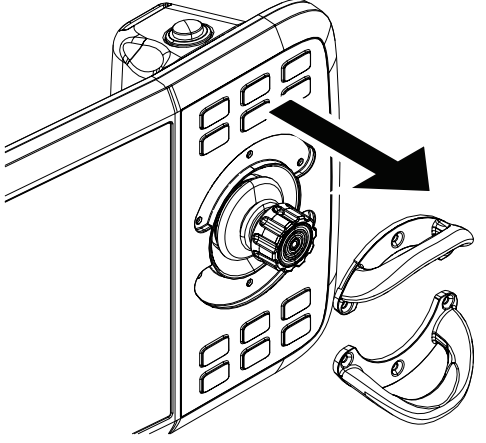
	Action	Note/Illustration
1	 <b>ELECTROSTATIC DISCHARGE (ESD)</b> The unit is sensitive to ESD. Before handling the unit read the safety information in section <i>The unit is sensitive to ESD on page 45</i> .	
2	Disconnect the FlexPendant from the controller.	
3	Remove the attachment screws.	 xx1800001198
4	Remove the joystick protection.	 xx1800001199

#### Refitting the joystick protection

	Action	Note/Illustration
1	 <b>ELECTROSTATIC DISCHARGE (ESD)</b> The unit is sensitive to ESD. Before handling the unit read the safety information in section <i>The unit is sensitive to ESD on page 45</i> .	

Continues on next page

5.4.2 Replacing the joystick protection  
Continued

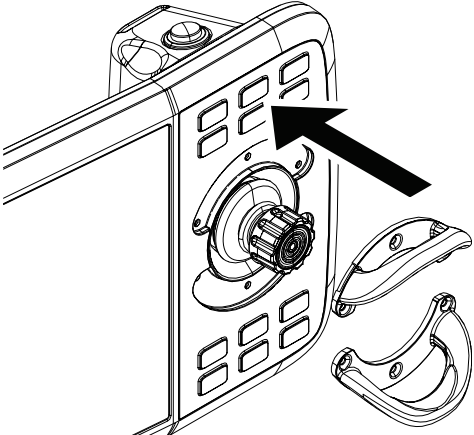
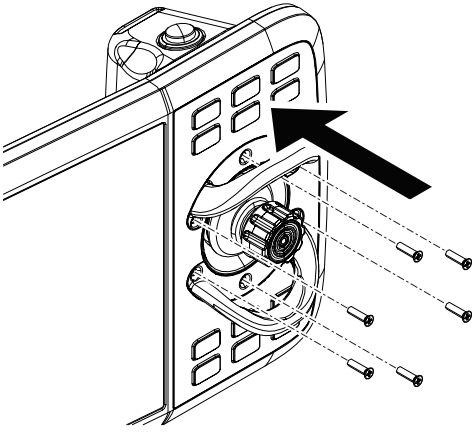
	Action	Note/Illustration
2	Refit the joystick protection.	 <p>xx1800001200</p>
3	Secure the screws.	 <p>xx1800001206</p> <p>Countersunk head screw: ST2.9 X 10 (6 pcs)</p>

## 5 Repair

### 5.4.3 Replacing the fasten strip

### 5.4.3 Replacing the fasten strip

#### Location

The illustration shows the location of the fasten strip on the FlexPendant.

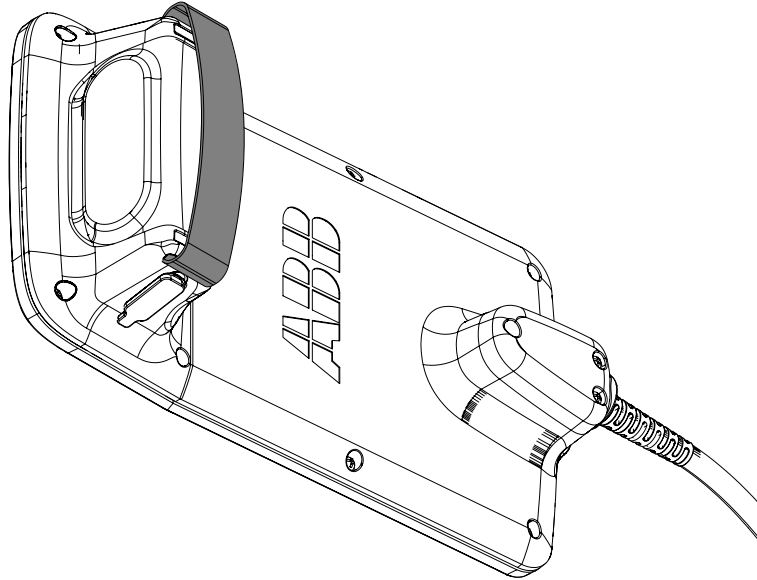

xx1900000771

#### Required spare parts



#### Note

The spare part numbers that are listed in the table can be out of date. See the latest spare parts of the OmniCore V250XT Type B via myABB Business Portal, [www.abb.com/myABB](http://www.abb.com/myABB).

Spare part	Article number	Note
Fasten strip	3HAC065419-001	

#### Replacing the fasten strip

	Action	Note/Illustration
1	Open the velcro on the fasten strip.	
2	Take the fasten strip out from the holes.	
3	Insert the new fasten strip into the holes one by one.	
4	Secure the velcro in a suitable length.	

## 5.5 Replacing other parts

### 5.5.1 Replacing the motor connection box

#### Location

The motor connection box location is decided by the customer.

#### Required spare parts



#### Note

The spare part numbers that are listed in the table can be out of date. See the latest spare parts of the OmniCore V250XT Type B via myABB Business Portal, [www.abb.com/myABB](http://www.abb.com/myABB).

Spare part	Article number	Note
Motor Connection Box	3HAC087717-001	3-axis
Motor Connection Box	3HAC087718-001	3-axis, BRB
Motor Connection Box	3HAC087719-001	6-axis
Motor Connection Box	3HAC087720-001	6-axis, BRB

#### Required tools and equipment

Equipment	Article number	Note
Standard toolkit	-	Content is defined in section <a href="#">Standard toolkit for controller on page 436</a> .
ESD protective wrist band	-	

#### Required documents

Document	Article number	Note
<i>Circuit diagram - OmniCore V250XT</i> , rev 04 or later	3HAC074000-008	

#### Removing the motor connection box

	Action	Note/Illustration
1	<b>DANGER</b> Before doing any work inside the cabinet, disconnect the mains power. For more information, see <a href="#">Electrical safety on page 29</a> .	
2	Disconnect all connectors from the unit to be replaced.	

Continues on next page

## 5 Repair

---

### 5.5.1 Replacing the motor connection box

*Continued*

---

#### Refitting the motor connection box

	Action	Note/Illustration
1	 <b>DANGER</b> Before doing any work inside the cabinet, disconnect the mains power. For more information, see <a href="#">Electrical safety on page 29</a> .	
2	Reconnect any connectors disconnected at removal.	
3	Perform the function tests to verify that the safety features work properly, see <a href="#">Function tests on page 177</a> .	



## 5.5.2 Replacing the measurement unit

### Location

The illustration shows the location of the measurement unit in the motor connection box.

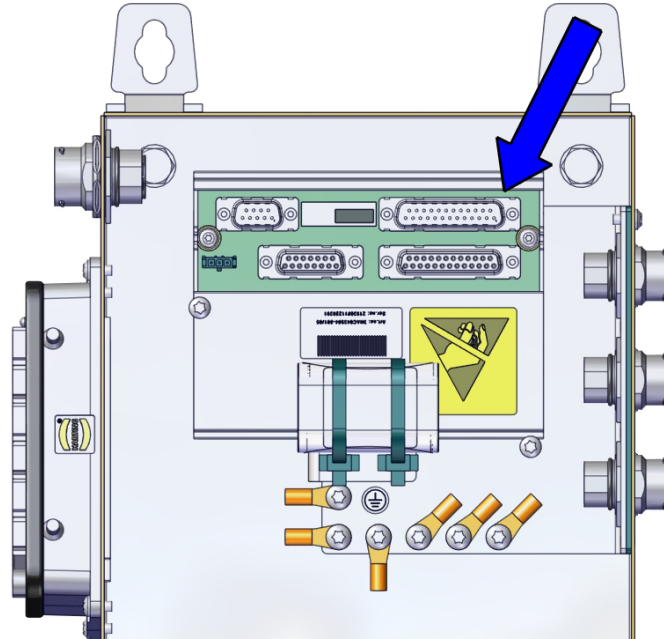

xx2300001700

### Required spare parts



#### Note

The spare part numbers that are listed in the table can be out of date. See the latest spare parts of the OmniCore V250XT Type B via myABB Business Portal, [www.abb.com/myABB](http://www.abb.com/myABB).

Spare part	Article number	Note
Measurement Unit	3HAC043904-001	DSQC633C

### Required tools and equipment

Equipment	Article number	Note
Standard toolkit	-	Content is defined in section <a href="#">Standard toolkit for controller on page 436</a> .
ESD protective wrist band	-	

*Continues on next page*

## 5 Repair



### 5.5.2 Replacing the measurement unit

*Continued*

#### Required documents

Document	Article number	Note
Circuit diagram - OmniCore V250XT, rev 04 or later	3HAC074000-008	

#### Removing the measurement unit

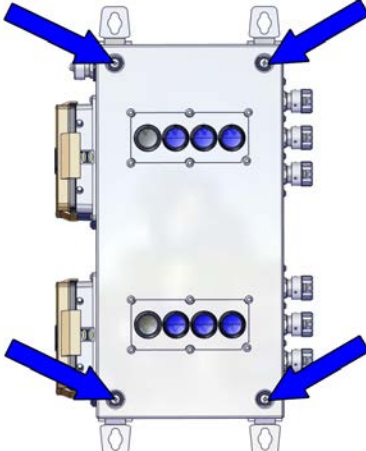
	Action	Note/Illustration
1	 <b>ELECTROSTATIC DISCHARGE (ESD)</b> The unit is sensitive to ESD. Before handling the unit read the safety information in section <i>The unit is sensitive to ESD on page 45</i> .	
2	 <b>DANGER</b> Turn off all: <ul style="list-style-type: none"> <li>• electric power supply</li> <li>• hydraulic pressure supply</li> <li>• air pressure supply</li> </ul> to the robot, before entering the safeguarded space.	
3	 <b>DANGER</b> Before doing any work inside the cabinet, disconnect the mains power. For more information, see <i>Electrical safety on page 29</i> .	
4	Remove the screws holding the cover.	 xx2300001703

*Continues on next page*

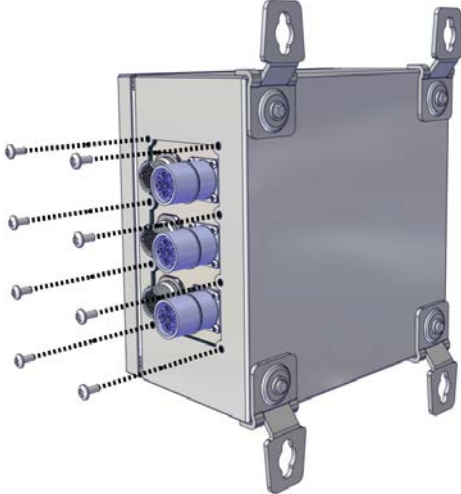
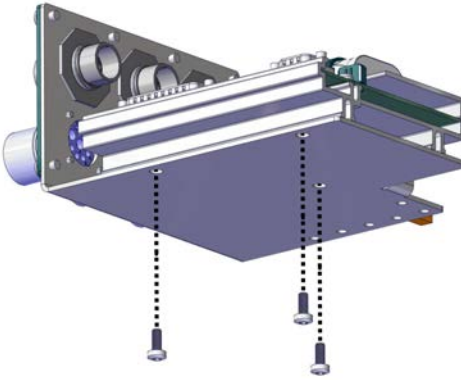
	Action	Note/Illustration
5	<p>Open the cover.</p> <p> <b>CAUTION</b></p> <p>Clean cover from metal residues before opening.</p> <p>Metal residues can cause shortage on the boards which can result in hazardous failures.</p>	
6	<p>Disconnect all connectors from the unit to be replaced.</p>	
7	<p>Remove the screws at the front of the box.</p>	 <p>xx2300001705</p>
8	<p>Push the measurement unit inwards and lift out of the box.</p>	
9	<p>Remove the attachment screws from the mounting plate.</p>	 <p>xx2300001706</p>
10	<p>Pull out the measurement unit.</p>	

Continues on next page

## 5 Repair

### 5.5.2 Replacing the measurement unit

*Continued*

#### Refitting the measurement unit

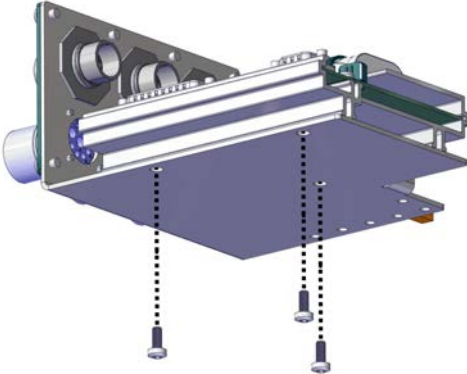
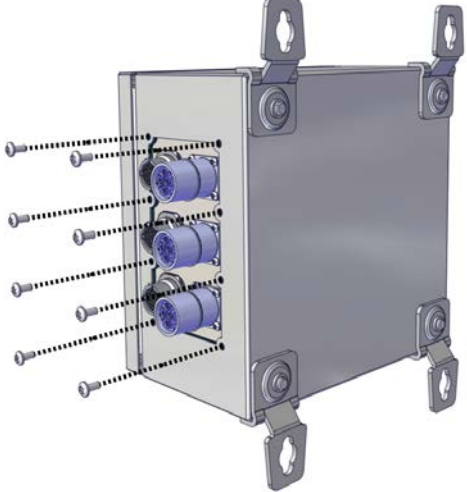
	Action	Note/Illustration
1	Refit the measurement unit on the mounting plate and tighten the screws.	 <p>xx2300001706</p>
2	Put the measurement unit and mounting plate in the box.	
3	Refit the screws at the front of the box.	 <p>xx2300001705</p>
4	Reconnect any connectors disconnected at removal.	

*Continues on next page*

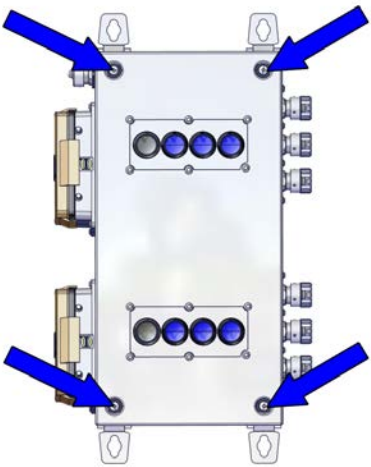
	Action	Note/Illustration
5	Refit the cover.	 <p>xx2300001703</p>
6	Perform the function tests to verify that the safety features work properly, see <a href="#">Function tests on page 177</a> .	

## 5 Repair

### 5.5.3 Replacing the motor connection box battery

### 5.5.3 Replacing the motor connection box battery

#### Location

The illustration shows the location of the main computer in the motor connection box.

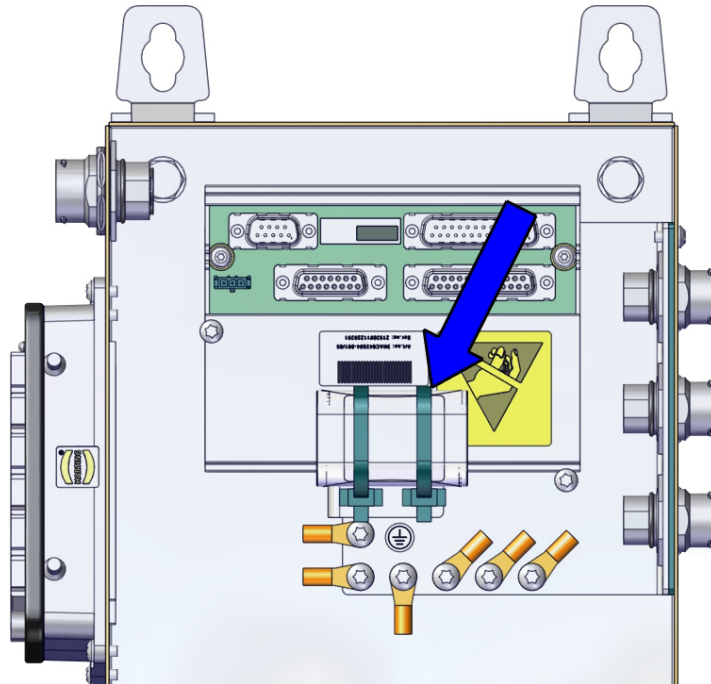

xx2300001707

#### Required spare parts



#### Note

The spare part numbers that are listed in the table can be out of date. See the latest spare parts of the OmniCore V250XT Type B via myABB Business Portal, [www.abb.com/myABB](http://www.abb.com/myABB).

Spare part	Article number	Note
Battery Unit	3HAC044075-001	

#### Required tools and equipment

Equipment	Article number	Note
Standard toolkit	-	Content is defined in section <a href="#">Standard toolkit for controller on page 436</a> .
ESD protective wrist band	-	

*Continues on next page*

5.5.3 Replacing the motor connection box battery  
Continued

## Required documents

Document	Article number	Note
Circuit diagram - OmniCore V250XT, rev 04 or later	3HAC074000-008	

## Removing the motor connection box battery

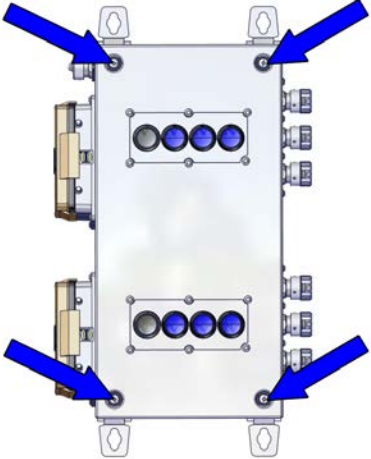
	Action	Note/Illustration
1	 <b>DANGER</b> Before doing any work inside the cabinet, disconnect the mains power. For more information, see <a href="#">Electrical safety on page 29</a> .	
2	Remove the screws holding the cover.	 xx2300001703
3	Remove cable ties from battery.	
4	Disconnect all connectors from the unit to be replaced.	
5	Remove the battery.	

## Refitting the motor connection box battery

	Action	Note/Illustration
1	Refit the battery and secure with cable ties.	
2	Reconnect any connectors disconnected at removal.	

Continues on next page

## 5 Repair

### 5.5.3 Replacing the motor connection box battery

*Continued*

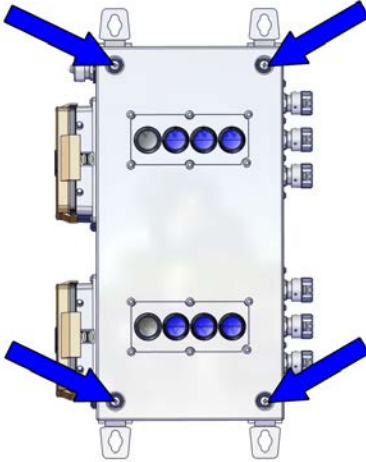
	Action	Note/Illustration
3	Refit the cover.	 <p>xx2300001703</p>
4	Perform the function tests to verify that the safety features work properly, see <a href="#">Function tests on page 177</a> .	



## 6 Decommissioning

### 6.1 Introduction to decommissioning

#### Introduction

This section contains information to consider when taking a product, robot or controller, out of operation.

It deals with how to handle potentially dangerous components and potentially hazardous materials.



#### Note

The decommissioning process shall be preceded by a risk assessment.

#### Disposal of materials used in the robot

All used grease/oils and dead batteries **must** be disposed of in accordance with the current legislation of the country in which the robot and the control unit are installed.

If the robot or the control unit is partially or completely disposed of, the various parts **must** be grouped together according to their nature (which is all iron together and all plastic together), and disposed of accordingly. These parts **must** also be disposed of in accordance with the current legislation of the country in which the robot and control unit are installed.

See also [Environmental information on page 350](#).

#### Disposal of storage media

Before disposal of any storage equipment (anything from an SD card to a complete controller), make sure that all sensitive information has been deleted.



#### Tip

To remove all data from the OmniCore controller, use the **Delete user data** function (part of **Delete RobotWare system** function) in RobotWare. See *Operating manual - Integrator's guide OmniCore*.

#### Transportation

Prepare the robot or parts before transport, this to avoid hazards.

## 6 Decommissioning

---

### 6.2 Environmental information

## 6.2 Environmental information

---

### Introduction

ABB robots contain components in different materials. During decommissioning, all materials should be dismantled, recycled, or reused responsibly, according to the relevant laws and industrial standards. Robots or parts that can be reused or upcycled helps to reduce the usage of natural resources.

### Symbol

The following symbol indicates that the product must not be disposed of as common garbage. Handle each product according to local regulations for the respective content (see table below).

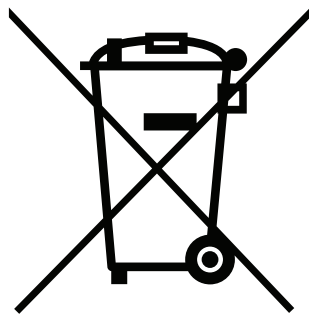

xx1800000058

### Materials used in the product

The table specifies some of the materials in the product and their respective use throughout the product.

Dispose components properly according to local regulations to prevent health or environmental hazards.

Material	Example application
Aluminium	Heat sinks on power supplies and drive units
Batteries, Lithium	Main computer
Brominated flame retardants	Electronics
Copper	Cables
Lead	Electronics
Plastic/rubber	Cables, connectors, etc.
Steel	Cabinet structure, plates, screws, etc.

*Continues on next page*

#### China RoHS symbol

The following symbol shows the information to hazardous substances and the environmental protection use period of OmniCore V250XT Type B according to "Management Methods for the Restriction of the Use of Hazardous Substances in Electrical and Electronic Products (SJ/T 11364-2014)".



xx190000804

Orange symbol with a number in it: The product contains certain hazardous substances and can be used safely during its environmental protection use period (as indicated by the number in the center) which should enter into the recycling system after its environmental protection use period.



#### Note

This form and environmental protection use period label are based on the regulation in China. These are not necessary to be concerned in other countries.

**This page is intentionally left blank**

---

# 7 Troubleshooting

## 7.1 Introduction to troubleshooting

---

### Introduction

The product manual and the circuit diagram contains information that can be good when troubleshooting.

For OmniCore, all event logs from the software can be seen on the FlexPendant, or in *Technical reference manual - Event logs for RobotWare 7*.

Make sure to read through the section [Safety on page 13](#) before starting.



#### Note

During troubleshooting with power on, the internal fan might cause dust to enter the cabinet.



#### CAUTION

During troubleshooting with power on, make sure not to place your head too close to the internal fan located on the door.

---

### Troubleshooting strategies

- 1 Isolate the fault to pinpoint the cause of the problem from consequential problems.
  - 2 Divide the fault chain in two.
  - 3 Check communication parameters and cables.
  - 4 Check that the software version is compatible with the hardware.
- 

### Work systematically

- 1 Take a look around to make sure that all screws, connectors, and cables are secured, and that the robot and other parts are clean, not damaged, and correctly fitted.
  - 2 Replace one thing at a time.
  - 3 Do not replace units randomly.
  - 4 Make sure that there are no loose screws, turnings, or other unexpected parts remaining after work has been performed.
  - 5 When the work is completed, verify that the safety functions are working as intended.
- 

### Keep a track of history

- Make a historical fault log to keep track of problems over time.
  - Consult those working with the robot when the problem occurred.
- 

*Continues on next page*

## 7 Troubleshooting

### 7.1 Introduction to troubleshooting

*Continued*

#### Basic scenarios

What to look for during troubleshooting depends on when the fault occurred. Was the robot recently installed or was it recently repaired? The following table gives hints on what to look for in specific situations.

The robot has recently been installed	<p>Check:</p> <ul style="list-style-type: none"> <li>• the configuration files</li> <li>• connectors</li> <li>• options and their configuration</li> <li>• changes in the robot working space/movements.</li> </ul>
The robot has recently been repaired	<p>Check:</p> <ul style="list-style-type: none"> <li>• all connections to the replaced part</li> <li>• power supplies</li> <li>• that the correct part has been fitted</li> <li>• the last repair documents.</li> </ul>
The robot recently had a software upgrade	<p>Check:</p> <ul style="list-style-type: none"> <li>• software versions</li> <li>• compatibilities between hardware and software</li> <li>• options and their configuration</li> </ul>
The robot has recently been moved from one site to another (an already working robot)	<p>Check:</p> <ul style="list-style-type: none"> <li>• connections</li> <li>• software versions</li> </ul>

#### Power supply distribution

The following block diagram illustrates the power supply distribution.

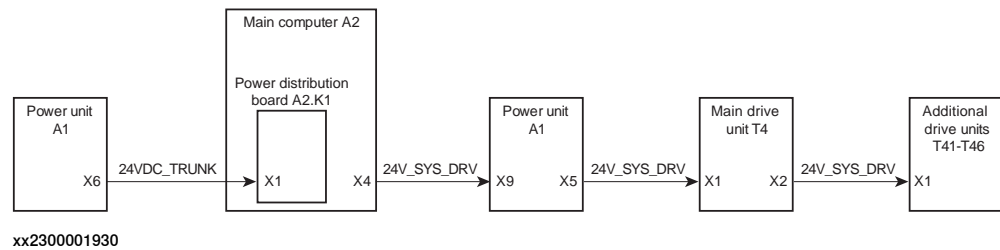

## 7.2 Troubleshooting fault symptoms

---

### Fault symptoms described in this manual

This manual describes how to troubleshoot the following fault symptoms:

- [No LEDs are lit on the controller on page 356](#)
- [Start-up failure on page 359](#)
- [Problem releasing the robot brakes on page 363](#)
- [Problem starting or connecting the FlexPendant on page 366](#)
- [Problem using the joystick on page 370](#)
- [Controller fails to start on page 371](#)
- [Reflashing firmware failure on page 372](#)
- [Inconsistent path accuracy on page 373](#)
- [Controller is overheated on page 375](#)

*Continues on next page*

## 7 Troubleshooting

---

### 7.2.1 No LEDs are lit on the controller

### 7.2.1 No LEDs are lit on the controller

---

#### Description

No LEDs at all are lit in the controller.

---

#### Required test equipment

Equipment needed for troubleshooting:

Equipment	Note
Multimeter	
Insulating gloves	

---

#### Preparations

	Action
1	Make sure that the controller is switched on. Wait 30 s - 1 min to enable start-up sequence.
2	Check the FlexPendant for errors and warnings.
	 <b>DANGER</b> Troubleshooting on the controller while powered on must be performed by personnel trained by ABB or by ABB field engineers.

---

#### Recommended working procedure

If no LEDs are lit on the controller during start-up, use this procedure to troubleshoot what might cause the problem.

*Continues on next page*



Look at the following block diagram to understand how power is connected from incoming and forward.

Troubleshooting flowchart

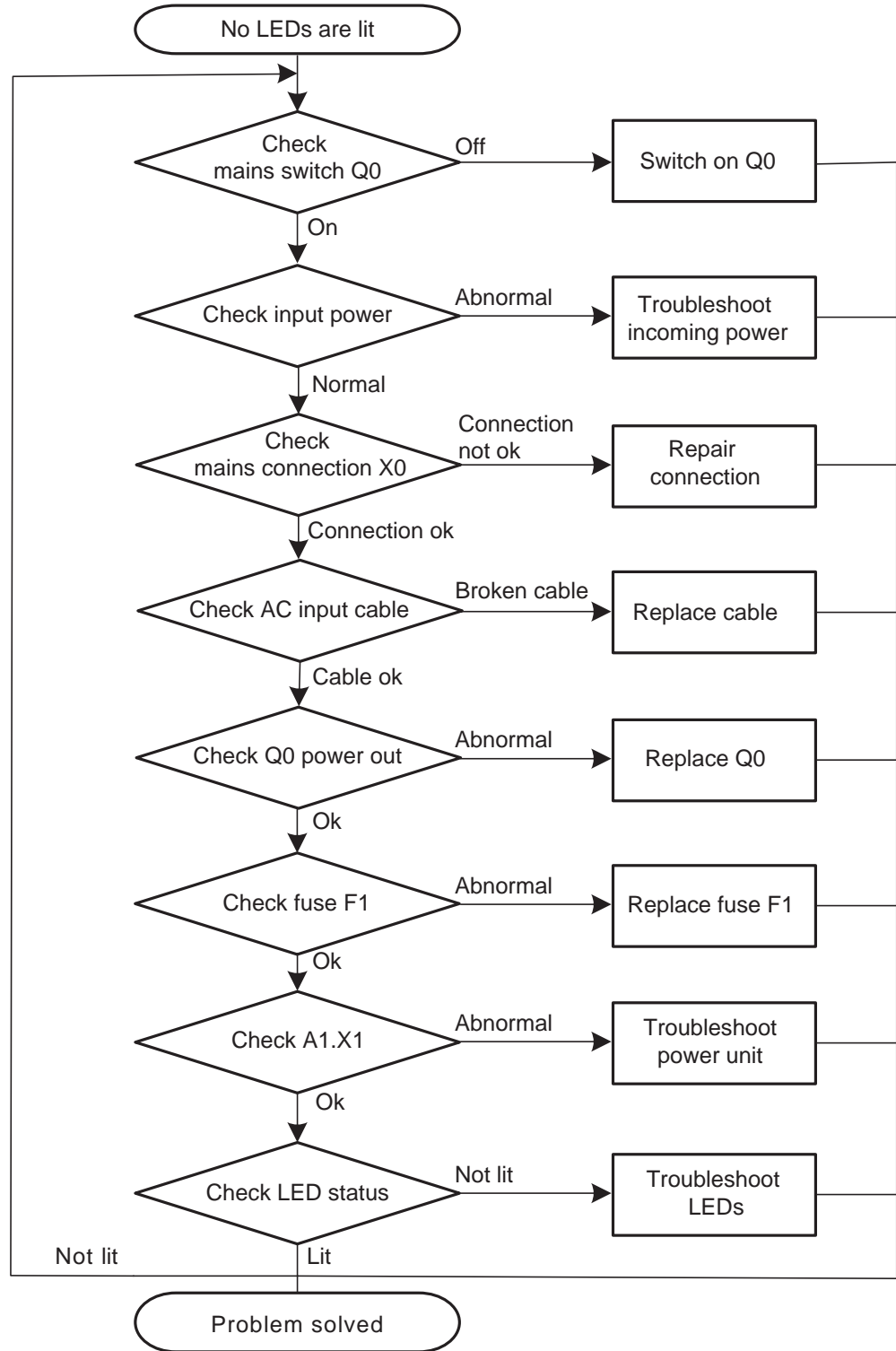

xx2100001064

Continues on next page

## 7 Troubleshooting

### 7.2.1 No LEDs are lit on the controller

*Continued*

#### Detailed working procedure

	Action	Note
1	Make sure that the mains switch (Q0) has been switched on.	
2	Make sure that the system is supplied with power. <ul style="list-style-type: none"><li>• Measure incoming mains voltage and make sure the voltage is within the normal range.</li></ul>	Use a multimeter and insulating gloves. If incoming mains is not ok, the problem is not in the robot controller. Troubleshoot incoming mains.
3	Check that the mains connection (X0) is properly connected.   <b>Tip</b>  For more details, see <i>Circuit diagram - OmniCore V250XT</i> , rev 04 or later.	
4	Check that the AC input cable is properly connected.	
5	Check the output voltage of (Q0). <ul style="list-style-type: none"><li>• Make sure that (Q0) is closed.</li></ul>	Use a multimeter and insulating gloves.
6	Check the fuse (F1).	Replace if damaged.
7	Check connector A1.X1.	<ul style="list-style-type: none"><li>• If abnormal, troubleshoot the power unit. See <a href="#">Troubleshooting the power unit on page 391</a>.</li></ul>
8	Check the LED status.	<ul style="list-style-type: none"><li>• If abnormal, troubleshoot the LEDs. See <a href="#">Troubleshooting LEDs in the controller on page 376</a>.</li></ul>

## 7.2.2 Start-up failure

### Description

The following are possible symptoms of a start-up failure:

- 1 The LEDs are not lit on some units.
- 2 Unable to load the system software.

### Required test equipment

Equipment needed for troubleshooting:

Equipment	Note
Multimeter	
Insulating gloves	
<i>Circuit diagram - OmniCore V250XT, rev 04 or later</i>	<i>3HAC074000-008</i>

### Preparations

	Action
1	Make sure that the controller is switched on. Wait 30 s - 1 min to enable start-up sequence.
2	Check the FlexPendant for errors and warnings.
	 <b>DANGER</b> Troubleshooting on the controller while powered on must be performed by personnel trained by ABB or by ABB field engineers.

*Continues on next page*

## 7 Troubleshooting

### 7.2.2 Start-up failure

Continued

#### Recommended working procedure

If there seems to be a power failure during start-up, use this procedure to troubleshoot what might cause the problem.

#### Block diagram

Look at the following block diagram to understand how power is connected from incoming and forward.

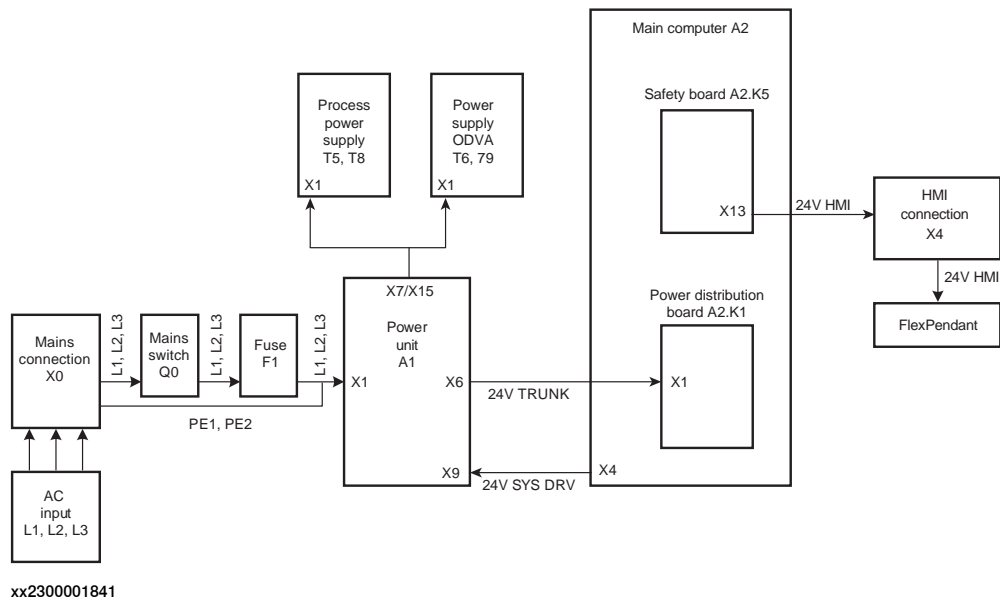

#### Detailed working procedure

	Action	Note
1	Check <b>Module status LED</b> on power unit A1.	<p><b>LED Module status</b> should be green.</p> <ul style="list-style-type: none"> <li>If not, see <a href="#">Troubleshooting the power unit on page 391</a>.</li> <li>If the power unit is ok, check that incoming mains is well connected and that the incoming mains switch is turned on.</li> </ul>
2	Check <b>LED TRK</b> on the main computer (Power distribution board, DSQC1085).	<ul style="list-style-type: none"> <li>If LED TRK is green, proceed with <a href="#">5</a>.</li> <li>If LED TRK is not green, proceed with <a href="#">3</a>.</li> </ul>
3	Measure the 24VDC_TRUNK at connector A2.K1.X1.	<p>Verify that the input to A2.K1.X1 is 25.2 VDC +/- 5%.</p> <ul style="list-style-type: none"> <li>If the measured voltage is normal, troubleshoot the main computer. See <a href="#">Troubleshooting the main computer on page 424</a>.</li> <li>If the measured voltage is abnormal, proceed with step <a href="#">4</a>.</li> </ul>

Continues on next page

	Action	Note
4	Measure the 24VDC_TRUNK at connector A1.X6.	<p>Verify that the input to A1.X6 is 25.2 VDC +/- 5%.</p> <ul style="list-style-type: none"> <li>• If the measured voltage is normal, check and replace the cable if necessary.</li> <li>• If the measured voltage is abnormal, troubleshoot the power unit. See <a href="#">Troubleshooting the power unit on page 391</a>.</li> </ul>
5	Check LEDs PC (Power distribution board, DSQC1085) and HMI (Safety board, DSQC1087).	<ul style="list-style-type: none"> <li>• LED PC and/or LED HMI are green, proceed with <a href="#">6</a>.</li> <li>• LED PC and/or LED HMI are not green,, troubleshoot the main computer. See <a href="#">Troubleshooting the main computer on page 424</a>.</li> </ul>
6	Check the drive unit status LED.	If the drive unit status LED is not lit, see <a href="#">Troubleshooting the drive unit on page 378</a> .
7	If the problem remains, contact ABB.	



**Tip**

For more details, see *Circuit diagram - OmniCore V250XT*, rev 04 or later.

## 7 Troubleshooting

---

### 7.2.3 System update failure

### 7.2.3 System update failure

---

#### Description

In certain scenarios, such as removing or adding certain optional features or major upgrades of installed software products versions, the previous backup may be incompatible with the newly re-configured system. Automatically reloading backup can therefore fail, resulting in system failure state after the update.

For more information about system update, see *Operating manual - Integrator's guide OmniCore*.

---

#### Recommended working procedure

To remove system failure resulting from system updates, there are two main strategies:

- A Go forward with the new system configuration and correct the errors, see [New system configuration on page 362](#).
- B Rollback all changes in the system and bring the system to the same state as it was before the update, see [Rollback all changes in the system on page 362](#).

#### New system configuration

- 1 Reset the RobotWare system.  
The RAPID program and system parameters will be removed, and the system will be set to default state, but without system failure.
- 2 Re-implement your programs or configuration changes, or
- 3 Selectively load contents from the previous system backup and correct possible errors when loading.

#### Rollback all changes in the system

The previous system state can be restored through the RobotWare Installation Utilities in one of the following ways:

- 1 Restore all installed software, user and system internal data with a selected snapshot (backup copy) of the previous system state. This is the simplest way.
- 2 Perform a complete re-installation of the RobotWare system using RobotWare Installation Utilities, start the RobotWare system and then reload the previous backup.

## 7.2.4 Problem releasing the robot brakes

### Description

When starting robot operation or jogging the robot, the internal robot brakes must release in order to allow movement.

### Required test equipment

Equipment needed for troubleshooting:

Equipment	Note
Multimeter	
Insulating gloves	
Circuit diagram - OmniCore V250XT, rev 04 or later	3HAC074000-008

### Preparations

	Action
1	Make sure that the controller is switched on. Wait 30 s - 1 min to enable start-up sequence.
2	Check the FlexPendant for errors and warnings.
	 <b>DANGER</b> Troubleshooting on the controller while powered on must be performed by personnel trained by ABB or by ABB field engineers.

### Recommended working procedure

If the brakes do not release, no robot movement is possible and a number of error log messages can occur. Use this procedure to troubleshoot what might cause the problem.

Look at the following block diagram to understand how power is connected from incoming and forward.

### Block diagram

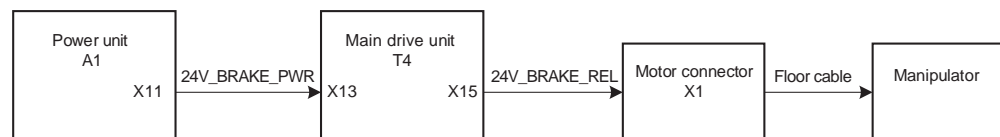

xx2100001141

Continues on next page

## 7 Troubleshooting

### 7.2.4 Problem releasing the robot brakes

Continued

#### Troubleshooting flowchart

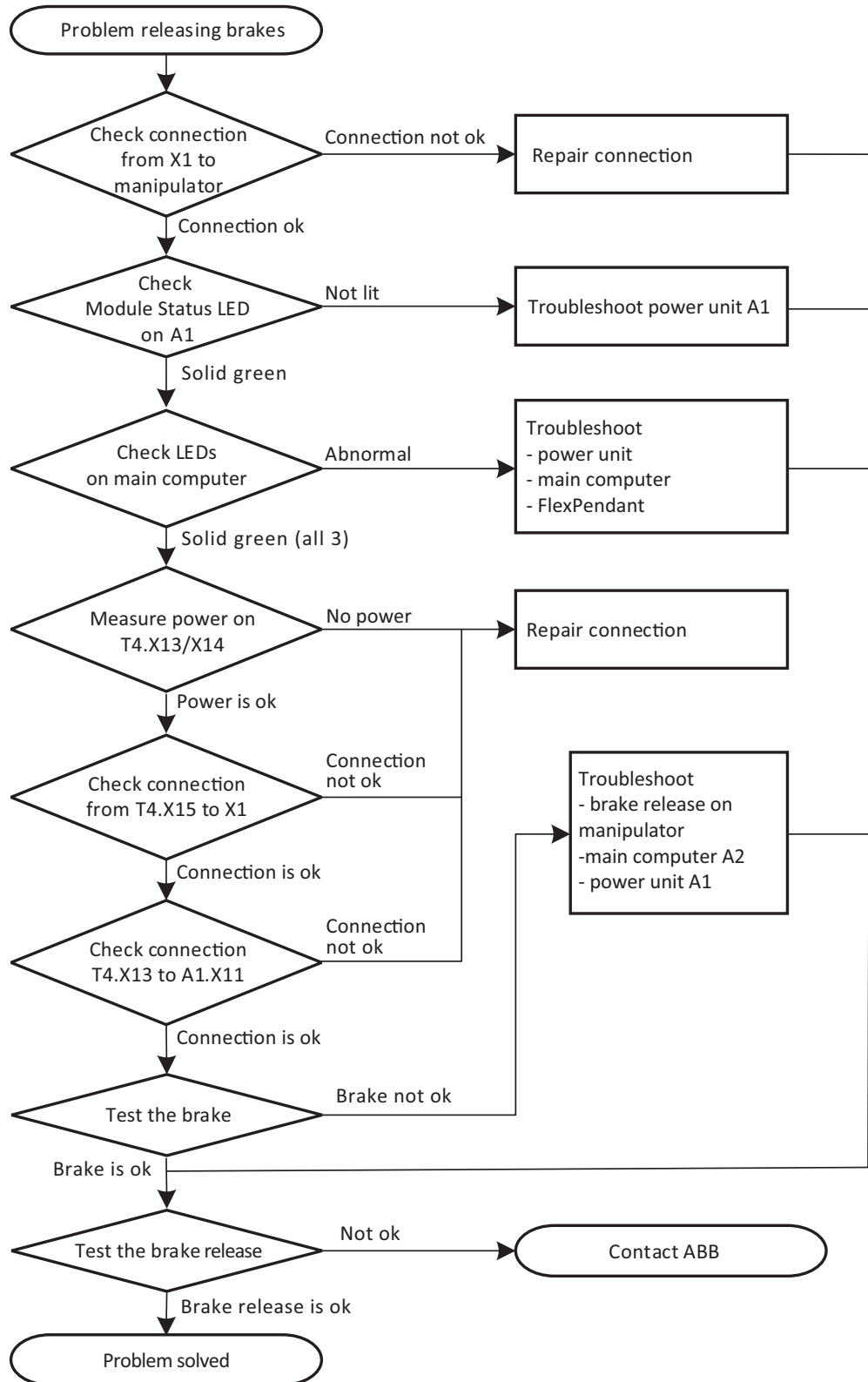



xx2300001758

Continues on next page



## Detailed working procedure

	Action	Note
1	<p>Check that the floor cable is connected from the manipulator to the motor connector X1. Visually inspect the cable for damage or extensive bending marks.</p> <p> <b>Tip</b></p> <p>For more details, see <i>Circuit diagram - OmniCore V250XT</i>, rev 04 or later.</p>	<ul style="list-style-type: none"> <li>• If the cable is damaged, replace to a new cable and go to step 8.</li> <li>• If the cable is not connected, repair the connection and go to step 8.</li> <li>• If the cable is ok, go to the next step.</li> </ul>
2	<p>Check the LED Module Status on the power unit A1. The LED should be solid green.</p>	<p>If it is not green, see <a href="#">Troubleshooting the power unit on page 391</a>.</p>
3	<p>Check the LEDs on the main computer, power distribution board DSQC1085. All LEDs should be solid green.</p>	
4	<p>Measure the power on T4.X13/X14.</p> <p> <b>Tip</b></p> <p>For more details, see <i>Circuit diagram - OmniCore V250XT</i>, rev 04 or later.</p>	<p>Use a multimeter and insulating gloves.</p> <ul style="list-style-type: none"> <li>• If there is no power, repair the connection and go to step 8.</li> <li>• If it is ok, go to the next step.</li> </ul>
5	<p>Check that the connection from the main drive unit to the motor connector is ok:</p> <ul style="list-style-type: none"> <li>• T4.X15 - X1.</li> </ul>	<ul style="list-style-type: none"> <li>• If it is not, repair the connection and go to step 8.</li> <li>• If it is ok, go to the next step.</li> </ul>
6	<p>Check that the connection from the main drive unit to the power unit is ok:</p> <ul style="list-style-type: none"> <li>• T4.X13 - A1.X11</li> </ul>	<ul style="list-style-type: none"> <li>• If it is not, repair the connection and go to step 8.</li> <li>• If it is ok, go to the next step.</li> </ul>
7	<p>Try jogging the robot.</p>	<ul style="list-style-type: none"> <li>• If it is not working properly, the brake release board on the manipulator might be broken. Contact your local ABB for more information.</li> <li>• If the brakes work normally, troubleshoot the main computer, the robot signal exchange proxy, and the power unit, one by one. If needed, replace faulty units. Go to step 8.</li> </ul>
8	<p>Check that the brake release function is ok.</p>	<p>For more details on how to release the brakes, see the robot's product manual.</p> <ul style="list-style-type: none"> <li>• If it is not ok, contact your local ABB.</li> </ul>

## 7 Troubleshooting

### 7.2.5 Problem starting or connecting the FlexPendant

### 7.2.5 Problem starting or connecting the FlexPendant

#### Description

The FlexPendant is not responding, either completely or intermittently. No entries are possible, and no functions are available.



#### Note

If protective gloves are used, these must be compatible with touchscreens when using the FlexPendant.

The FlexPendant starts but does not display the main interface.

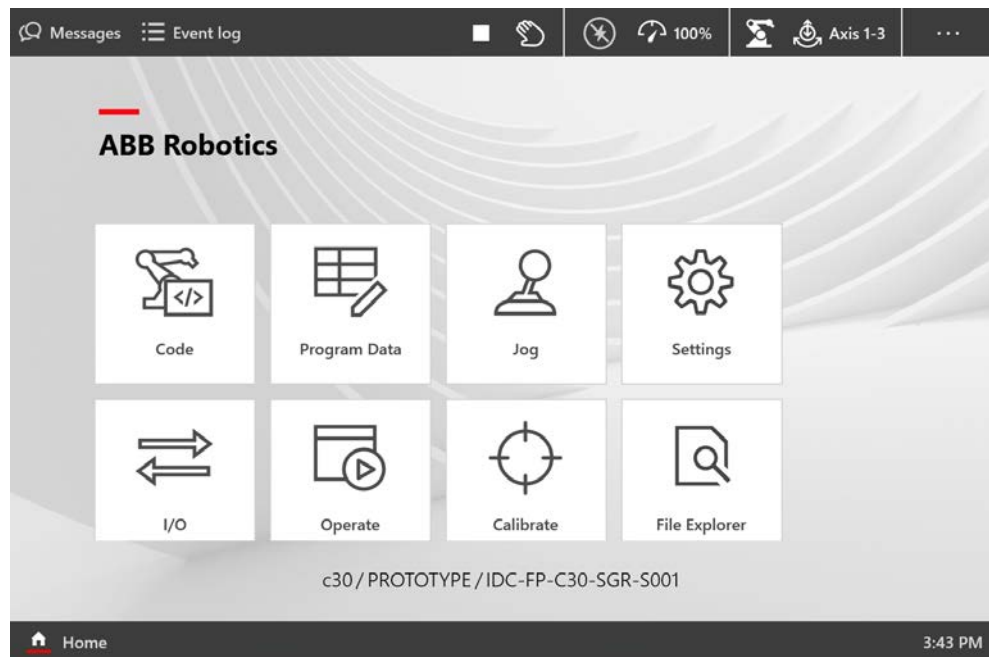

xx1900000917

#### Required test equipment

Equipment needed for troubleshooting:

Equipment	Note
Multimeter	
Insulating gloves	
Circuit diagram - OmniCore V250XT, rev 04 or later	3HAC074000-008

#### Preparations

	Action
1	Make sure that the controller is switched on. Wait 30 s - 1 min to enable start-up sequence.
2	Check the FlexPendant for errors and warnings.

Continues on next page

	Action
	 <b>DANGER</b> Troubleshooting on the controller while powered on must be performed by personnel trained by ABB or by ABB field engineers.

#### Recommended working procedure

If the FlexPendant starts but does not display the main interface during the start-up, use this procedure to troubleshoot what might cause the problem.

## 7 Troubleshooting

### 7.2.5 Problem starting or connecting the FlexPendant

*Continued*

Look at the following block diagram to understand how power is connected from incoming and forward.

#### Troubleshooting flowchart

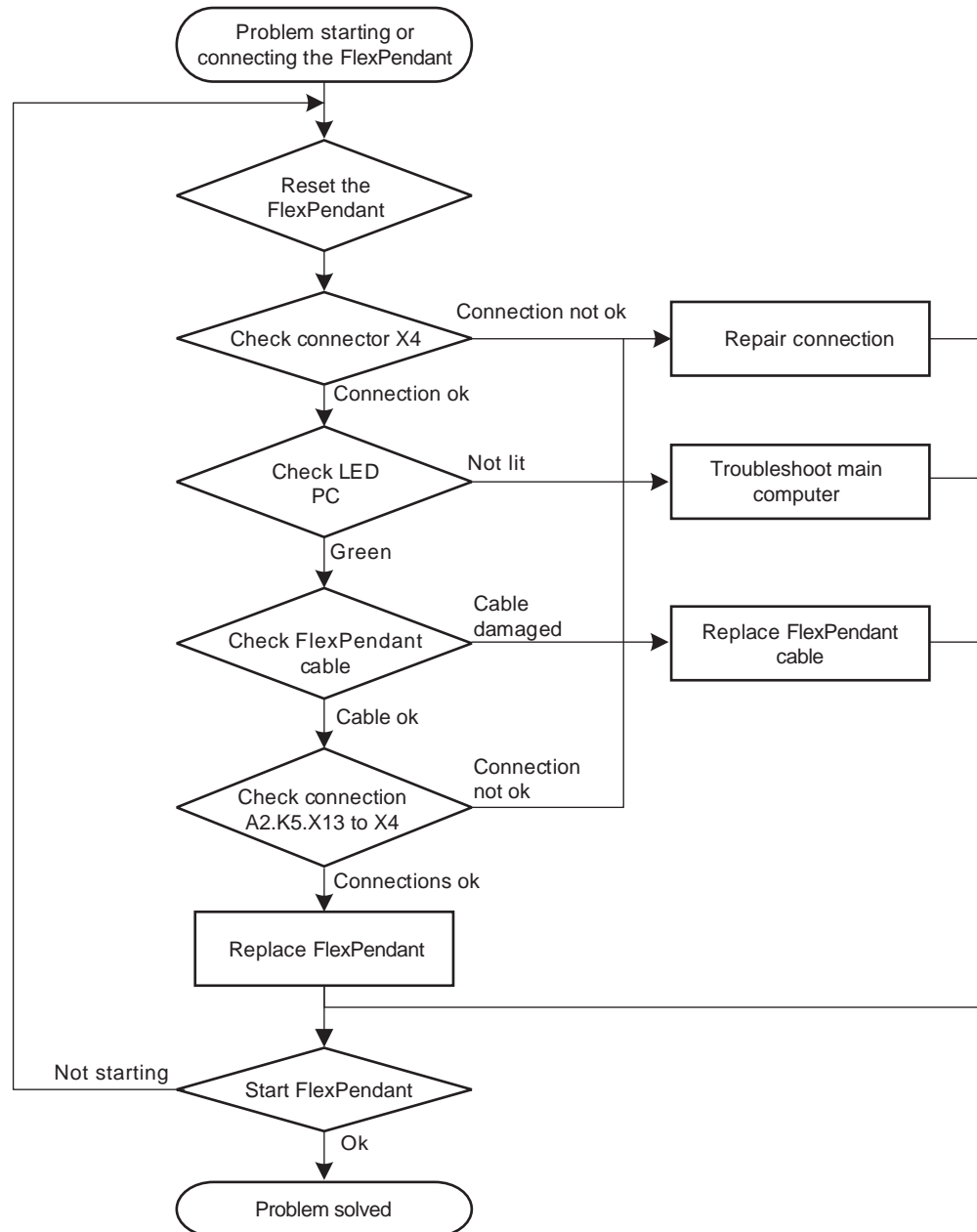

xx2300001760

#### Location of LEDs

Information about LEDs not yet available.

#### Detailed working procedure

	Action	Note
1	Try resetting the FlexPendant using the reset button located next to the USB port.	See <i>Operating manual - OmniCore</i> .

*Continues on next page*

	Action	Note
2	Check that the FlexPendant cable is correctly connected to the controller through the HMI signal connector, X4.	If it is not connected, repair the connection and go to step six. Check the pins in the connector. If it is ok, go to the next step.
3	Check the FlexPendant cable for any damage.	<ul style="list-style-type: none"> <li>• If damage is found, replace the FlexPendant cable and go to step six.</li> <li>• If it is ok, go to the next step.</li> </ul>
4	If possible, test by connecting another FlexPendant. This is to eliminate the FlexPendant and cable as error sources; Test the FlexPendant with a different controller to eliminate the controller as error source.	
5	Check that the FlexPendant works normally.   <b>Tip</b>  This is detailed in section <a href="#">Troubleshooting the FlexPendant on page 377</a> .	If it is not ok, contact your local ABB.

## 7 Troubleshooting

---

### 7.2.6 Problem using the joystick

### 7.2.6 Problem using the joystick

---

#### Description

The FlexPendant is started and responds when you push the buttons or tap on the touchscreen. However, the joystick does not work and no warnings or messages show up. It is therefore not possible to jog the robot.

---

#### Recommended working procedure

	Action	Information
1	Make sure that the joystick lock is not activated.	See <i>Operating manual - OmniCore</i> .
2	Make sure the controller is in manual mode.	
3	Make sure the FlexPendant is connected correctly to the controller.	
4	Press the reset button located next to the USB port on the back of the FlexPendant.   <b>Note</b> The reset button only resets the FlexPendant, not the system on the controller.	If the joystick is still not working, then replace the FlexPendant.

---

## 7.2.7 Controller fails to start

---

### Description

If the controller fails to start, the FlexPendant is not operational.

---

### Function description

The robot controller always runs in one of the following two modes:

- Normal operation mode (a user-created system is selected to run)
- RobotWare Installation Utilities mode (advanced maintenance mode)

In rare occasions, a serious error (in the software or the configuration of the installed system), may prevent the controller from starting properly in the normal operation mode. A typical case is when a controller is restarted after a network configuration change, causing the controller to be non-responsive from FlexPendant, RobotStudio, or FTP. To restore the robot controller from this situation, the controller can be forced to start in RobotWare Installation Utilities mode.

---

### Forcing startup of the RobotWare Installation Utilities mode

Repeat the following action two times in a row:

- 1 Turn on the main power switch.
- 2 Wait for approximately 15 seconds.
- 3 Turn off the main power switch.

In the next startup (third time), the installed system is de-selected and the RobotWare Installation Utilities mode is started.

This has no effect if the controller is already in RobotWare Installation Utilities mode.



#### Note

Force starting the RobotWare Installation Utilities mode will not affect the files in the directories belonging to the installed system.

How to install systems is described in *Operating manual - Integrator's guide OmniCore*.

## 7 Troubleshooting

---

### 7.2.8 Reflashing firmware failure

### 7.2.8 Reflashing firmware failure

---

#### Description

When reflashing firmware, the automatic process can fail which will stop the system. A message is generated in the event log.

This fault usually occurs due to a lack of compatibility between hardware and software.

---

#### Recommended working procedure

If the controller stops with a message about firmware failure, use this procedure to troubleshoot what might cause the problem.

	Action	Note
1	Read the message to see which unit has failed.	
2	If the relevant unit has been replaced recently, make sure that the versions of the old and the new unit are identical.	
3	Check the software versions.	
4	If RobotWare has been updated recently, make sure that the versions of the old and the new unit are identical.	
5	If the problem remains, contact your local ABB for information about which firmware version is compatible with your hardware.	



## 7.2.9 Inconsistent path accuracy

### Description

The path of the robot TCP is not consistent. It varies from time to time, and is sometimes accompanied by noise emerging from bearings, gearboxes, or other locations.

### Possible causes

The symptom can be caused by (the causes are listed in order of probability):

- Robot not calibrated correctly.
- Robot TCP not correctly defined.
- Parallel bar damaged (applies to robots fitted with parallel bars only).
- Mechanical joint between motor and gearbox damaged. This often causes noise to be emitted from the faulty motor.
- Bearings damaged or worn (especially if the path inconsistency is coupled with clicking or grinding noises from one or more bearings).
- The wrong robot type may be connected to the controller.
- The brakes may not be releasing correctly.

### Recommended working procedure

The path accuracy depends on many factors. The following table describes the most common causes of problems with the path accuracy. Depending on your installation, the recommended working procedure is to work step by step, starting with the step that seems most plausible given your circumstances.

	Action	Note
1	Study the path of the robot in motion, to find if an external force, for example, an external cable package, is colliding with or restricting the movement of the robot.	Remove the obstacles.
2	In high temperature environments, the material in the robot can expand, thereby causing inconsistent path accuracy.	Improve the ventilation around the robot.
3	Make sure the robot tool and work object are correctly defined.	How to define these are described in <i>Operating manual - OmniCore</i> .
4	Check the positions of the revolution counters.	Update if required.
5	If required, re-calibrate the robot axes.	How to calibrate the robot is described in the product manual for the robot.
6	If you hear noise that has not been there before, locate the source to define if a motor or bearing is faulty.  Study the path of the robot TCP to establish which axis, and thus which motor, may be faulty.	Replace the faulty motor, gearbox, or bearing as specified in the product manual for the robot.
7	Check the trueness of the parallel bar (applies to robots fitted with parallel bars only).	Replace the faulty parallel bar as specified in the product manual for the robot.

*Continues on next page*

## 7 Troubleshooting

---

### 7.2.9 Inconsistent path accuracy

*Continued*

	Action	Note
8	Make sure the correct robot type is connected as specified in the system.	Update the system with the correct robot type, see <i>Operating manual - Integrator's guide OmniCore</i> .
9	Make sure the robot brakes work properly.	Proceed as detailed in section <a href="#">Problem releasing the robot brakes on page 363</a> .
10	If applicable: Check the setting for the swivel.	The swivel has an in-built resistance that needs to be set in the system parameters.

## 7.2.10 Controller is overheated

### Required test equipment

Equipment needed for troubleshooting:

Equipment	Note
Multimeter	
Insulating gloves	
Circuit diagram - OmniCore V250XT, rev 04 or later	3HAC074000-008

### Preparations

	Action
1	Make sure that the controller is switched on. Wait 30 s - 1 min to enable start-up sequence.
2	Check the FlexPendant for errors and warnings.
	 <b>DANGER</b> Troubleshooting on the controller while powered on must be performed by personnel trained by ABB or by ABB field engineers.

### Recommended working procedure

If the controller seems to be overheated, use this procedure to troubleshoot what might cause the problem.

### Detailed working procedure

	Action	Note
1	Check that the external fans are working.	Replace malfunctioning fans, see <a href="#">Replacing the external fans on page 194</a> .
2	Check that the internal fan is working.	Replace malfunctioning fans, see <a href="#">Replacing the internal fan on page 198</a> .
3	Check that the power unit fan is working.	Replace malfunctioning fans, see <a href="#">Replacing the power unit fan on page 206</a> .
4	Inspect the air filters to make sure they are clean.	If air filters are not clean, see <a href="#">Cleaning air filter on page 167</a> If air filters need to be replaced, see <a href="#">Replacing the air filter on page 285</a> .
5	If the problem remains, troubleshoot the power unit and/or the drive unit.	See <a href="#">Troubleshooting the power unit on page 391</a> and <a href="#">Troubleshooting the drive unit on page 378</a> .

## 7 Troubleshooting

---

### 7.3.1 Troubleshooting LEDs in the controller

## 7.3 Troubleshooting units

### 7.3.1 Troubleshooting LEDs in the controller

---

#### Description

The controller features a number of indication LEDs, which provide important information for troubleshooting purposes. If no LEDs light up at all when switching the system on, troubleshoot as detailed in this section.

All LEDs on the respective units, and their significance, are described in the following sections.

#### Units with LEDs in the controller

---

Drive unit	<a href="#">Troubleshooting the drive unit on page 378</a>
Additional drive unit	<a href="#">Troubleshooting the additional drive unit on page 384</a>
Power unit	<a href="#">Troubleshooting the power unit on page 391</a>
Scalable I/O	<a href="#">Troubleshooting fieldbuses and I/O on page 404</a>
3G Connected Services gateway	<a href="#">Troubleshooting the 3G Connected Services gateway on page 405</a>
4G Connected Services gateway	<a href="#">Troubleshooting the 4G Connected Services gateway on page 411</a>
Ethernet switch	<a href="#">Troubleshooting the Ethernet switch (DSQC1035) on page 422</a>
Main computer	<a href="#">Troubleshooting the main computer on page 424</a>
Power supply	<a href="#">Troubleshooting the power supply, ODVA on page 431</a> and <a href="#">Troubleshooting the process power supply on page 430</a>

## 7.3.2 Troubleshooting the FlexPendant

### Procedure

The procedure below describes what to do if the FlexPendant does not work correctly.

	Action	Note
1	Try resetting the FlexPendant using the reset button located next to the USB port.	See <i>Operating manual - OmniCore</i> .
2	If the FlexPendant is not responding or does not operate correctly, see <a href="#">Problem starting or connecting the FlexPendant on page 366</a> .	 <b>Note</b> If protective gloves are used, these must be compatible with touchscreens when using the FlexPendant.
3	Check the cable for connections and integrity.	
4	Check the 24 V power supply.	
5	Read the error event log message and follow any instructions of references.	

For more information on the FlexPendant, see *Operating manual - OmniCore*.

## 7 Troubleshooting

### 7.3.3 Troubleshooting the drive unit

### 7.3.3 Troubleshooting the drive unit

#### Location

The illustration shows the location of the drive unit in the controller.

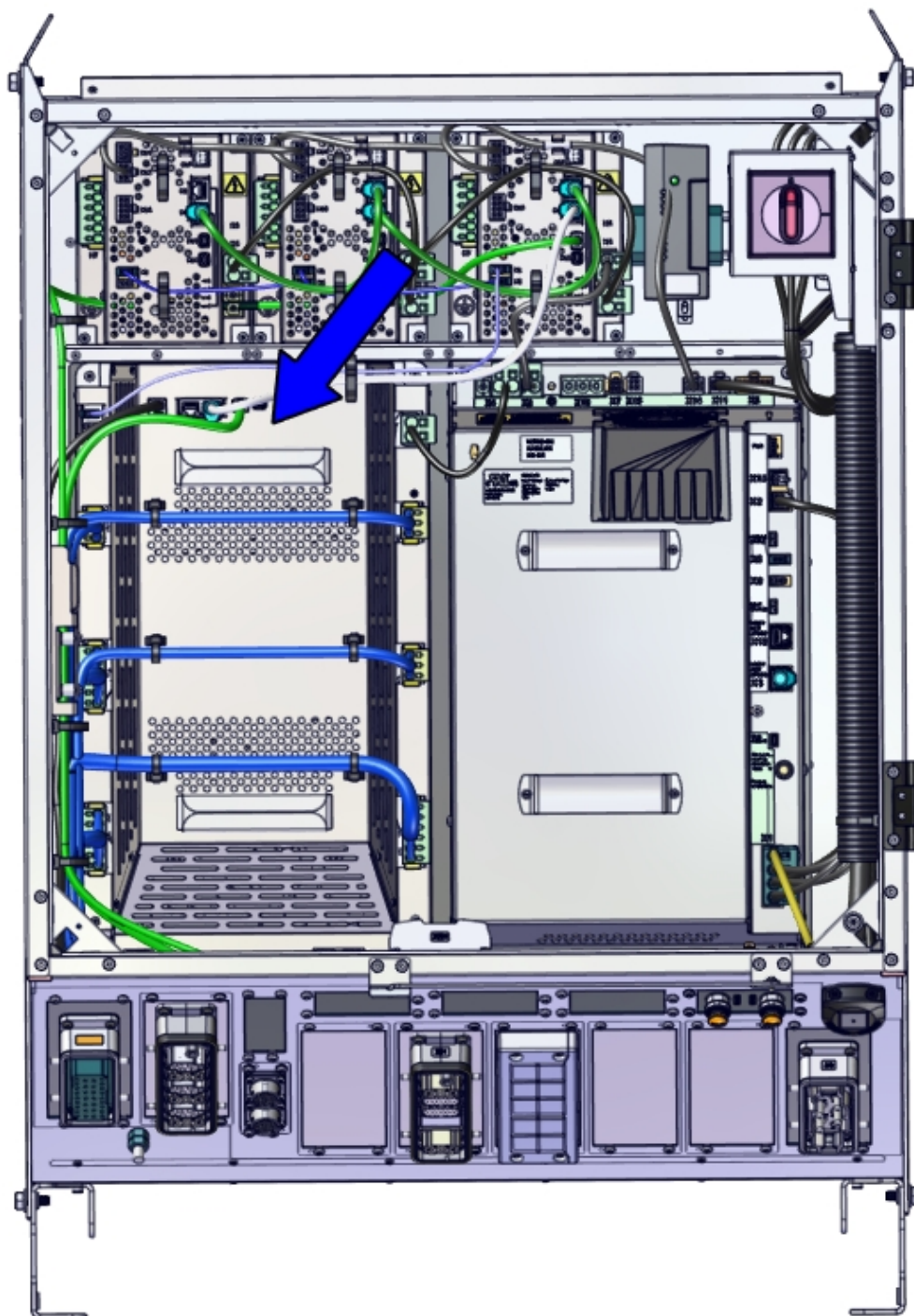

xx2300001839

*Continues on next page*

#### LEDs

The illustration below shows the indication LEDs on the drive unit.

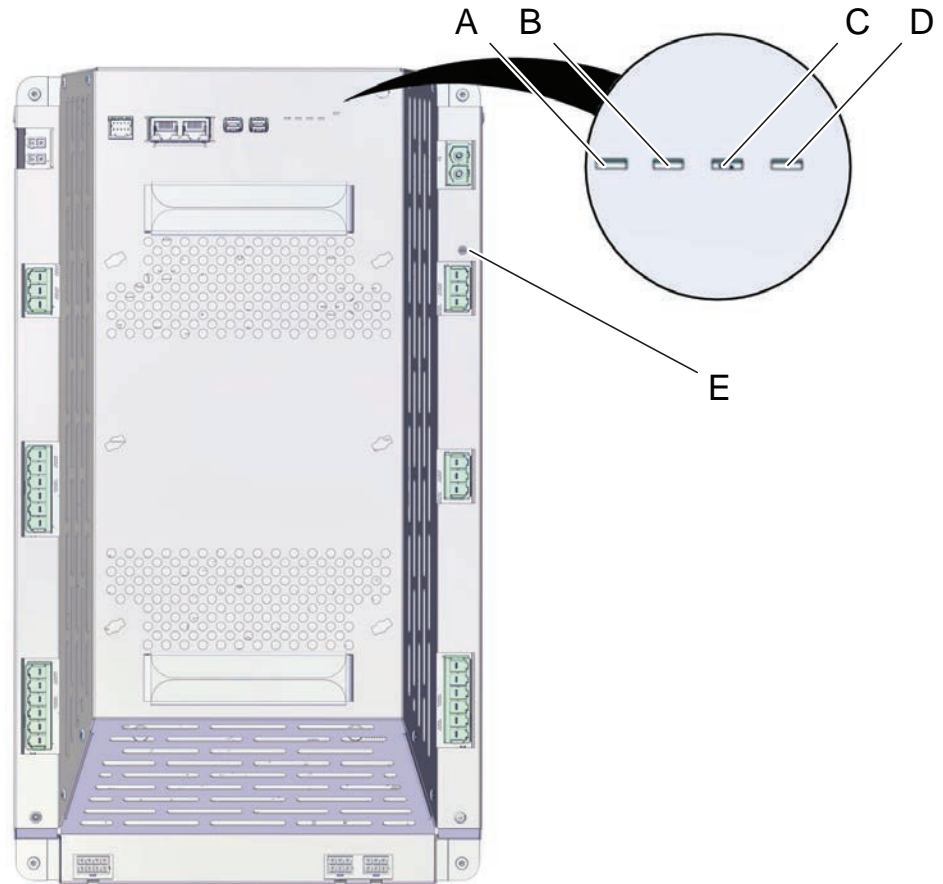

xx2100001069

	Name	Description
A	MS (Module Status) LED	<p>The status indicator LED can be used to identify the following status during start-up/power on:</p> <ul style="list-style-type: none"> <li>• Red, steady: Default when power is available.</li> <li>• Red, flashing (~1Hz): Power is on, self-test is ongoing, operating system is loading.</li> <li>• Green, flashing (~1Hz): Application is loaded and waiting for communication.</li> <li>• Green, steady: Drive unit is operational.</li> </ul> <p>If the LED does not turn steady green after 30-60 sec, the status indicator LED can be used to identify the following issues:</p> <ul style="list-style-type: none"> <li>• No color: Power to the drive unit is missing.</li> <li>• Red, steady: Internal error.</li> <li>• Red, flashing (~1Hz): Firmware error or self-test failure.</li> <li>• Green, flashing (~1Hz): Communication error to another module.</li> </ul>

*Continues on next page*

## 7 Troubleshooting

### 7.3.3 Troubleshooting the drive unit

Continued

	Name	Description
B	LA (Link Activity [0]) LED	Shows the Link activity of the EtherCAT slave port 0. <ul style="list-style-type: none"> <li>• Off: No link</li> <li>• Yellow flashing: Link and activity.</li> <li>• Yellow steady: Link without activity.</li> </ul>
C	RUN (EtherCAT RUN) LED	Shows the actual state of the device state machine: <ul style="list-style-type: none"> <li>• Off: Drive unit is in state INIT.</li> <li>• Green flashing (slow): Drive unit is in state PRE-OPERATIONAL.</li> <li>• Green single flash: Drive unit is in state SAFE-OPERATIONAL.</li> <li>• Green steady: Drive unit is in state OPERATIONAL.</li> <li>• Green flickering (fast): Drive unit is in state BOOTSTRAP.</li> </ul>
D	LA (Link Activity [1]) LED	Shows the Link activity of the EtherCAT slave port 1. <ul style="list-style-type: none"> <li>• Off: No link</li> <li>• Yellow flashing: Link and activity.</li> <li>• Yellow steady: Link without activity.</li> </ul>
E	DC-BUS High Voltage LED	<ul style="list-style-type: none"> <li>• No color: Voltage between DC+ - DC- &lt; 60 VDC</li> <li>• Yellow: Voltage between DC+ - DC- &gt; 60 VDC</li> </ul>

#### Required test equipment

Equipment needed for troubleshooting:

Equipment	Note
Multimeter	
Insulating gloves	
Circuit diagram - OmniCore V250XT, rev 04 or later	3HAC074000-008

#### Preparations

	Action
1	Check the FlexPendant for errors and warnings.
2	Power the controller off. Wait one minute, power the controller on.
3	Wait 30-60 seconds after power-on. Make sure that the control system power is in run-time mode.

Continues on next page



Troubleshooting flowchart

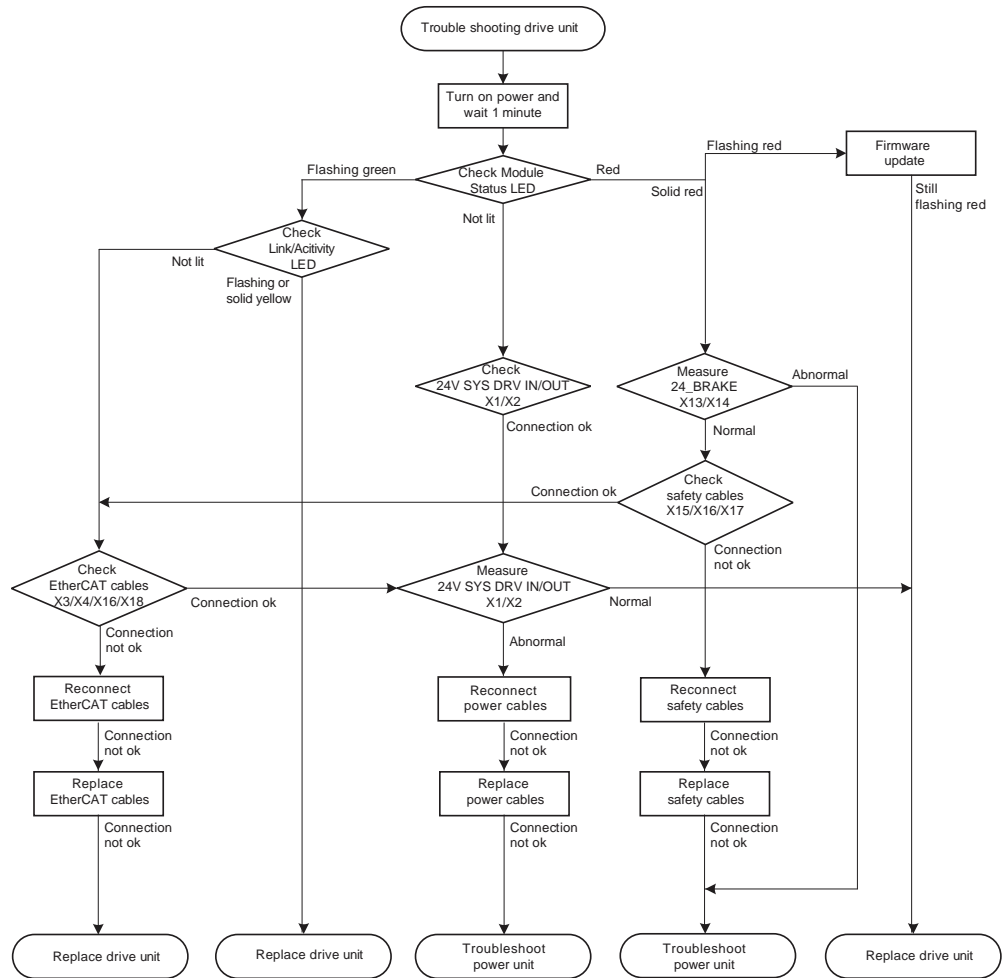

xx2100001982

Troubleshooting procedure

The troubleshooting table is supposed to be used as a detailed instruction together with the troubleshooting flowchart.

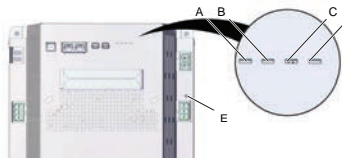
	Action	Note
1	<p>Power on the controller. Check the Module Status LED (A) on the drive unit.</p>  <p>xx2100002221</p>	<p>Make sure that the drive unit is operational. Wait at least 1 min after power-on.</p> <p>If the Module Status LED is:</p> <ul style="list-style-type: none"> <li>• Off: The drive unit is in the power off state. Proceed with step 4.</li> <li>• Red, steady: Internal error. Proceed with step 2.</li> <li>• Flashing red (~ 1Hz): Firmware error or self-test failure. Upgrade the firmware. If the problem persists, the drive unit may be faulty, see <a href="#">Replacing the drive unit on page 267</a>.</li> <li>• Flashing green (~ 1Hz): Communication error to another module. Proceed with step 3.</li> </ul>

Continues on next page

## 7 Troubleshooting

### 7.3.3 Troubleshooting the drive unit

Continued

	Action	Note
2	Measure the 24_BRAKE input at connector X13/X14.	Verify that the input to X13/X14 is 24 VDC $\pm$ 10%. <ul style="list-style-type: none"> <li>If the measured voltage is normal, proceed with step 10.</li> <li>If the measured voltage is abnormal, there is an issue with the 24 VDC supply from the power unit. See <a href="#">Troubleshooting the power unit on page 391</a>.</li> </ul>
3	Check the two Link/Activity LEDs (B & D). These LEDs indicate the communication status of the module.	Make sure that the drive unit is operational. If the Link/Activity LED is: <ul style="list-style-type: none"> <li>Yellow, steady: The communication link is established. The drive unit may be faulty, see <a href="#">Replacing the drive unit on page 267</a>.</li> <li>Flashing yellow: The communication link is established and data is transferred through the port. The drive unit may be faulty, see <a href="#">Replacing the drive unit on page 267</a>.</li> <li>Off: The EtherCAT link is not established. Proceed with step 5.</li> </ul>
4	Check the connectors at T4.X1 (24V SYS DRV IN) and T4.X2 (24V SYS DRV OUT). Make sure that the power cables are connected properly at both ends.	If the connection and cable seem OK, proceed with step 6. If there is a problem with the connection, proceed with step 7.
5	Check the cables X3/X4/X16/X18. Make sure that the cables are connected properly at both ends.	If the connection seems OK, proceed with step 6. If there is a problem with the connection, proceed with step 7.
6	Measure the 24VDC SYS DRV input at connector X1/X2.	Verify that the input to X1/X2 is 24 VDC $\pm$ 10%. <ul style="list-style-type: none"> <li>If the measured voltage is normal, replace the drive unit. See <a href="#">Replacing the drive unit on page 267</a>.</li> <li>If the measured voltage is abnormal, there is an issue with the 24 VDC supply from the power unit. See <a href="#">Troubleshooting the power unit on page 391</a>.</li> </ul>
7	Turn off power switch, and then restore the power connection between the drive unit and the power unit by reconnecting the power cable.	Make sure that the power cable is connected properly at both ends. <ul style="list-style-type: none"> <li>If the Module Status LED is green, the fault has been fixed. Proceed with step 1.</li> <li>If the Module Status LED is off, the fault remains. Proceed with step 6.</li> </ul>
8	Restore the communication between the modules by reconnecting the EtherCAT cables.	Make sure the EtherCAT cables are connected properly on both ends. <ul style="list-style-type: none"> <li>If the Link/Activity LED is yellow, the fault has been fixed. Proceed with step 1.</li> <li>If the Link/Activity LED is off, the fault remains. Replace the EtherCAT cables, see 9.</li> </ul>
9	Replace the EtherCAT cables.	<ul style="list-style-type: none"> <li>If the Link/Activity LED is yellow, the fault has been fixed. Proceed with step 1.</li> <li>If the Link/Activity LED is off, the fault remains. Replace the drive unit, see <a href="#">Replacing the drive unit on page 267</a>.</li> </ul>

Continues on next page

	Action	Note
10	Check the safety cable connection: X17.	<p>Make sure that the safety cable is connected properly on both ends.</p> <ul style="list-style-type: none"> <li>• If the connection seems OK, proceed with step <a href="#">5</a>.</li> <li>• If there is a problem with the connection, proceed with step <a href="#">11</a>.</li> </ul>
11	Restore the communication of the safety cable between the modules by reconnecting the cable X17.	<p>Make sure that the safety cable is connected properly on both ends.</p> <ul style="list-style-type: none"> <li>• If the connection seems OK, the fault has been fixed. Proceed with step <a href="#">1</a>.</li> <li>• If there is a problem with the connection, replace the safety related cables. See <a href="#">12</a>.</li> </ul>
12	Replace the safety cable: X17.	<ul style="list-style-type: none"> <li>• If the connection seems OK, the fault has been fixed. Proceed with step <a href="#">1</a>.</li> <li>• If the fault remains, see <a href="#">Troubleshooting the power unit on page 391</a>.</li> </ul>

## 7 Troubleshooting

### 7.3.4 Troubleshooting the additional drive unit

### 7.3.4 Troubleshooting the additional drive unit

#### Location

The illustration shows the location of the drive unit in the controller.

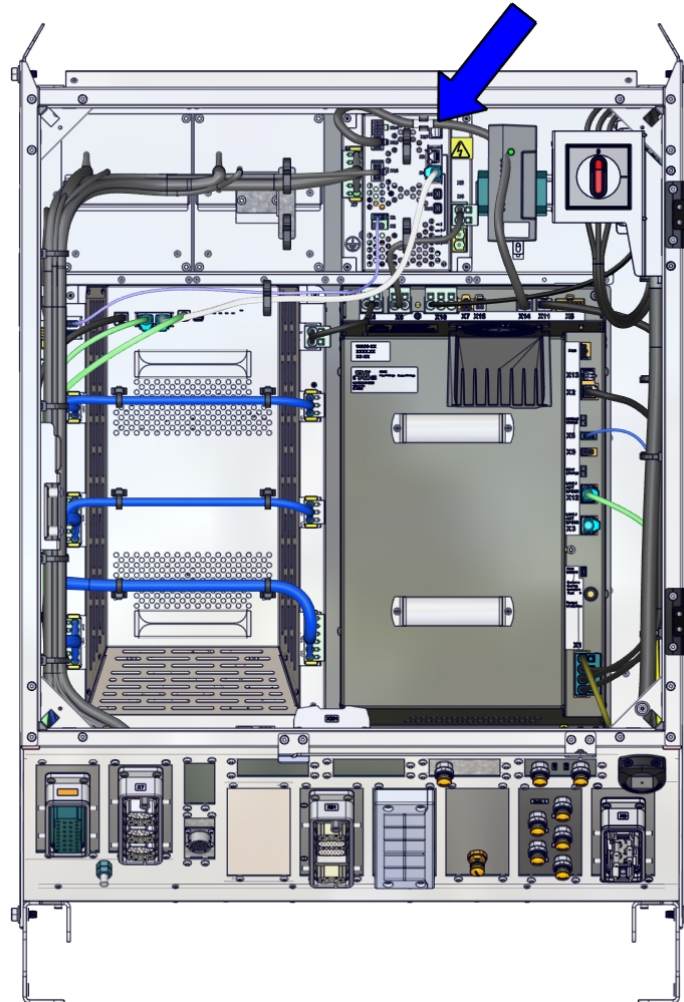

xx2200001056

*Continues on next page*

#### Positions

The power unit, drive unit, and additional drive units can be placed in the following positions in the controller:

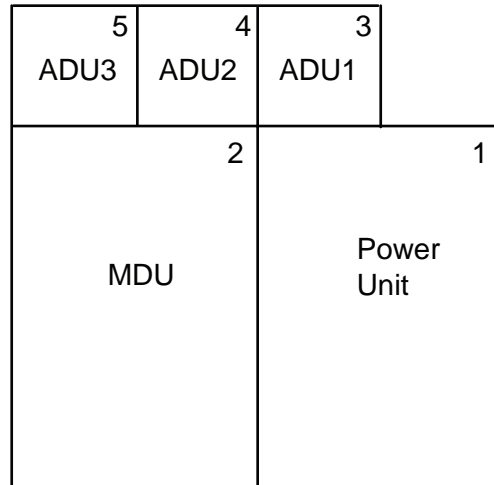

xx2300000976

See also *Application manual - Additional axes 3HAC082287-001*.

## 7 Troubleshooting

### 7.3.4 Troubleshooting the additional drive unit

Continued

#### LEDs

The illustration below shows the indication LEDs on the additional drive unit.

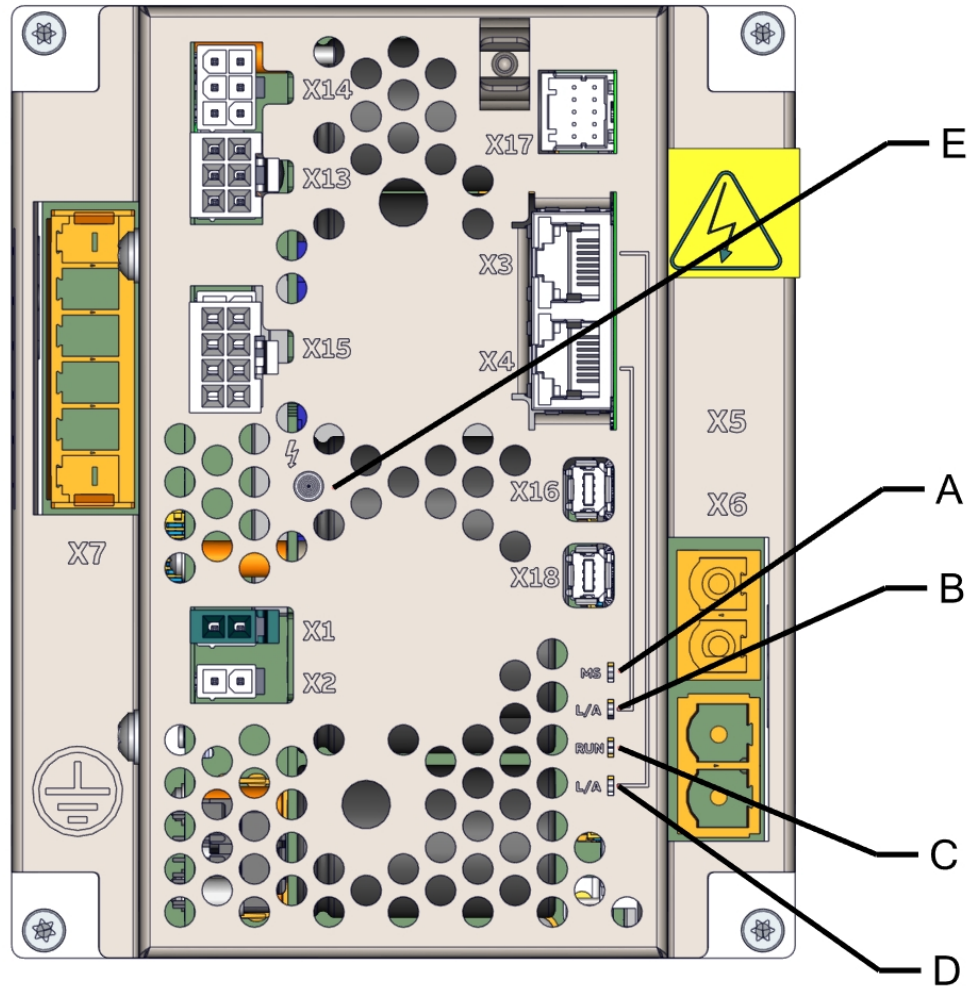

xx2200001052

Continues on next page

	Name	Description
A	MS (Module Status) LED	<p>The status indicator LED can be used to identify the following status during start-up/power on:</p> <ul style="list-style-type: none"> <li>• Red, steady: Default when power is available.</li> <li>• Red, flashing (~1Hz): Power is on, self-test is ongoing, operating system is loading.</li> <li>• Green, flashing (~1Hz): Application is loaded and waiting for communication.</li> <li>• Green, steady: Drive unit is operational.</li> </ul> <p>If the LED does not turn steady green after 30-60 sec, the status indicator LED can be used to identify the following issues:</p> <ul style="list-style-type: none"> <li>• No color: Power to the drive unit is missing.</li> <li>• Red, steady: Internal error.</li> <li>• Red, flashing (~1Hz): Firmware error or self-test failure.</li> <li>• Green, flashing (~1Hz): Communication error to another module.</li> </ul>
B	LA (Link Activity [0]) LED	<p>Shows the Link activity of the EtherCAT slave port 0.</p> <ul style="list-style-type: none"> <li>• Off: No link</li> <li>• Yellow flashing: Link and activity.</li> <li>• Yellow steady: Link without activity.</li> </ul>
C	RUN (EtherCAT RUN) LED	<p>Shows the actual state of the device state machine:</p> <ul style="list-style-type: none"> <li>• Off: Drive unit is in state INIT.</li> <li>• Green flashing (slow): Drive unit is in state PRE-OPERATIONAL.</li> <li>• Green single flash: Drive unit is in state SAFE-OPERATIONAL.</li> <li>• Green steady: Drive unit is in state OPERATIONAL.</li> <li>• Green flickering (fast): Drive unit is in state BOOTSTRAP.</li> </ul>
D	LA (Link Activity [1]) LED	<p>Shows the Link activity of the EtherCAT slave port 1.</p> <ul style="list-style-type: none"> <li>• Off: No link</li> <li>• Yellow flashing: Link and activity.</li> <li>• Yellow steady: Link without activity.</li> </ul>
E	DC-BUS High Voltage LED	<ul style="list-style-type: none"> <li>• No color: Voltage between DC+ - DC- &lt; 60 VDC</li> <li>• Yellow: Voltage between DC+ - DC- &gt; 60 VDC</li> </ul>

#### Required test equipment

Equipment needed for troubleshooting:

Equipment	Note
Multimeter	
Insulating gloves	

*Continues on next page*

## 7 Troubleshooting

### 7.3.4 Troubleshooting the additional drive unit

Continued

Equipment	Note
Circuit diagram - OmniCore V250XT, rev 04 or later	3HAC074000-008

#### Preparations

	Action
1	Check the FlexPendant for errors and warnings.
2	Power the controller off. Wait one minute, power the controller on.
3	Wait 30-60 seconds after power-on. Make sure that the control system power is in run-time mode.

#### Troubleshooting flowchart

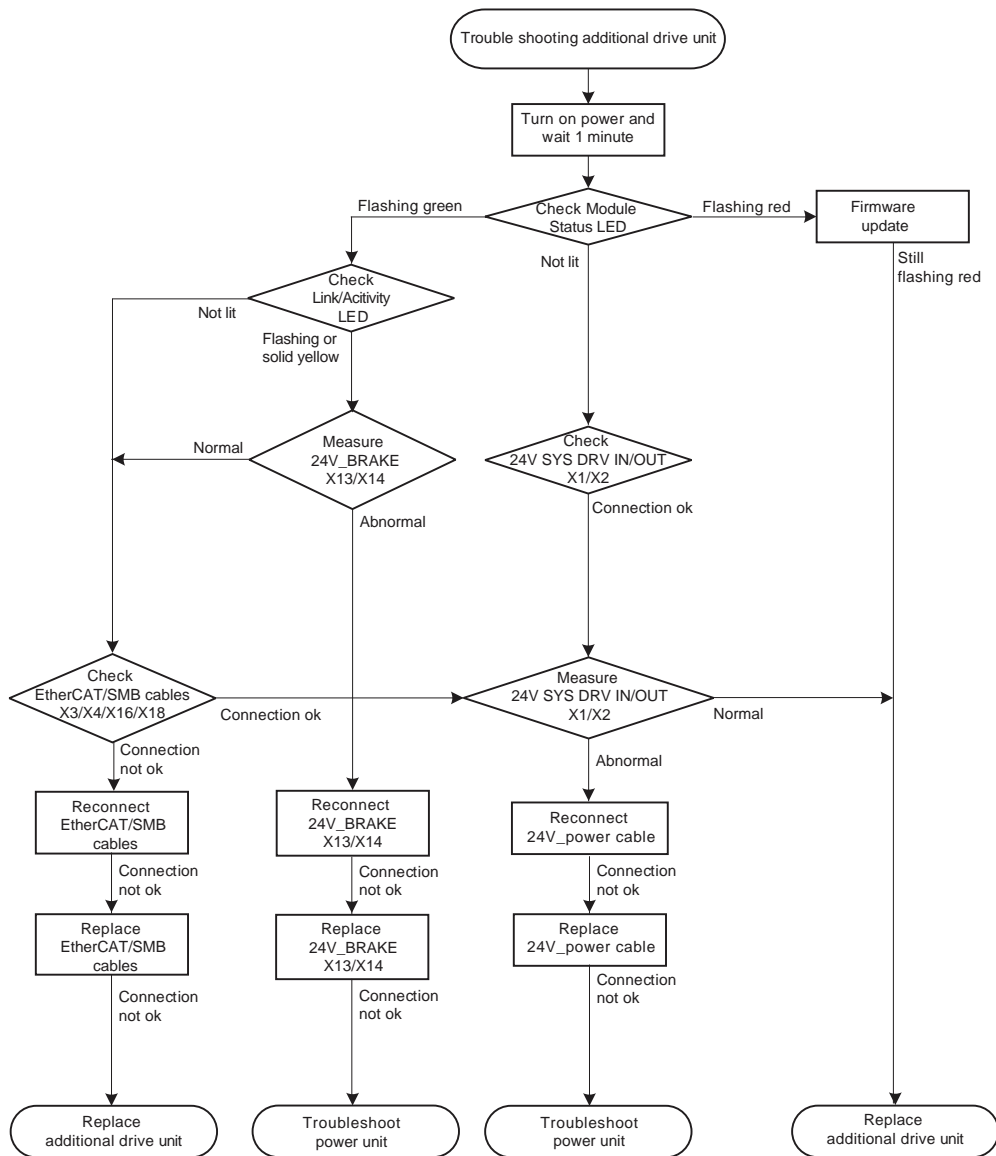

xx2200001226

Continues on next page



### Troubleshooting procedure

The troubleshooting table is supposed to be used as a detailed instruction together with the troubleshooting flowchart.



#### Tip

In setups with several additional drive units:

- Measure voltage on the last unit in the chain first, and then work your way backwards.
- Check if the FlexPendant indicates which unit is faulty. If not, replace one unit at a time.

	Action	Note
1	Power on the controller. Check the Module Status LED (A) on the additional drive unit.	<p>Make sure that the additional drive unit is operational.</p> <p>Wait at least 1 min after power-on.</p> <p>If the Module Status LED is:</p> <ul style="list-style-type: none"> <li>• Off: The additional drive unit is in the power off state. Proceed with step 4.</li> <li>• Flashing red (~ 1Hz): Firmware error or self-test failure.</li> </ul> <p>Upgrade the firmware. If the problem persists, the additional drive unit may be faulty, see <a href="#">Replacing the additional drive unit on page 272</a>.</p> <ul style="list-style-type: none"> <li>• Flashing green (~ 1Hz): Communication error to another module. Proceed with step 3.</li> </ul>
2	Measure the 24V_BRAKE input at connector X13/X14.   <b>Note</b> The brake current is displayed on the FlexPendant, in the <b>Settings</b> app under <b>Hardware Devices -&gt; Runtime Information</b> .	<p>Verify that the input to X13/X14 is 24 VDC <math>\pm</math> 10%.</p> <ul style="list-style-type: none"> <li>• If the measured voltage is normal, proceed with step 5.</li> <li>• If the measured voltage is abnormal, proceed with step 11.</li> </ul>
3	Check the two Link/Activity LEDs (B & D). These LEDs indicate the communication status of the module.	<p>Make sure that the drive unit is operational.</p> <p>If the Link/Activity LED is:</p> <ul style="list-style-type: none"> <li>• Yellow, steady: The communication link is established. The drive unit may be faulty, see <a href="#">Replacing the additional drive unit on page 272</a>.</li> <li>• Flashing yellow: The communication link is established and data is transferred through the port. Proceed with step 2.</li> <li>• Off: The EtherCAT link is not established. Proceed with step 5.</li> </ul>
4	Check the connectors at T41.X1 (24V SYS DRV IN) and T41.X2 (24V SYS DRV OUT). Make sure that the power cables are connected properly at both ends.	<p>If the connection and cable seem OK, proceed with step 6.</p> <p>If there is a problem with the connection, proceed with step 7.</p>

Continues on next page

## 7 Troubleshooting

### 7.3.4 Troubleshooting the additional drive unit

Continued

	Action	Note
5	Check the EtherCAT/SMB cables X3/X4/X16/X18. Make sure that the cables are connected properly at both ends.	If the connection seems OK, proceed with step 6. If there is a problem with the connection, proceed with step 9.
6	Measure the 24VDC SYS DRV input at connector X1/X2.	Verify that the input to X1/X2 is 24 VDC $\pm$ 10%. <ul style="list-style-type: none"> <li>If the measured voltage is normal, replace the drive unit. See <a href="#">Replacing the additional drive unit on page 272</a>.</li> <li>If the measured voltage is abnormal, proceed with step 7.</li> </ul>
7	Restore the power connection between the drive unit and the power unit by reconnecting the 24V_power cable.	Make sure that the 24V_power cable is connected properly at both ends. <ul style="list-style-type: none"> <li>If the Module Status LED is green, the fault has been fixed. Proceed with step 1.</li> <li>If the Module Status LED is off, the fault remains. Proceed with step 8.</li> </ul>
8	Replace the the 24V_power cable between the drive unit and the power unit.	<ul style="list-style-type: none"> <li>If the Module Status LED is green, the fault has been fixed. Proceed with step 1.</li> <li>If the Module Status LED is off, there is an issue with the 24 VDC supply from the power unit. See <a href="#">Troubleshooting the power unit on page 391</a>.</li> </ul>
9	Restore the communication between the modules by reconnecting the EtherCAT/SMB cables.	Make sure the EtherCAT cables are connected properly on both ends. <ul style="list-style-type: none"> <li>If the Link/Activity LED is yellow, the fault has been fixed. Proceed with step 1.</li> <li>If the Link/Activity LED is off, the fault remains. Proceed with step 10.</li> </ul>
10	Replace the EtherCAT/SMB cables.	<ul style="list-style-type: none"> <li>If the Link/Activity LED is yellow, the fault has been fixed. Proceed with step 1.</li> <li>If the Link/Activity LED is off, the fault remains. Replace the drive unit, see <a href="#">Replacing the additional drive unit on page 272</a>.</li> </ul>
11	Restore the communication by reconnecting the 24V_BRAKE cables X13/X14.	Make sure that the cables are connected properly on both ends. <ul style="list-style-type: none"> <li>If the connection seems OK, the fault has been fixed. Proceed with step 1.</li> <li>If there is a problem with the connection, proceed with step 12.</li> </ul>
12	Replace the 24V_BRAKE cables X13/X14.	<ul style="list-style-type: none"> <li>If the connection seems OK, the fault has been fixed. Proceed with step 1.</li> <li>If the fault remains, see <a href="#">Troubleshooting the power unit on page 391</a>.</li> </ul>

7.3.5 Troubleshooting the power unit

Location

The illustration below shows the location of the power unit in the controller.

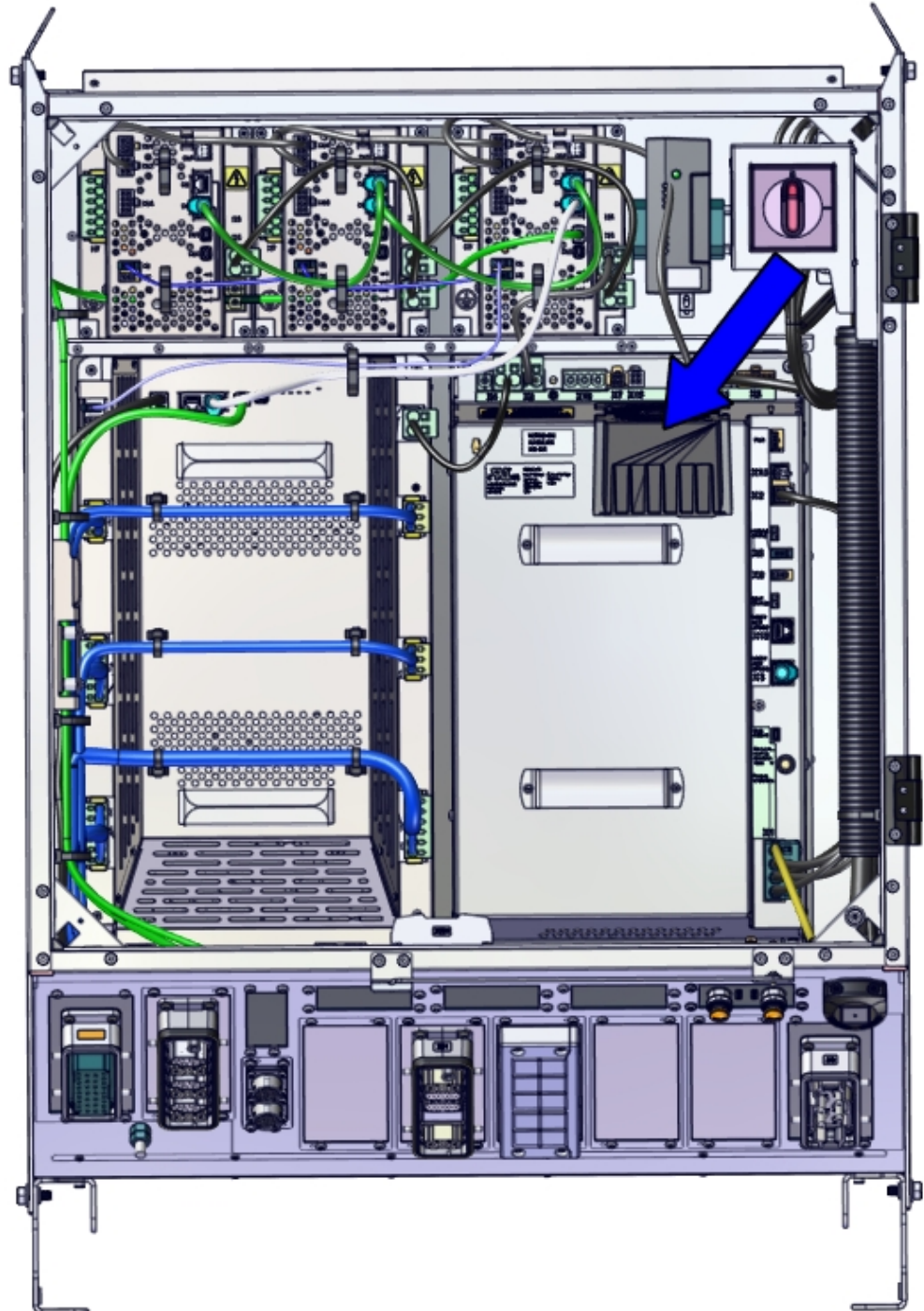

xx2300001838

*Continues on next page*

## 7 Troubleshooting

### 7.3.5 Troubleshooting the power unit

Continued

#### LEDs

The illustration below shows the LEDs on the power unit.

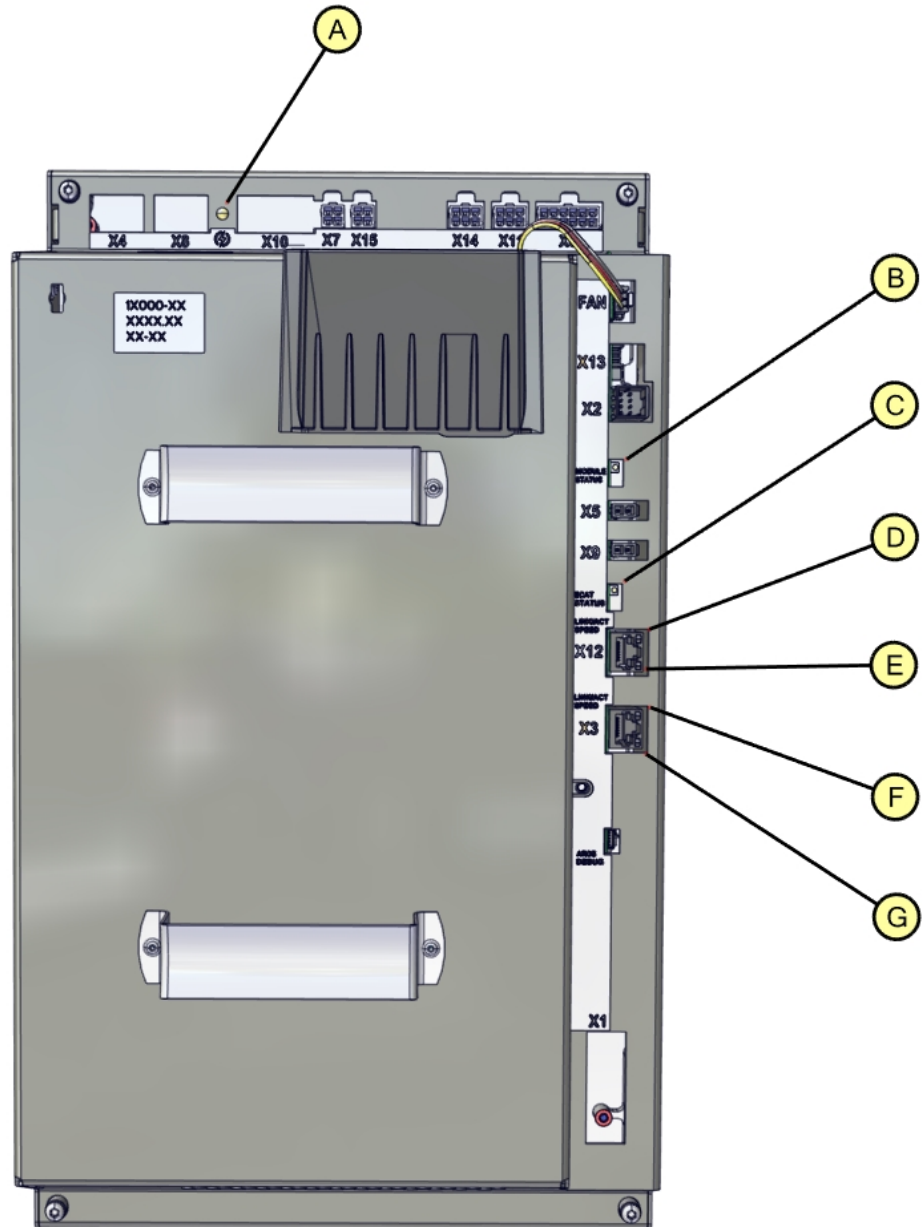

xx2100001070

	Name	Description
A	DC-BUS High Voltage LED	<ul style="list-style-type: none"><li>No color: Voltage between DC+ - DC- &lt; 60 VDC</li><li>Yellow: Voltage between DC+ - DC- &gt; 60 VDC</li></ul>

Continues on next page

	Name	Description
B	MODULE STATUS	The Module status LED indicates the following: <ul style="list-style-type: none"> <li>No color: AC_IN is missing or 24V_TRUNK is not available.</li> <li>Red, flashing: Performing self test.</li> <li>Red, steady: An error has occurred and unit is in error state.</li> <li>Green, flashing: Unit is waiting for 24V_SYS and internal communication.</li> <li>Green, steady: Unit is in operational state. Activating CTRL inputs in this state will charge DC_OUT.</li> </ul>
C	ECAT STATUS	The EtherCAT Device State LED/RUN LED displays the actual state of the device state machine. The run state is as follows: <ul style="list-style-type: none"> <li>Off: Power unit is in state INIT.</li> <li>Green flashing (slow): Power unit is in state PRE-OPERATIONAL.</li> <li>Green single flash: Power unit is in state SAFE-OPERATIONAL.</li> <li>Green steady: Power unit is in state OPERATIONAL.</li> <li>Green flickering (fast): Power unit is in state BOOTSTRAP.</li> </ul>
D	SPEED	Shows the network communication speed. <ul style="list-style-type: none"> <li>Green steady: Speed is 100 Mbps.</li> <li>Off: Speed is 10 Mbps.</li> </ul>
E	LINK/ACT	Shows the Link activity of the EtherCAT slave port 1. <ul style="list-style-type: none"> <li>Off: No link</li> <li>Yellow flashing: Link and activity.</li> <li>Yellow steady: Link without activity.</li> </ul>
F	SPEED	Shows the network communication speed. <ul style="list-style-type: none"> <li>Green steady: Speed is 100 Mbps.</li> <li>Off: Speed is 10 Mbps.</li> </ul>
G	LINK/ACT	Shows the Link activity of the EtherCAT slave port 0. <ul style="list-style-type: none"> <li>Off: No link</li> <li>Yellow flashing: Link and activity.</li> <li>Yellow steady: Link without activity.</li> </ul>

#### Required test equipment

Equipment needed for troubleshooting:

Equipment	Note
Multimeter	
Insulating gloves	
<i>Circuit diagram - OmniCore V250XT, rev 04 or later</i>	<i>3HAC074000-008</i>

*Continues on next page*

# 7 Troubleshooting

## 7.3.5 Troubleshooting the power unit

Continued

### Preparations

Action	
1	Check the FlexPendant for errors and warnings.
2	Power the controller off. Wait one minute, power the controller on.
3	Wait 30-60 seconds after power-on. Make sure that the control system power is in run-time mode.

### Troubleshooting flowchart

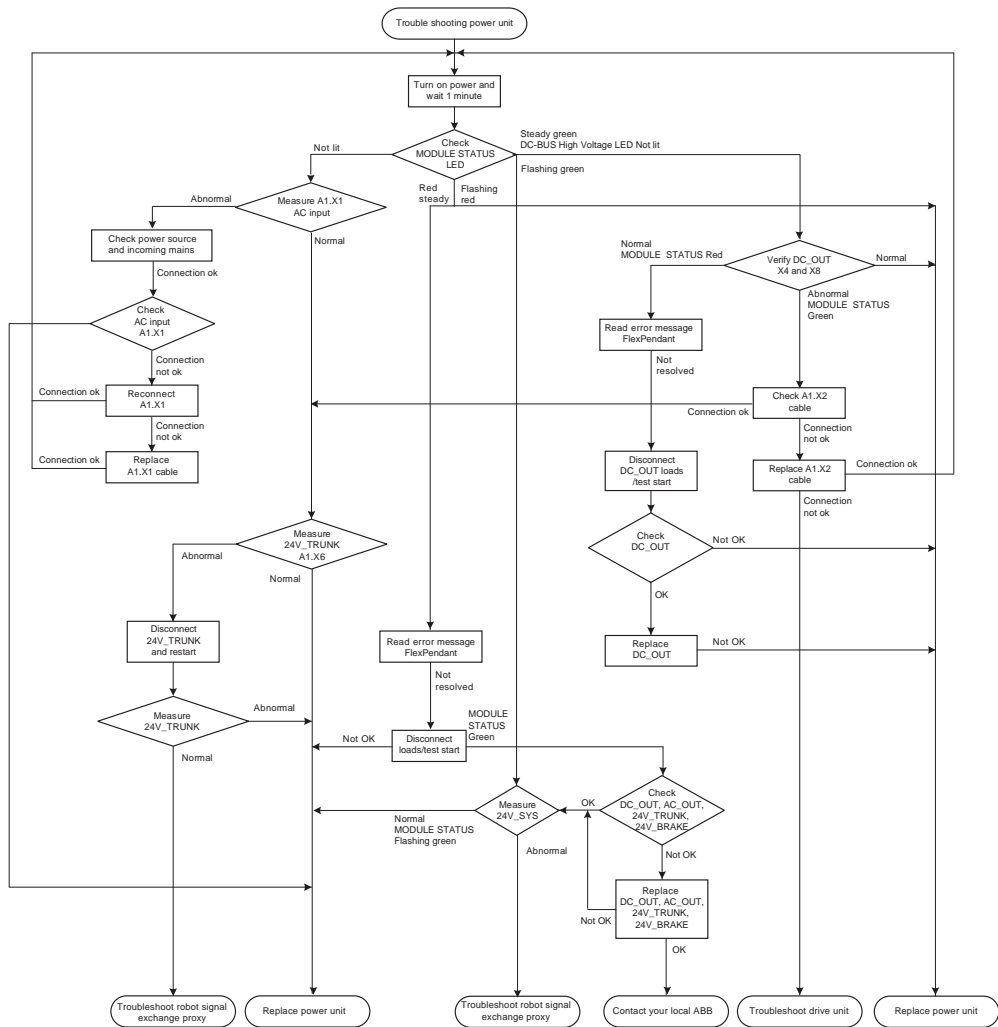

xx2100001981

Continues on next page

## Troubleshooting procedure

The troubleshooting table is supposed to be used as a detailed instruction together with the troubleshooting flowchart.

	Action	Note
1	Make sure the power has been off for more than 10 seconds. Power on the controller. Check the MODULE STATUS LED on the power unit.	Make sure that the power unit is operational. Wait at least 1 min after power-on. If the MODULE STATUS LED is: <ul style="list-style-type: none"> <li>• Off: The power unit is in the power off state. Proceed with step 2.</li> <li>• Red, steady: Internal error. Proceed with step 7.</li> <li>• Flashing red (~ 1Hz): Firmware error or self-test failure. The power unit may be faulty, see <a href="#">Replacing the power unit on page 249</a>.</li> <li>• Flashing green (~ 1Hz): Internal communication error or 24V_SYS_DRV is missing. Proceed with step 11.</li> <li>• Steady green but DC-BUS High Voltage LED is off: Proceed with step 12.</li> </ul>
2	Verify AC_IN.	Verify that the input to A1.X1 is 380-480V AC. <ul style="list-style-type: none"> <li>• If AC_IN is between 380-480V AC, proceed with step 5.</li> <li>• If AC_IN is abnormal, there is an issue with A1.X1. Proceed with step 3.</li> </ul>
3	Check the connector at A1.X1 (AC input). Make sure that the power cables are connected properly at both ends.	If the connection seems OK, proceed with step 5. If there is a problem with the connection, proceed with step 4.
4	Replace AC input cable A1.X1.	If the connection seems OK, proceed with step 5. If there is a problem with the connection, check power source and incoming mains. Make sure that AC_IN is OK.
5	Measure the 24VDC_TRUNK at connector A1.X6.	Verify that the input to A1.X6 is 25.2 VDC +/- 5%. <ul style="list-style-type: none"> <li>• If the measured voltage is normal and MODULE STATUS LED is green, proceed with step 7.</li> <li>• If the measured voltage is normal and MODULE STATUS LED is off, the unit may be faulty, see <a href="#">Replacing the power unit on page 249</a>.</li> <li>• If the measured voltage is abnormal, proceed with step 6.</li> </ul>

Continues on next page

## 7 Troubleshooting

### 7.3.5 Troubleshooting the power unit

Continued

	Action	Note
6	Disconnect A1.X6 24VDC_TRUNK from the power unit and restart.	<p>Turn off power to the unit for 10 seconds and restart. Check if the 24VDC_TRUNK voltage has recovered.</p> <p>Verify that the input to A1.X6 is 25.2 VDC -5%, +5%.</p> <ul style="list-style-type: none"> <li>• If the measured voltage is normal with A1.X6 disconnected, the load attached to the power unit is causing the unit to trip, see .</li> <li>• If the measured voltage is abnormal with A1.X6 disconnected, the unit may be faulty, see <a href="#">Replacing the power unit on page 249</a>.</li> </ul>
7	Check error message on FlexPendant and take appropriate action.	<ul style="list-style-type: none"> <li>• If the error message is insufficient, proceed with step 8.</li> <li>• If an error was resolved, restart from step 1.</li> </ul>
8	Disconnect loads and test start.	<p>Turn off power for 10 seconds.</p> <p>Disconnect the following loads:</p> <ul style="list-style-type: none"> <li>• DC_OUT (X4 and X8, Drive unit)</li> <li>• AC_OUT (X7 and X15, External AC Supply to customer power supply)</li> <li>• 24VDC_TRUNK (X6, Robot signal exchange proxy)</li> <li>• 24V_BRAKE (X11 and X14, Drive unit)</li> </ul> <p>Turn on power again.</p> <ul style="list-style-type: none"> <li>• If the MODULE STATUS LED is green with the loads disconnected, Proceed with step 9.</li> <li>• If the fault remains, the unit may be faulty, see <a href="#">Replacing the power unit on page 249</a>.</li> </ul>
9	<p>Make sure that the cables are connected properly at both ends:</p> <ul style="list-style-type: none"> <li>• DC_OUT (X4 and X8)</li> <li>• AC_OUT (X7 and X15)</li> <li>• 24VDC_TRUNK (X6)</li> <li>• 24V_BRAKE (X11 and X14)</li> </ul>	<p>If the connection and cables seem OK, proceed with step 11.</p> <p>If there is a problem with the connection, proceed with step 10.</p>
10	<p>Replace cables:</p> <ul style="list-style-type: none"> <li>• DC_OUT (X4 and X8)</li> <li>• AC_OUT (X7 and X15)</li> <li>• 24VDC_TRUNK (X6)</li> <li>• 24V_BRAKE (X11 and X14)</li> </ul>	<p>If the connection and cables seem OK, proceed with step 11.</p> <p>If there is a problem with the connection, the connected loads are out of specification. Contact your local ABB.</p>
11	Verify 24V_SYS_DRV.	<p>Verify that 24V_SYS_DRV IN (X9) is stable at 24 VDC (18VDC – 26.4VDC).</p> <ul style="list-style-type: none"> <li>• If the measured voltage is normal and MODULE STATUS LED is flashing green, the unit has internal communication error, see <a href="#">Replacing the power unit on page 249</a>.</li> <li>• If the measured voltage is abnormal, see .</li> </ul>

Continues on next page



	Action	Note
12	Activate safe CTRL signals and verify DC_OUT.	<p>Verify VDC for DC_OUT (X4):</p> <p>For DSQC3070 (HV 3x380-480V), verify that DC_OUT (X4) is 650 +/- 3% VDC.</p> <p>For DSQC3069 (LV 3x380-480V), verify that DC_OUT (X4) is 370 +/- 3% VDC.</p> <ul style="list-style-type: none"> <li>• If the measured voltage is normal, the unit might be faulty. See <a href="#">Replacing the power unit on page 249</a>.</li> <li>• If the measured voltage is normal and MODULE STATUS LED is steady red, read error messages on FlexPendant and take action. Proceed with step 13.</li> <li>• If the measured voltage is abnormal and MODULE STATUS LED is steady green, proceed with step 15.</li> </ul>
13	Check error message on FlexPendant and take appropriate action.	<ul style="list-style-type: none"> <li>• If the error message is insufficient, proceed with step 14.</li> <li>• If an error was resolved, restart from step 1.</li> </ul>
14	Test starting with DC_OUT loads disconnected.	<ol style="list-style-type: none"> <li>1 Turn off power for 10 seconds.</li> <li>2 Disconnect DC_OUT (X4 and X8).</li> <li>3 Turn on power again.</li> <li>4 Activate CTRL signals.</li> <li>5 The DC-BUS High Voltage LED should turn yellow/orange and DC_OUT should be charged to nominal voltage.</li> <li>6 Verify that the disconnected load is within specification and is not broken.</li> </ol> <ul style="list-style-type: none"> <li>• If DC_OUT is OK and DC-BUS High Voltage is on with the loads disconnected, proceed with step 17.</li> <li>• If DC_OUT is not OK, the unit may be faulty, see <a href="#">Replacing the power unit on page 249</a>.</li> </ul>
15	Make sure that the cables are connected properly at both ends: <ul style="list-style-type: none"> <li>• CTRL/FB (A1.X2)</li> </ul>	<p>If the connection and cables seem OK, proceed with step 11.</p> <p>If there is a problem with the connection, proceed with step 16.</p>
16	Replace cables: <ul style="list-style-type: none"> <li>• CTRL/FB (A1.X2)</li> </ul>	<p>If the connection and cables seem OK, restart from step 1.</p> <p>If there is a problem with the connection, see <a href="#">Troubleshooting the drive unit on page 378</a>.</p>
17	Make sure that the cables are connected properly at both ends: <ul style="list-style-type: none"> <li>• DC_OUT (X4 and X8)</li> </ul>	<p>If the connection and cables seem OK, proceed with step 18.</p> <p>If DC_OUT is not OK, the unit may be faulty, see <a href="#">Replacing the power unit on page 249</a>.</p>
18	Replace cables: <ul style="list-style-type: none"> <li>• DC_OUT (X4 and X8)</li> </ul>	<p>If DC_OUT is not OK, the unit may be faulty, see <a href="#">Replacing the power unit on page 249</a>.</p>

## 7 Troubleshooting

### 7.3.6 Troubleshooting the HVLP power unit (DSQC3072)

### 7.3.6 Troubleshooting the HVLP power unit (DSQC3072)

#### Location

The illustration below shows the location of the power unit in the controller.

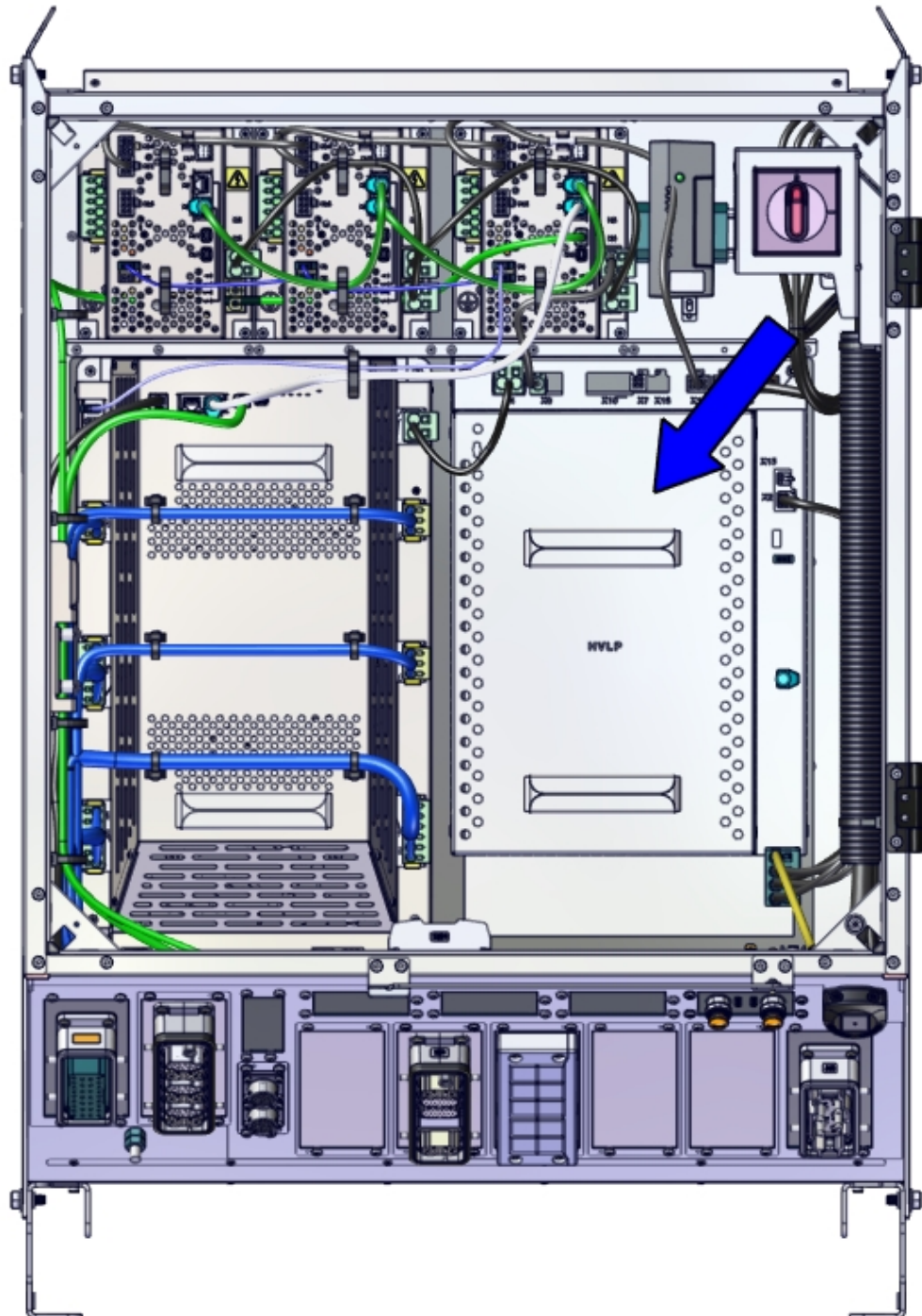

xx2300001991

*Continues on next page*

LEDs

The illustration below shows the LEDs on the power unit.

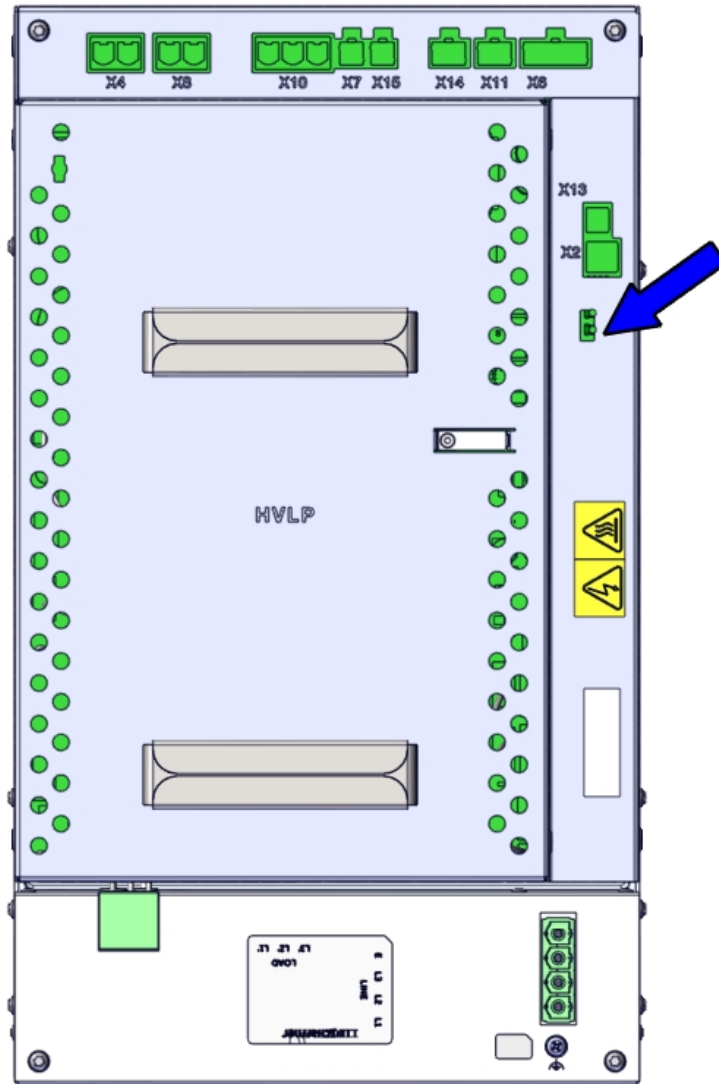

xx2300001469

Continues on next page

## 7 Troubleshooting

### 7.3.6 Troubleshooting the HVLP power unit (DSQC3072)

Continued

Name	Description
Module Status	<p>The status indicator LED can be used to identify the following status during startup/power on:</p> <ul style="list-style-type: none"><li>• Red, steady: Default when power is available.</li><li>• Red, flashing (~1Hz): Power is on, self-test is ongoing, operating system is loading.</li><li>• Green, flashing (~1Hz): Application is loaded and waiting for communication.</li><li>• Green, steady: Unit is operational.</li></ul> <p>If the LED does not turn steady green after 30-60 sec, the status indicator LED can be used to identify the following issues:</p> <ul style="list-style-type: none"><li>• No color: Power to the power unit is missing.</li><li>• Red, steady: Internal error.</li><li>• Red, flashing (~1Hz): Firmware error or self-test failure.</li><li>• Green, flashing (~1Hz): Communication error to another module.</li><li>• Green, steady: Unit is operational.</li></ul>

#### Required test equipment

Equipment needed for troubleshooting:

Equipment	Note
Multimeter	
Insulating gloves	
Circuit diagram - OmniCore V250XT, rev 04 or later	3HAC074000-008

#### Preparations

	Action
1	Check the FlexPendant for errors and warnings.
2	Power the controller off. Wait one minute, power the controller on.
3	Wait 30-60 seconds after power-on. Make sure that the control system power is in run-time mode.

Continues on next page

Troubleshooting flowchart

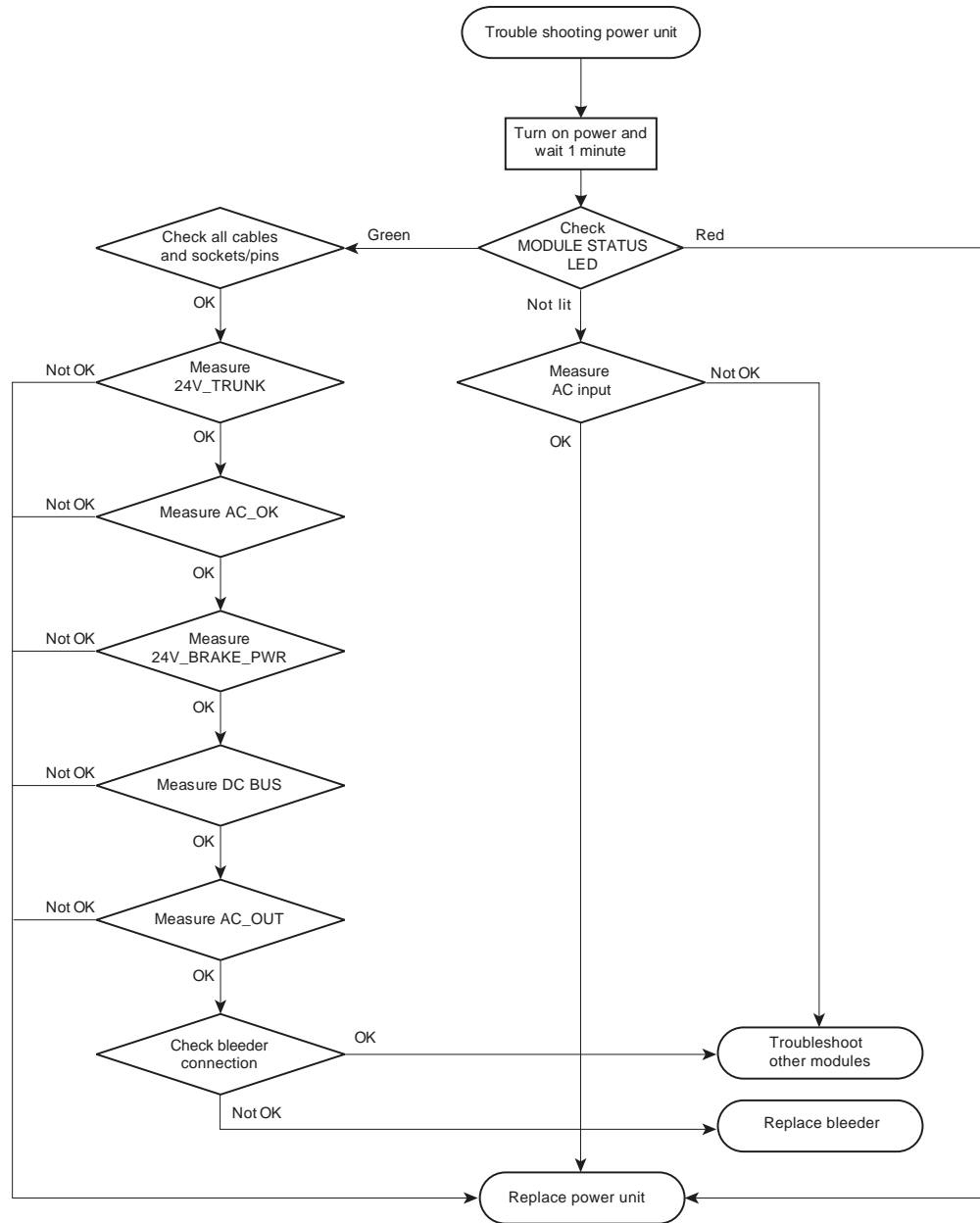

xx2300001468

Troubleshooting procedure

The troubleshooting table is supposed to be used as a detailed instruction together with the troubleshooting flowchart.

	Action	Note
1	Power on the controller. Check the MODULE STATUS LED on the power unit.	Make sure that the power unit is operational. Wait at least 1 min after power-on. If the MODULE STATUS LED is: <ul style="list-style-type: none"> <li>• If the LED is green, proceed with step 2.</li> <li>• If the LED is not lit, proceed with step 4.</li> <li>• If the LED is red, proceed with step 11.</li> </ul>

Continues on next page

## 7 Troubleshooting

### 7.3.6 Troubleshooting the HVLP power unit (DSQC3072)

Continued

	Action	Note
2	Make sure that the cables are connected properly at both ends and that all sockets/pins are in the correct position.	If the connection and cables seem OK, proceed with step 3.
3	Measure the 24V_TRUNK voltage at X6.	Verify that the input to 24V_TRUNK is 25.2 VDC +/- 5%. <ul style="list-style-type: none"><li>• If the 24V_TRUNK voltage is within the range, proceed with step 5.</li><li>• If the 24V_TRUNK voltage is abnormal, proceed with step 11.</li></ul>
4	Measure the AC input voltage.	Measure the voltage of L1\L2\L3 to E. The AC input voltage should be within 380-480 Vrms (-15%~10%) and same with field grid voltage. <ul style="list-style-type: none"><li>• If the AC input voltage is normal, proceed with step 11.</li><li>• If the AC input voltage is abnormal, proceed with step 8.</li></ul>
5	Measure the AC_OK signal at X13.	Verify that the voltage on X13 is 0 V. <ul style="list-style-type: none"><li>• If the AC_OK signal is greater than 22 V, proceed with step 11.</li><li>• If the AC_OK signal is lower than 1 V, proceed with step 6.</li></ul>
6	Measure the 24V_BRAKE_PWR voltage at X11/X14.	Verify that the input to 24V_BRAKE_PWR is 25.2 VDC +/- 5%. <ul style="list-style-type: none"><li>• If the 24V_BRAKE_PWR voltage is in the range, proceed with step 7.</li><li>• If the 24V_BRAKE_PWR voltage is abnormal, proceed with step 11.</li></ul>
7	Measure the DC BUS voltage at X4/X8.	Verify that DC BUS (X4/X8) is 650 +/- 3% VDC. <ul style="list-style-type: none"><li>• If the DC BUS voltage is normal, troubleshoot other modules.</li><li>• If the DC BUS voltage is abnormal, proceed with step 11.</li></ul>
8	Check the connection from power inlet to the power module.	Check connection between controller power inlet and power module. <ul style="list-style-type: none"><li>• If the connection is OK, proceed with step 11.</li><li>• If there is a problem with the connection, repair the connection and start over.</li></ul>
9	Measure the AC_OUT voltage at X7/X15.	Verify that AC_OUT (X7/X15) is 230 +/- 10% VDC. <ul style="list-style-type: none"><li>• If the AC_OUT voltage is normal, troubleshoot other modules.</li><li>• If the AC_OUT voltage is abnormal, proceed with step 11.</li></ul>

Continues on next page

	Action	Note
10	<p>Check the bleeder connection at X10.</p> <p> <b>CAUTION</b></p> <p>Before measuring the bleeder resistance, do the following:</p> <ul style="list-style-type: none"> <li>• Shut down the power and wait 1 minute.</li> <li>• Disconnect X10.</li> </ul>	<p>Measure the resistance between bleeder connector (X10.1 and X10.2)</p> <ul style="list-style-type: none"> <li>• If the connection is OK, proceed with step 11.</li> <li>• If there is a problem with the connection, repair the connection and start over.</li> <li>• If the resistance of bleeder is greater than 20 ohm or less than 10 ohm, replace the bleeder. See <a href="#">Replacing the break resistor bleeder on page 289</a>.</li> </ul>
11	The unit may be faulty. Replace the power unit.	See <a href="#">Replacing the power unit on page 249</a> .

## 7 Troubleshooting

---

### 7.3.7 Troubleshooting fieldbuses and I/O

### 7.3.7 Troubleshooting fieldbuses and I/O

---

#### Further information

Information about how to troubleshoot the fieldbuses and I/O units can be found in the manual for the respective fieldbus or I/O unit. See [References on page 10](#).



### 7.3.8 Troubleshooting the 3G Connected Services gateway

#### Location

The illustration shows the location of the Connected Services gateway in the controller.

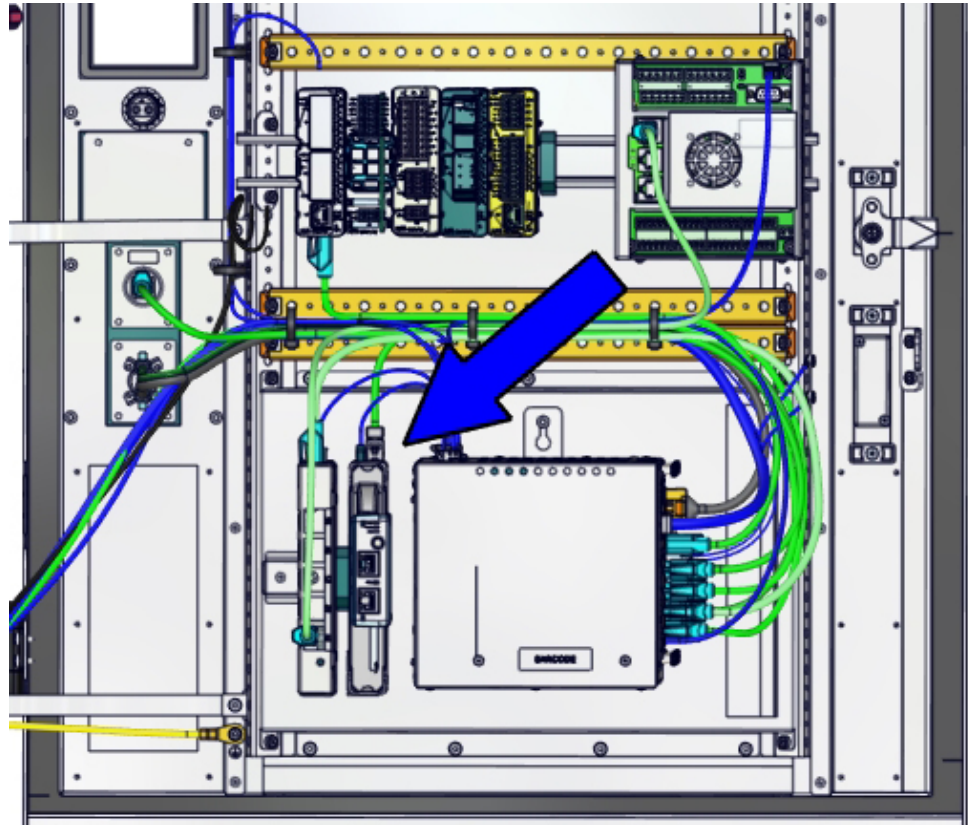

xx2300001805

*Continues on next page*

## 7 Troubleshooting

### 7.3.8 Troubleshooting the 3G Connected Services gateway

*Continued*

#### LEDs for options 3G or WiFi

The illustration below shows the LEDs on the Connected Services gateway (3G or WiFi).

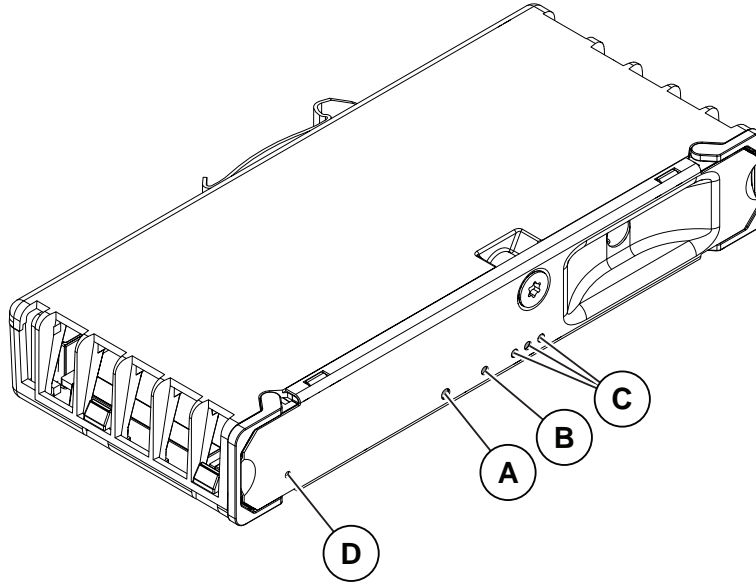

xx180000634

A	STATUS LED
B	LINK, 3G status or WiFi status LED
C	RF, signal strength status LEDs
D	Factory reset pin hole

Description	Significance
STATUS LED (red/green)	<p>Startup sequence:</p> <ol style="list-style-type: none"> <li>1 Red continuously: Default at power up.</li> <li>2 Red, flashing: Power on self-test ongoing, operating system is loading.</li> <li>3 Green flashing: Loading application.</li> <li>4 Green solid: Startup completed OK.</li> </ol> <p>If the LED does not turn steady green after 30-60sec, it can be used to identify the following issues:</p> <p>Fault indication:</p> <ul style="list-style-type: none"> <li>• No color: Power to the unit is missing.</li> <li>• Red, solid or flashing for more than 120s: Internal error. Try a pin reset, if problem persists replace the unit.</li> <li>• Green, flashing continuously: Communication error to another module, view error messages.</li> </ul>
LINK	<p>For the Connected Services 3G, an orange LED indicator, externally visible on the front, indicates the status of the 3G connection.</p> <p>Orange:</p> <ul style="list-style-type: none"> <li>• ON, flashing: 3G modem on, searching network.</li> <li>• ON, solid: 3G modem on and connected to network.</li> </ul>

*Continues on next page*

Description	Significance
LINK	For the connected services Wi-Fi, an orange LED indicator, externally visible on the front, indicates the status of the Wi-Fi connection. Orange: <ul style="list-style-type: none"> <li>• ON, flashing: Wi-Fi transceiver on, searching network.</li> <li>• ON, solid: Wi-Fi transceiver on and connected to network.</li> </ul>
RF, signal strength status LEDs	Three (3) LEDs indicating the Wi-Fi or 3G signal level. <ul style="list-style-type: none"> <li>• ON: The unit is connected to the network and working ok.</li> <li>• OFF: Problem with connector, antenna, or sim card.</li> </ul>
Reset pin hole	The reset pin hole can be used as follows: <ul style="list-style-type: none"> <li>• Short press (less than 5s): The module will reboot to reinitiate communication.</li> <li>• Long press (more than 5s): The module will be reset to factory status before restarting.</li> </ul>

#### Required test equipment

Equipment needed for troubleshooting:

Equipment	Note
Multimeter	
Insulating gloves	

#### Preparations

	Action
1	Check the FlexPendant for errors and warnings.
2	Power the controller off. Wait one minute, power the controller on.
3	Wait 30-60 seconds after power-on. Make sure that the control system power is in run-time mode.

*Continues on next page*

## 7 Troubleshooting

### 7.3.8 Troubleshooting the 3G Connected Services gateway

Continued

#### Troubleshooting flowchart for options 3G or WiFi

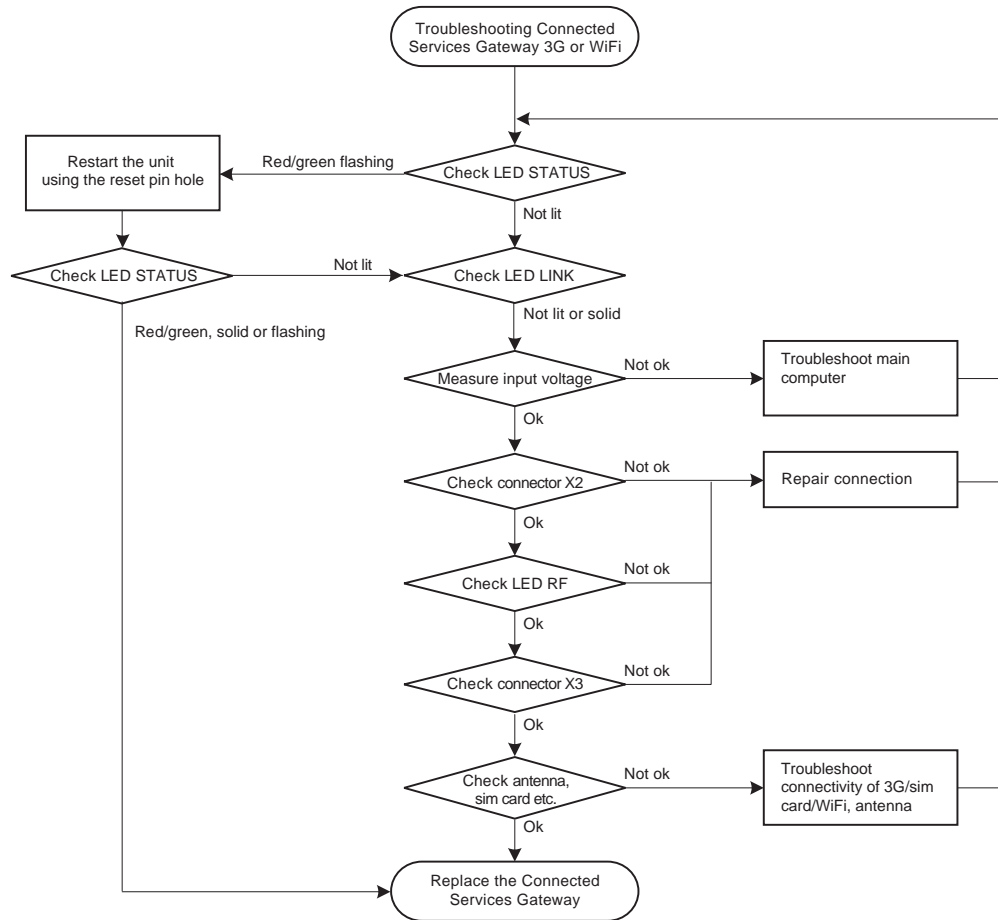

xx2300001646



#### Troubleshooting procedure for options 3G or WiFi

The troubleshooting table is supposed to be used as a detailed instruction together with the troubleshooting flowchart.

	Action	Note
1	Check the STATUS LED on the Connected Services Gateway.	If the LED is: <ul style="list-style-type: none"> <li>Red/green, flashing: proceed with step 2.</li> <li>OFF, the unit is faulty, or it does not have sufficient input voltage, or the connection of the connector X2 is not ok. Proceed with step 5.</li> </ul>
2	Reset the module to factory using the reset pin hole for more than 5s, and restart the controller.	Proceed with step 3.
3	Check the STATUS LED on the Connected Services Gateway.	If the LED is: <ul style="list-style-type: none"> <li>Red/green, flashing: An internal error has occurred, proceed with step 13.</li> <li>OFF, the unit is faulty, or it does not have sufficient input voltage, or the connection of the connector X2 is not ok. Proceed with step 5.</li> </ul>

Continues on next page

7.3.8 Troubleshooting the 3G Connected Services gateway  
Continued

	Action	Note
4	Check the LINK LED on the Connected Services Gateway.	If the LED is: <ul style="list-style-type: none"> <li>• OFF, the unit is faulty, or it does not have sufficient input voltage, or the connection of the connector X2 is not ok. Proceed with step 5.</li> <li>• Flashing: An internal error has occurred, proceed with step 13.</li> </ul>
5	Measure the input voltage to the Connected Services Gateway.	Use a multimeter and insulating gloves. The input voltage should be 24 V. Make sure that connector X1 is connected properly on both ends. <ul style="list-style-type: none"> <li>• If the input voltage is normal, proceed with step 6.</li> <li>• If the input voltage is abnormal, <a href="#">Troubleshooting the main computer on page 424</a>.</li> </ul>  <b>Tip</b> For more details, see <i>Circuit diagram - OmniCore V250XT</i> , rev 04 or later.
6	Check that the connector X2 is well connected and the network connection properties are available.	Make sure that connector X2 is connected properly on both ends. <ul style="list-style-type: none"> <li>• If the connection is OK, proceed with step 7.</li> <li>• If there is a problem with the connection, repair the connection and go back to step 3.</li> </ul>
7	Check the indicator RF LEDs on the Connected Services Gateway.	If the RF LEDs are: <ul style="list-style-type: none"> <li>• ON, the Connected Services Gateway is connected to network and works well.</li> <li>• OFF, the Connected Services Gateway is faulty or the connection of the connector X3 is not ok. Proceed with step 8.</li> </ul>
8	Check that the connector X3 is well connected.	Make sure that connector X3 is connected properly on both ends. <ul style="list-style-type: none"> <li>• If the connection is OK, proceed with step 9.</li> <li>• If there is a problem with the connection, repair the connection and go back to step 7.</li> </ul>
9	Check that the right type of the antenna is connected properly.  <b>Tip</b> Try moving the antenna to different locations if the RF signal level is low.	<ul style="list-style-type: none"> <li>• If the antenna is not working, repair the connection or move the antenna to a location with better RF signal.</li> <li>• If the antenna is ok, proceed with step 13.</li> </ul>
10	On the FlexPendant, check the connection log in <b>Backup and Restore</b> .	Verify that the configuration is done correctly. Verify that the mobile operator is detected (for 3G).

Continues on next page

## 7 Troubleshooting

### 7.3.8 Troubleshooting the 3G Connected Services gateway

*Continued*

	Action	Note
11	<p>For 3G, use a cell phone to test that the sim card is working. For WiFi, use a cell phone to verify the WiFi access.</p> <p> <b>Note</b></p> <p>When testing with a cell phone, use the same configuration on the cell phone.</p>	<p>See the Connected Services Gateway configuration in <i>Operating manual - Integrator's guide OmniCore</i>.</p>
12	<p>For 3G and WiFi, check the antenna connectivity.</p>	
13	<p>The Connected Services Gateway may be faulty, replace it and verify that the problem is resolved.</p>	<p>How to replace the unit is described in <a href="#">Replacing the 3G Connected Services gateway on page 214</a>.</p>

#### Related information

All documents can be found via myABB Business Portal, [www.abb.com/myABB](http://www.abb.com/myABB).

The approval code CMIIT ID is displayed on the nameplate of the product.

### 7.3.9 Troubleshooting the 4G Connected Services gateway

#### Location

The illustration shows the location of the Connected Services gateway in the controller.

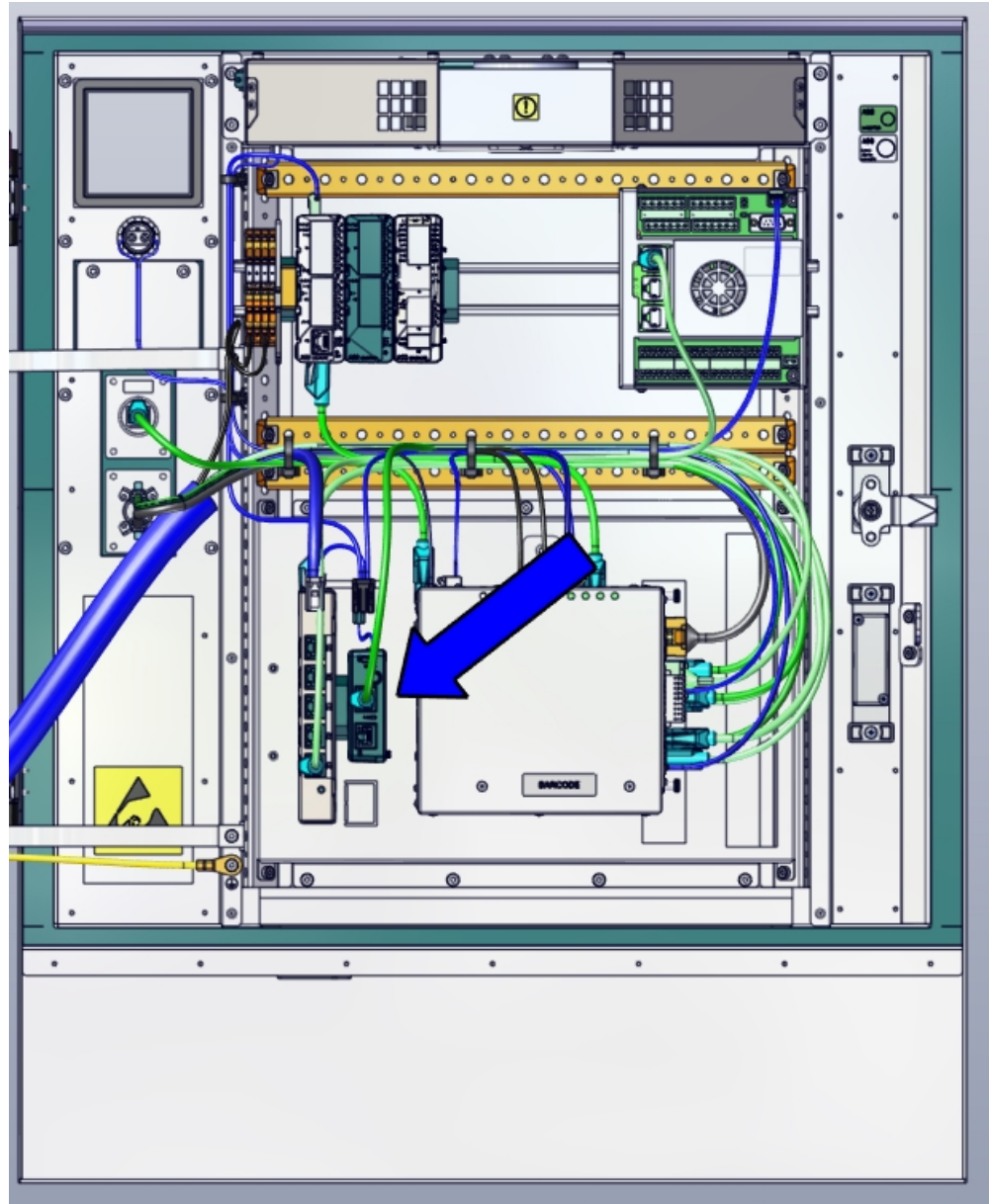

xx2300001806

*Continues on next page*

## 7 Troubleshooting

### 7.3.9 Troubleshooting the 4G Connected Services gateway

*Continued*

#### LEDs and buttons on the 4G Connected Services gateway

The illustration below shows the LEDs and the buttons on the 4G Connected Services gateway.

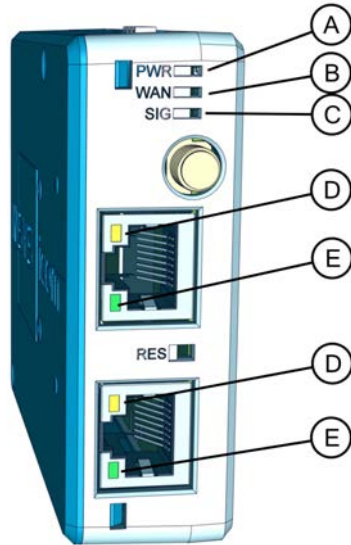

xx2300000756

A	PWR LED
B	WAN LED
C	SIG LED
D	ETH yellow LED
E	ETH green LED

#### LED description

LED	Colour	Function	off	blinking	on
PWR	green	Supply	not available		present
WAN	green	WAN chain	inactive	establishing	established
SIG	green	Signal	no signal or logged out	logged in (field strength, see table below)	
ETH	green	Link/activity	not connected	data traffic	connected
	yellow	data rate	10 Mbit/s		100 Mbit/s

Blinking interval LED SIG	Signal quality
900 ms on, 100 ms off	Very good
200 ms on, 200 ms off	Good
100 ms on, 900 ms off	Poor
off	No signal or logged out

*Continues on next page*



Required test equipment

Equipment needed for troubleshooting:

Equipment	Note
Multimeter	
Insulating gloves	

Preparations

	Action
1	Check the FlexPendant for errors and warnings.
2	Power the controller off. Wait one minute, power the controller on.
3	Wait 30-60 seconds after power-on. Make sure that the control system power is in run-time mode.

Troubleshooting flowchart for 4G Connected Services gateway

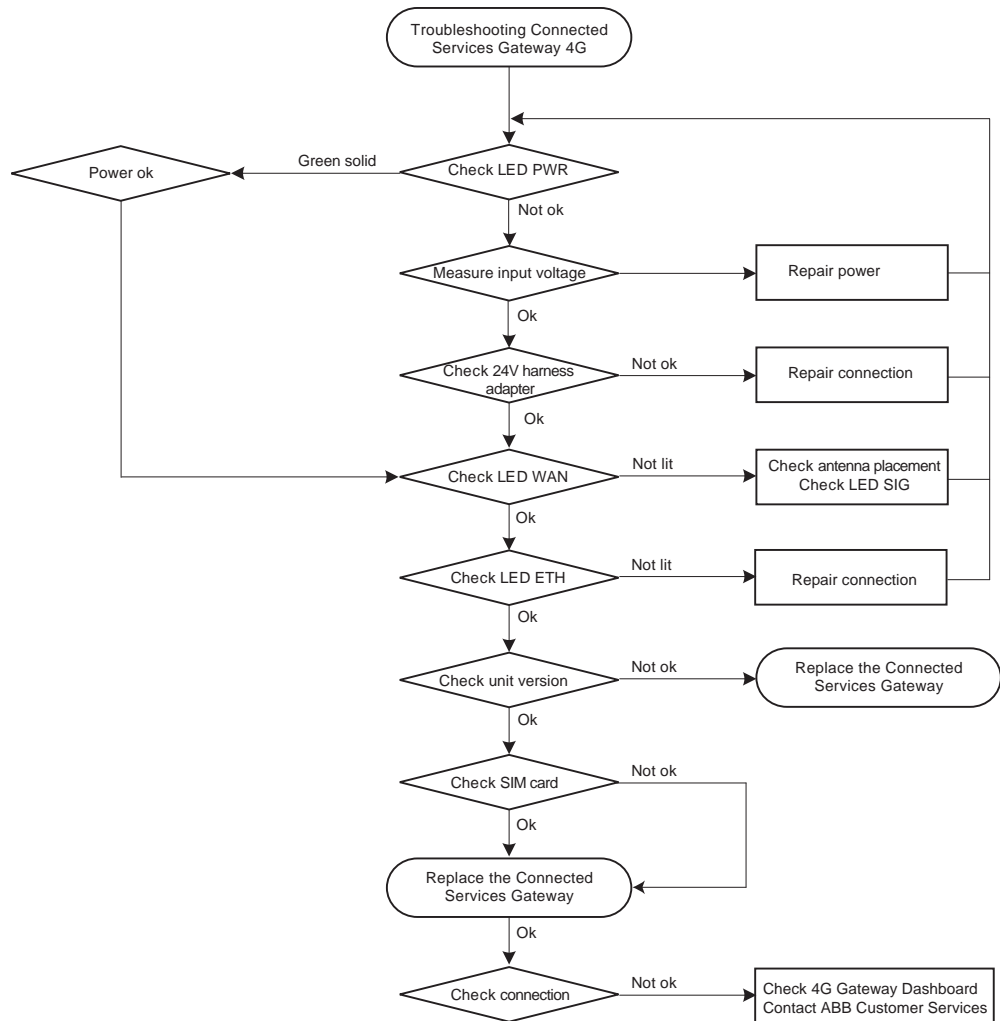

xx2300000759

Continues on next page

## 7 Troubleshooting

### 7.3.9 Troubleshooting the 4G Connected Services gateway

*Continued*

#### Troubleshooting procedures for 4G Connected Services gateway

Troubleshooting the 4G gateway can be made either by looking at the LEDs, or by connecting a PC to get status information.



#### Note

If the 4G gateway is faulty, a warranty order should be initiated. Follow the standard procedure.



#### Note

Never open the gateway. Never remove the warranty stickers. The warranty would be void. Return with ABB SIM card pre-installed.



#### CAUTION

The ABB 4G gateway has been preconfigured in factory. Resetting the gateway will make it unusable and warranty is lost. Contact ABB if reset is required.



#### Troubleshooting procedures

The troubleshooting table is supposed to be used as a detailed instruction together with the troubleshooting flowchart.

	Action	Note
1	Check the PWR LED on the Connected Services gateway.	If the LED is: <ul style="list-style-type: none"><li>• Green solid: proceed with step 4.</li><li>• OFF, proceed with step 2.</li></ul>
2	Measure the input voltage to the Connected Services Gateway.	Use a multimeter and insulating gloves. The input voltage should be 24 V. <ul style="list-style-type: none"><li>• If the input voltage is normal, proceed with step 3.</li><li>• If the input voltage is abnormal, repair power.</li></ul>  <b>Tip</b> For more details, see <i>Circuit diagram - OmniCore V250XT</i> , rev 04 or later.

*Continues on next page*

7.3.9 Troubleshooting the 4G Connected Services gateway  
Continued

	Action	Note
3	<p>Check 24V harness adapter.</p> <p>Make sure that the wires of the 24V harness adapter are connected properly:</p> <ul style="list-style-type: none"> <li>• Wire K7-W201 to the 24V (V+) connection on the Connected Services gateway.</li> <li>• Wire K7-W202 to the 0V (V-) connection on the Connected Services gateway.</li> </ul>	<ul style="list-style-type: none"> <li>• If the harness adapter connection is ok, proceed with step 4.</li> <li>• If the harness adapter connection is not ok, repair the connection.</li> </ul> <p>If PWR LED is still OFF, verify the cables.</p> <p> <b>Note</b></p> <p>The unit is able to withstand that the polarity on 24V in case the cable connection between 0 and 24V is not correct (reversed). The unit is protected against short circuit and overload to avoid fire. However, in case of a short circuit, the unit must be replaced.</p>
4	Check the WAN LED on the Connected Services gateway.	<p>If the LED is:</p> <ul style="list-style-type: none"> <li>• Green: proceed with step 5.</li> <li>• OFF, proceed with step 6.</li> </ul>
5	Check the ETH LED on the Connected Services gateway.	<p>If the LED is:</p> <ul style="list-style-type: none"> <li>• Green: proceed with step 8.</li> <li>• OFF, repair the connection.</li> </ul>
6	<p>Check that the right type of the antenna is connected properly.</p> <p> <b>Tip</b></p> <p>Try moving the antenna to different locations if the SIG signal level is low.</p>	<ul style="list-style-type: none"> <li>• If the antenna is not working, repair the connection or move the antenna to a location with better SIG signal.</li> <li>• If the antenna is ok, proceed with step 1.</li> </ul>
7	<p>Check that the correct module version is used for this region:</p> <ul style="list-style-type: none"> <li>• Check that gateway DSQC 1093 is used in Europe.</li> <li>• Check that gateway DSQC 1093A is used in USA.</li> </ul>	<ul style="list-style-type: none"> <li>• If the correct unit version is used, proceed with step 8.</li> <li>• If the correct unit version is not used, replace with the correct unit. How to replace the unit is described in <a href="#">Replacing the 4G Connected Services gateway on page 221</a>.</li> </ul>
8	Check the sim card and tampering stickers.	<ul style="list-style-type: none"> <li>• Check sim card presence. If not ok, proceed with step 9.</li> <li>• Check the sim tampering sticker. If not ok, proceed with step 9.</li> <li>• Check the Reset tampering sticker. If not ok, proceed with step 9.</li> <li>• If the SIM card is ok, proceed with step 9.</li> </ul>
9	The Connected Services Gateway may be faulty, replace it and verify that the problem is resolved.	How to replace the unit is described in <a href="#">Replacing the 4G Connected Services gateway on page 221</a> .
10	Check 4G Gateway Dashboard and Contact ABB Customer Services.	See <a href="#">Troubleshooting the unit by connecting a PC on page 415</a> .

## Troubleshooting the unit by connecting a PC

- 1 Connect a PC to the port ETH 1.

Continues on next page

## 7 Troubleshooting

### 7.3.9 Troubleshooting the 4G Connected Services gateway

*Continued*

- 2 Configure the PC Address with IP 192.168.125.100/24 (Mask 255.255.255.0).
- 3 Open a browser with <https://192.168.125.85/>.
- 4 The INSYS login page is displayed:

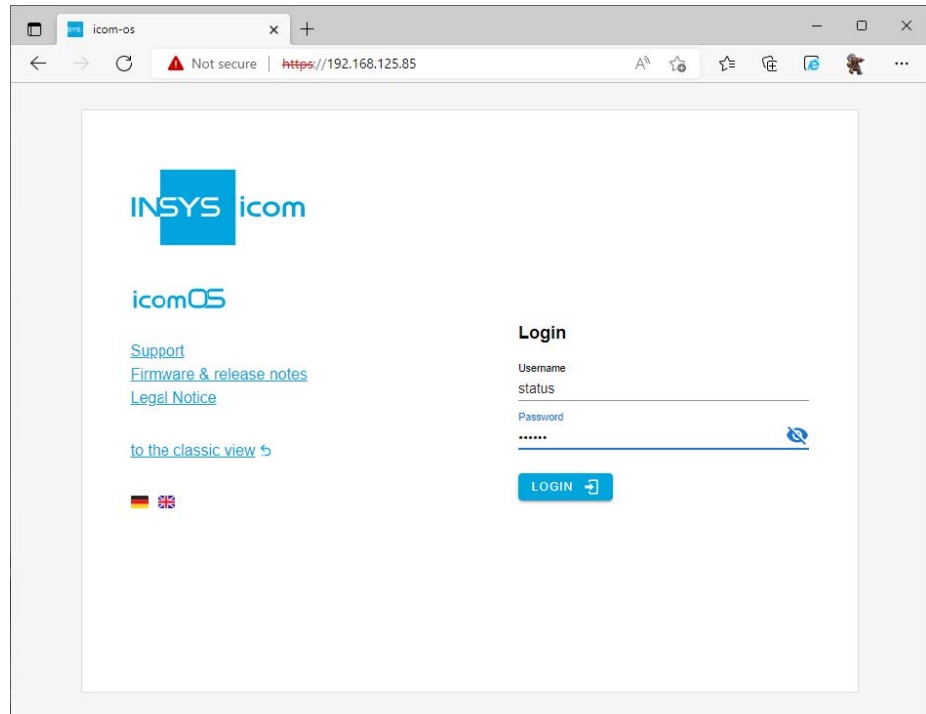

xx2300000638



#### Note

Enter the following to access this page:

**User (status)**

**Password (status)**

*Continues on next page*



**Note**

If the browser indicates that the connection is not private, click **Proceed**. This is a local connection which cannot validate the 4G gateway server certificate.



Your connection is not private

Attackers might be trying to steal your information from **192.168.125.85** (for example, passwords, messages, or credit cards). [Learn more](#)

NET:ERR\_CERT\_AUTHORITY\_INVALID

Hide advanced
Back to safety

This server could not prove that it is **192.168.125.85**; its security certificate is not trusted by your computer's operating system. This may be caused by a misconfiguration or an attacker intercepting your connection.

[Proceed to 192.168.125.85 \(unsafe\)](#)

xx2300000909

- 5 The following menus can be accessed from which further troubleshooting can be made:

Menu	Description	Further information
<b>Dashboard</b>	The status dashboard displays detailed information about the device.	<a href="#">Checking the gateway status on page 418</a> <a href="#">Checking the profile version on page 420</a> <a href="#">Checking the firmware version and serial number on page 421</a>
<b>Log view</b>	The log view displays all current logs.	<a href="#">Troubleshoot the unit using the log page on page 418</a>
<b>Log download</b>	Download a package with all logs, archives and current status. The logs can be saved as a file and be sent to ABB L3/L4 Support for analysis.	<a href="#">Troubleshoot the unit using the log page on page 418</a>
<b>Support Packet</b>	Download a support packet that includes the status of the running router and the complete configuration. The support packet can be saved as a file and be sent to ABB L3/L4 Support for analysis.	<a href="#">Troubleshoot the unit using the log page on page 418</a>

*Continues on next page*

## 7 Troubleshooting

### 7.3.9 Troubleshooting the 4G Connected Services gateway

Continued

Troubleshoot the unit using the log page

- 1 Connect a PC. See [Troubleshooting the unit by connecting a PC on page 415](#).
- 2 Connect to the **Log** pages of the 4G gateway.
- 3 The **Log view** displays all current logs:

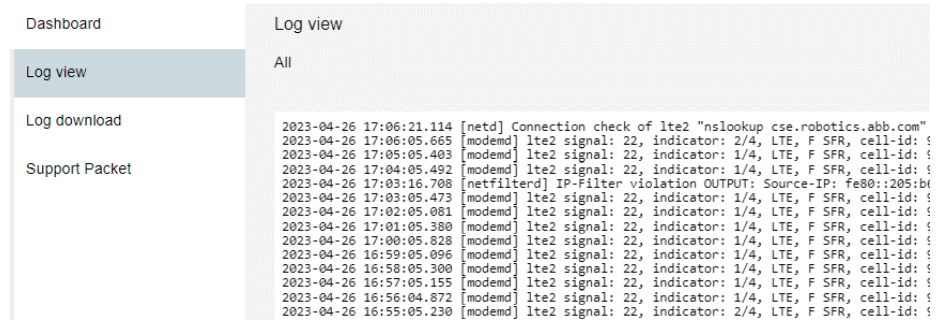

The screenshot shows a web interface with a sidebar on the left containing 'Dashboard', 'Log view', 'Log download', and 'Support Packet'. The 'Log view' page is active, displaying a list of logs under the heading 'All'. The logs are timestamped and include details such as signal strength, indicator, and LTE status. The first few lines of the log are:

```
2023-04-26 17:06:21.114 [netd] Connection check of lte2 "nslookup cse.robotics.abb.com"
2023-04-26 17:06:05.665 [modemd] lte2 signal: 22, indicator: 2/4, LTE, F SFR, cell-id: 5
2023-04-26 17:05:05.403 [modemd] lte2 signal: 22, indicator: 1/4, LTE, F SFR, cell-id: 5
2023-04-26 17:04:05.492 [modemd] lte2 signal: 22, indicator: 1/4, LTE, F SFR, cell-id: 5
2023-04-26 17:03:16.708 [netfilterd] IP-Filter violation OUTPUT: Source-IP: fe80::205:bd
2023-04-26 17:03:05.473 [modemd] lte2 signal: 22, indicator: 1/4, LTE, F SFR, cell-id: 5
2023-04-26 17:02:05.081 [modemd] lte2 signal: 22, indicator: 1/4, LTE, F SFR, cell-id: 5
2023-04-26 17:01:05.380 [modemd] lte2 signal: 22, indicator: 1/4, LTE, F SFR, cell-id: 5
2023-04-26 17:00:05.828 [modemd] lte2 signal: 22, indicator: 1/4, LTE, F SFR, cell-id: 5
2023-04-26 16:59:05.096 [modemd] lte2 signal: 22, indicator: 1/4, LTE, F SFR, cell-id: 5
2023-04-26 16:58:05.300 [modemd] lte2 signal: 22, indicator: 1/4, LTE, F SFR, cell-id: 5
2023-04-26 16:57:05.155 [modemd] lte2 signal: 22, indicator: 1/4, LTE, F SFR, cell-id: 5
2023-04-26 16:56:04.872 [modemd] lte2 signal: 22, indicator: 1/4, LTE, F SFR, cell-id: 5
2023-04-26 16:55:05.230 [modemd] lte2 signal: 22, indicator: 2/4, LTE, F SFR, cell-id: 5
```

xx2300000911

- 4 The **Log download** and **Support Packet** pages allow saving logs for ABB troubleshooting. These logs can be saved as a file and be sent to ABB L3/L4 Support for analysis.

- **Log download:**

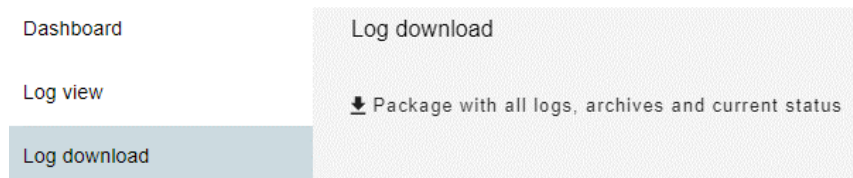

The screenshot shows the 'Log download' page with a sidebar on the left containing 'Dashboard', 'Log view', and 'Log download'. The 'Log download' page is active, displaying a button with a download icon and the text 'Package with all logs, archives and current status'.

xx2300000912

- **Support Packet:**



The screenshot shows the 'Support Packet' page with a sidebar on the left containing 'Dashboard', 'Log view', 'Log download', and 'Support Packet'. The 'Support Packet' page is active, displaying a button with the text 'CREATE SUPPORT PACKET' and a download icon. Below the button, there is a section for 'File name' and 'Downloadable', showing the file name 'support-2023-04-13\_16\_14\_36.bin' and a download icon.

xx2300000913

Checking the gateway status

- 1 Connect a PC. See [Troubleshooting the unit by connecting a PC on page 415](#).

Continues on next page

### 2 Connect to the Dashboard of the 4G gateway.



xx230000639

### 3 On the Dashboard, verify the following:

- Verify that the WAN chain is online.

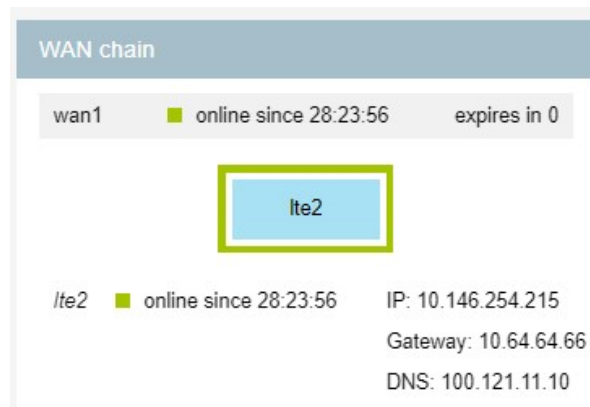

xx230000640

*Continues on next page*

## 7 Troubleshooting

### 7.3.9 Troubleshooting the 4G Connected Services gateway

Continued

- Verify that LTE2 is online and registered.

LTE2	
status	Online
Provider	F SFR (20810)
Network used	LTE, (band 7)
Signal indicator	 1/4
Network registration state	Registered and roaming
Cell-ID	96CEE02
Location-ID	BB85
ICCID/USIM	89011703278751394084
IMEI	865583041848853

xx2300000910

- Network registration state is registered

Checking the profile version

- 1 Connect a PC. See [Troubleshooting the unit by connecting a PC on page 415](#).
- 2 Connect to the **Dashboard** of the 4G gateway.
- 3 On the **Dashboard**, the field **Hash of running profile** displays the profile version.

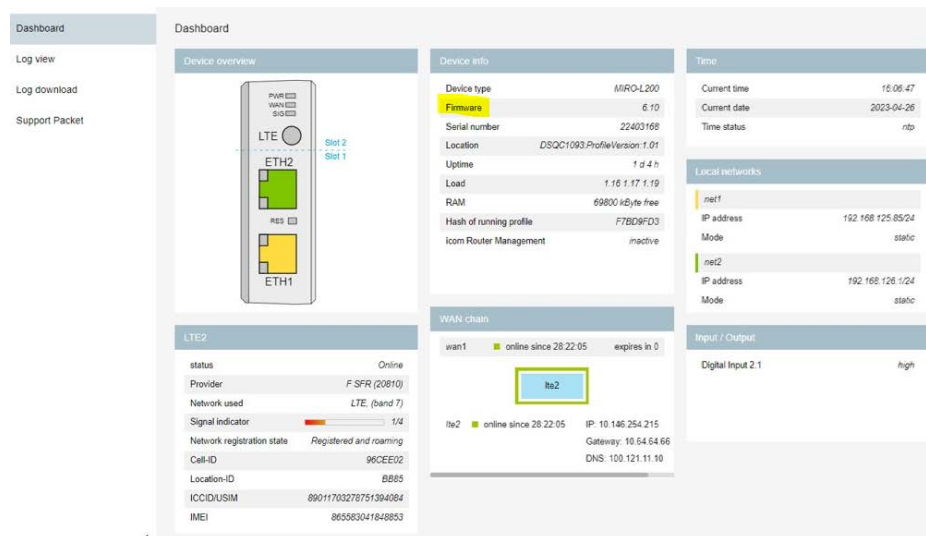

The screenshot shows the dashboard of a 4G gateway. The 'Device overview' section displays a diagram of the device with LTE2, ETH2, ETH1, and RES ports. The 'Device info' section shows details such as Device type (MIRO-L200), Firmware (6.10), Serial number (22403168), Location (DSQC1093.ProfileVersion:1.01), Uptime (1 d 4 h), Load (1.16 1.17 1.19), RAM (69800 kByte free), Hash of running profile (F7BD9FD3), and Icom Router Management (inactive). The 'WAN chain' section shows wan1 (online since 28.22.05, expires in 0) and ita2 (online since 28.22.05, IP: 10.146.254.215, Gateway: 10.54.54.66, DNS: 100.121.11.10). The 'Local networks' section shows net1 and net2 with IP addresses and static modes. The 'Input / Output' section shows Digital Input 2.1 (high). The 'Time' section shows Current time (15:06:47), Current date (2023-04-26), and Time status (ntp).

xx2300000763

It is recommended to store the profile version for reference. This can be used later to verify that the unit has not been reset or tampered with.



#### CAUTION

Contact ABB if the profile version has changed or if the box has been reset.

Continues on next page



7.3.9 Troubleshooting the 4G Connected Services gateway  
Continued

## Checking the firmware version and serial number

- 1 Connect a PC. See [Troubleshooting the unit by connecting a PC on page 415](#).
- 2 Connect to the **Dashboard** of the 4G gateway.
- 3 On the **Dashboard**, the field **Firmware** displays the firmware version. The minimal firmware required is FW 6.11.

The screenshot shows the dashboard of a 4G gateway. The 'Device overview' section displays a physical device with ports labeled PWR, WAN, SDCB, LTE, ETH2, RES, and ETH1. The 'Device info' section provides the following details:

Device type	MRO-L200
Firmware	6.10
Serial number	2240168
Location	DSQC1993 Profile/Version 1.01
Uptime	1 d 4 h
Load	1.16 1.17 1.19
RAM	69800 kByte free
Hash of running profile	F7B09FD3
Icom Router Management	inactive

The 'WAN chain' section shows the status of WAN ports:

wan1	online since 28:22:05	expires in 0
lte2	online since 28:22:05	IP: 10.146.254.215 Gateway: 10.64.64.66 DNS: 100.121.11.10

The 'Local networks' section lists two networks:

net1	IP address: 192.168.125.85/24 Mode: static
net2	IP address: 192.168.126.1/24 Mode: static

The 'Input / Output' section shows Digital Input 2.1 is high.

xx2300000763

## Related information

All documents can be found via myABB Business Portal, [www.abb.com/myABB](http://www.abb.com/myABB).

## 7 Troubleshooting

### 7.3.10 Troubleshooting the Ethernet switch (DSQC1035)

#### 7.3.10 Troubleshooting the Ethernet switch (DSQC1035)

##### Location

The illustration shows the location of the Ethernet switch in the controller.

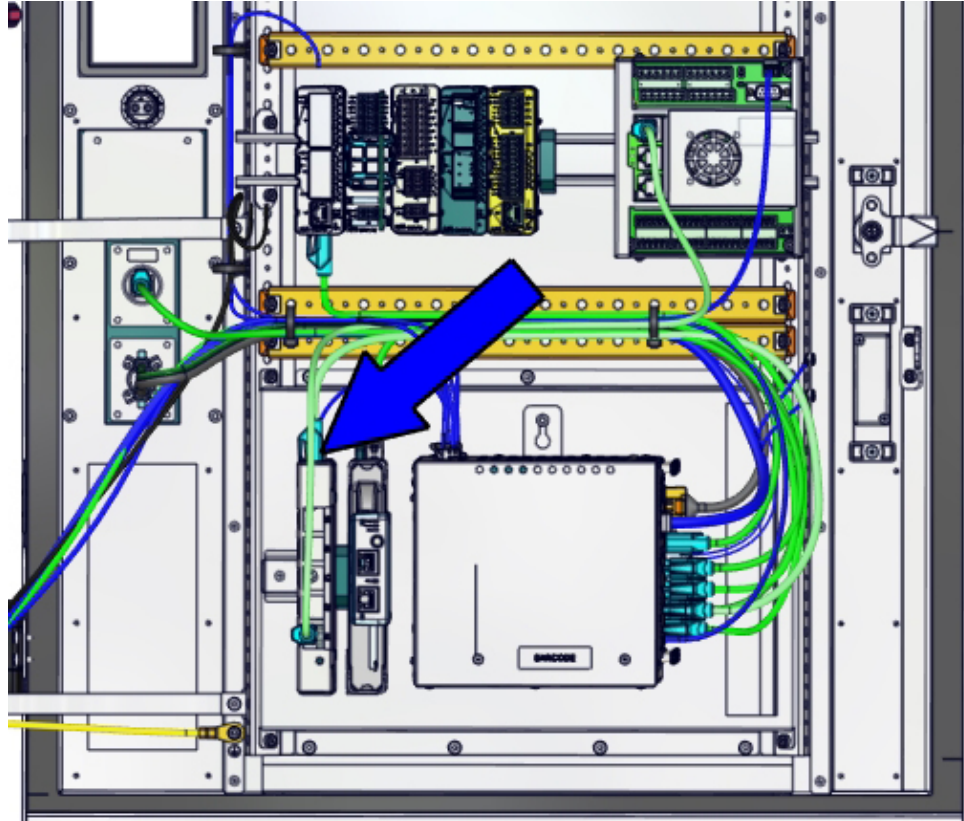

xx2300001820

*Continues on next page*

## LEDs

The illustration below shows the indication LEDs on the Ethernet switch.

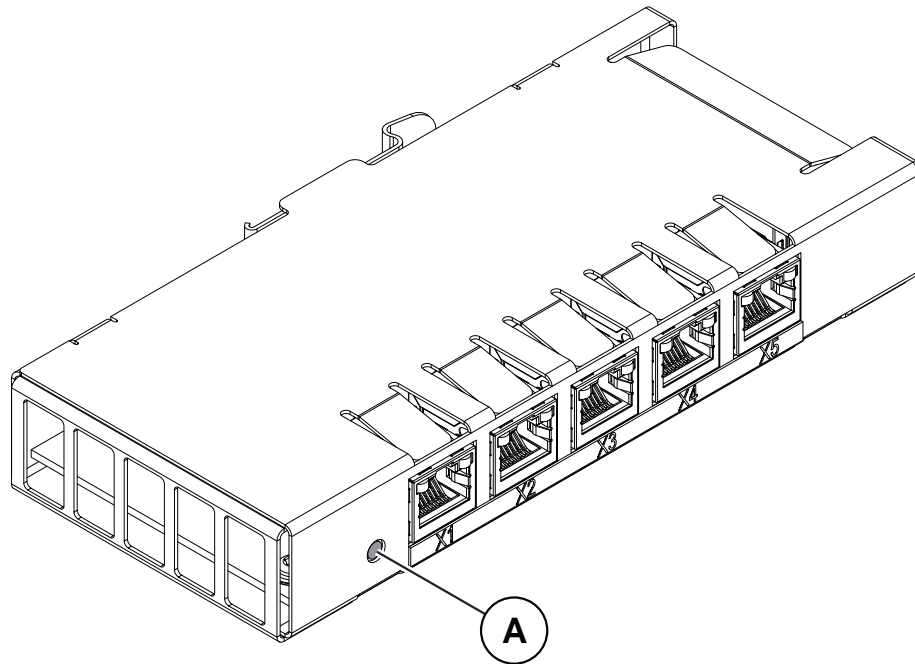

xx180000584

A	Status LED
Description	Significance
Status LED	<p>Startup sequence:</p> <ol style="list-style-type: none"> <li>1 No color: Input voltage is outside specified voltage or internal fault in the switch.</li> <li>2 Green, solid: The switch is operational.</li> </ol> <p>If the LED does not turn steady green, the status indicator LED can be used to identify the following issues:</p> <p>Fault indication:</p> <ul style="list-style-type: none"> <li>• No color: If input voltage is within specified voltage limits and the LED is not lit then replace the switch.</li> </ul>
Ethernet LEDs	<p>Shows the status of Ethernet links.</p> <p>Green:</p> <ul style="list-style-type: none"> <li>• Off: 10 Mbps data rate is selected.</li> <li>• On: 100/1000 Mbps data rate is selected.</li> </ul> <p>Yellow:</p> <ul style="list-style-type: none"> <li>• Flashing: The Ethernet is active on link.</li> <li>• Solid: A LAN link is established.</li> <li>• Off: A LAN link is <i>not</i> established.</li> </ul>

## 7 Troubleshooting

### 7.3.11 Troubleshooting the main computer

#### 7.3.11 Troubleshooting the main computer

##### Location

The illustration shows the location of the main computer in the controller.

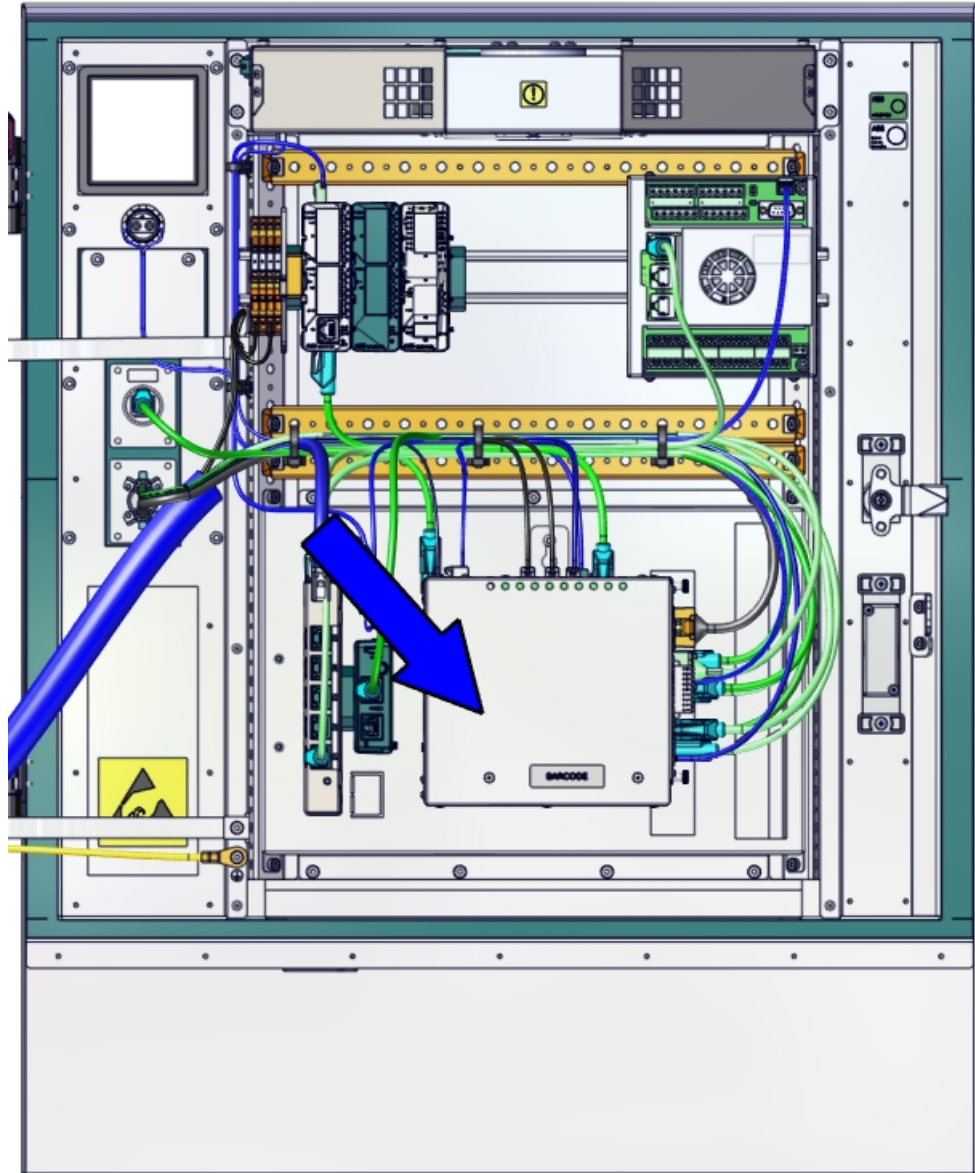

xx2300001837

*Continues on next page*

#### LEDs

The following sections display the LEDs on the main computer units.

#### Power distribution board, DSQC1085

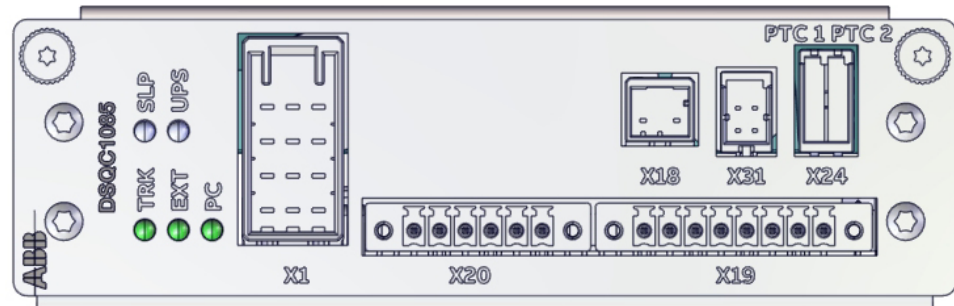

xx230000434

Name	Description
TRK LED	Shows the TRUNK input status: <ul style="list-style-type: none"> <li>Green: 24V TRUNK input voltage (X1) &gt; 21V</li> </ul>
SLP LED	Shows the sleep status: <ul style="list-style-type: none"> <li>Green: Unit placed in sleep state (Low power mode)</li> </ul>
EXT LED	Shows the external 24V input status: <ul style="list-style-type: none"> <li>Green: 24V External 24V input (X20) &gt; 21V</li> </ul>
UPS LED	Shows the charge status: <ul style="list-style-type: none"> <li>Green: Capacitors are fully charged.</li> <li>Red: Capacitors are not fully charged/discharged. Warning sign to not unplug PDB.</li> <li>Off: Capacitors empty. Safe to unplug PDB.</li> </ul>
PC LED	Shows the 5V_PC status: <ul style="list-style-type: none"> <li>Green (steady): 5V_PC is available.</li> </ul>

#### Processor board, DSQC1086

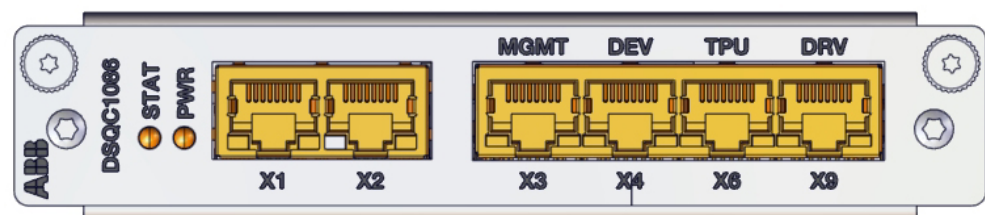

xx230000440

*Continues on next page*

## 7 Troubleshooting

### 7.3.11 Troubleshooting the main computer

Continued

Name	Description
STAT Status (Red/Green)	Shows the unit status: <ul style="list-style-type: none"> <li>Red (steady): Default when power is available</li> <li>Red (flashing ~1Hz): Power on self-test ongoing / OS loading</li> <li>Green (flashing ~1Hz): Base Application loading and initializing</li> <li>Green (uneven flashing ~1Hz): Installation Utility Application loaded and ready for recovery operation</li> <li>Green (steady): Application is ready and unit is operational</li> </ul>
PWR Power (Red/Green)	Shows the Signal exchange proxy status: <ul style="list-style-type: none"> <li>Red (steady): Default when power is available</li> <li>Green (flashing ~1Hz): Application loaded and waiting for communication with Base Application</li> <li>Green (steady): Signal exchange proxy is operational</li> </ul> If the LED does not turn steady green after 30-60 sec, the PWR LED can be used to identify the following issues: <ul style="list-style-type: none"> <li>No color: Power to module is missing</li> <li>Red (steady): Internal Error</li> <li>Green (pulsing ~1Hz): Communication error to Base Application</li> </ul> <div style="display: flex; align-items: center; margin-top: 10px;">  <p><b>Note</b></p> </div> <p>PWR LED will continue flashing until STAT LED is solid green.</p>

Ethernet switch, DSQC1088

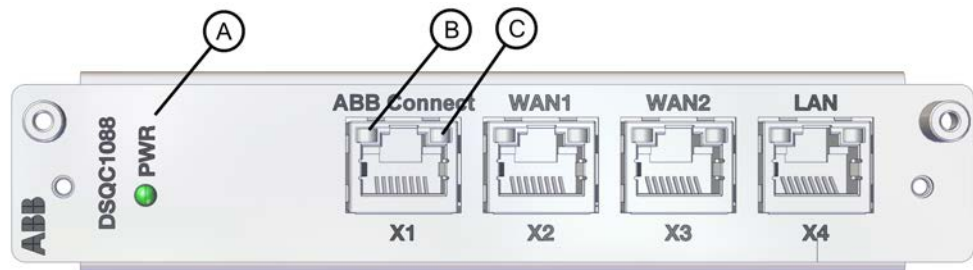

xx230000968

	Name	Description
A	PWR (Power) LED	Shows the Ethernet switch board status: <ul style="list-style-type: none"> <li>Off: All Ethernet ports in Power Off state.</li> <li>Green: Ethernet ports are configured and enabled.</li> </ul>
B	Link/activity LED (Yellow):	<ul style="list-style-type: none"> <li>Flashing: The Ethernet is active on link.</li> <li>Solid: A LAN link is established.</li> <li>Off: A LAN link is <i>not</i> established.</li> </ul>
C	Speed LED (Green):	<ul style="list-style-type: none"> <li>Off: 10 Mbps data rate is selected.</li> <li>On: 100/1000 Mbps data rate is selected.</li> </ul>

Continues on next page

#### Safety board, DSQC1087



xx230000501

Name	Description	
HMI	FlexPendant power output LED (green)	FlexPendant power output LED can be used to identify the following status: <ul style="list-style-type: none"> <li>No color: FlexPendant power output voltage is not in normal range.</li> <li>Green, solid: FlexPendant power output voltage is in normal range.</li> </ul>
MON	Motors_ON LED (white)	Motors_ON LED can be used to identify the following status: <ul style="list-style-type: none"> <li>No color: Motors_ON function is off.</li> <li>White, solid: Motors_ON function is on.</li> <li>White, flashing: safety loop is open, for example after an emergency stop.</li> </ul>
AS1 & AS2	Automatic Stop LEDs (green) AS1 : Automatic Stop LED channel 1 AS2 : Automatic Stop LED channel 2	Automatic Stop LED can be used to identify the following status: <ul style="list-style-type: none"> <li>No color (not lit): Automatic Stop input loop is open.</li> <li>Green, solid: Automatic Stop input loop is closed.</li> </ul>
GS1 & GS2	General Stop LEDs (green) GS1 : General Stop LED channel 1 GS2 : General Stop LED channel 2	General Stop LED can be used to identify the following status: <ul style="list-style-type: none"> <li>No color (not lit): General Stop input loop is open.</li> <li>Green, solid: General Stop input loop is closed.</li> </ul>
ESO1 & ESO2	Emergency stop output LEDs (green) ESO1 : Emergency stop output LED channel 1 ESO2 : Emergency stop output LED channel 2	Emergency stop output LED can be used to identify the following status: <ul style="list-style-type: none"> <li>No color (not lit): Emergency stop output is in State 0 (0V) status.</li> <li>Green, solid: Emergency stop output is in State 1 (24V) status.</li> </ul>
ES1 & ES2	External emergency stop LEDs (green) ES1 : External emergency stop LED channel 1 ES2 : External emergency stop LED channel 2	External emergency stop LED can be used to identify the following status: <ul style="list-style-type: none"> <li>No color (not lit): External emergency stop input loop is open.</li> <li>Green, solid: External emergency stop input loop is closed.</li> </ul>

*Continues on next page*



## 7 Troubleshooting

### 7.3.11 Troubleshooting the main computer

Continued

#### Troubleshooting procedure

	Action	Note
1	Make sure the power has been off for more than 10 seconds. Power on the controller.	Wait at least 1 min after power-on.
2	Check LED TRK on Power distribution board, DSQC1085.	<ul style="list-style-type: none"> <li>If LED TRK is green, proceed with <a href="#">3</a>.</li> <li>If LED TRK is not green, proceed with <a href="#">6</a>.</li> </ul>
3	Check LEDs PC (Power distribution board, DSQC1085) and HMI (Safety board, DSQC1087).	<ul style="list-style-type: none"> <li>LED PC and LED HMI are green, proceed with <a href="#">4</a>.</li> <li>LED PC and LED HMI are not green, proceed with <a href="#">13</a>.</li> </ul>
4	Check the STAT LED on the processor board (DQSC1086).	If the STAT LED is: <ul style="list-style-type: none"> <li>Green, steady: Application is ready and unit is operational. Proceed with step <a href="#">5</a>.</li> <li>Green (uneven flashing ~1Hz): Installation Utility Application loaded and ready for recovery operation. Proceed with step <a href="#">5</a>.</li> <li>Off or red flashing: The unit is faulty and needs to be replaced. Proceed with step <a href="#">13</a>.</li> </ul>
5	Check LED PWR on Processor board, DSQC1086.	If the PWR LED is: <ul style="list-style-type: none"> <li>Green, steady: Unit is operational. Proceed with step <a href="#">9</a>.</li> <li>Green (pulsing ~1Hz): Communication error to PS-side application. Proceed with step <a href="#">12</a>.</li> <li>Off or red: Proceed with step <a href="#">13</a>.</li> </ul>
6	Measure the 24V_TRUNK at connector A2.K1.X1.	Verify that the input to A2.K1.X1 is 25.2 VDC +/- 5%. <ul style="list-style-type: none"> <li>If the measured voltage is normal, proceed with step <a href="#">13</a>.</li> <li>If the measured voltage is abnormal, proceed with step <a href="#">7</a>.</li> </ul>
7	Make sure that the cables are connected properly at 24V_TRUNK (A2.K1.X1).	If the connection and cables seem OK, proceed with step <a href="#">8</a> .
8	Measure the 24VDC_TRUNK at connector A1.X6.	Verify that the input to A1.X6 is 25.2 VDC +/- 5%. <ul style="list-style-type: none"> <li>If the measured voltage is normal, proceed with step <a href="#">9</a>.</li> <li>If the measured voltage is abnormal, troubleshoot the power unit. See <a href="#">Troubleshooting the power unit on page 391</a>.</li> </ul>
9	Check the UPS LED on the power distribution board (DSQC1085).	If the UPS LED is: <ul style="list-style-type: none"> <li>Steady green: Proceed with step <a href="#">11</a>.</li> <li>Off: Proceed with step <a href="#">10</a>.</li> </ul>
10	Check error message on FlexPendant and take appropriate action.	<ul style="list-style-type: none"> <li>If the error message is insufficient, proceed with step <a href="#">11</a>.</li> <li>If an error was resolved, restart from step <a href="#">4</a>.</li> </ul>

Continues on next page



	Action	Note
11	Force start the RobotWare Installation Utilities mode, see <a href="#">Controller fails to start on page 371</a> .	
12	Install/re-install RobotWare, if possible.	
13	The main computer may be faulty, replace it and verify that the fault has been fixed.	See <a href="#">Replacing the main computer on page 238</a> .

## 7 Troubleshooting

### 7.3.12 Troubleshooting the process power supply

#### 7.3.12 Troubleshooting the process power supply

##### Location

The process power supply, DSQC 609, is located as shown in the figure below.



##### CAUTION

If there are two or more power supply units mounted in a row and too close to each other, there will be a heating problem and the units can be damaged.

To avoid damaging the power supply units, the units must be separated with 3 pcs of exterior support.

##### LEDs

The illustration below shows the LEDs on the process power supply module:

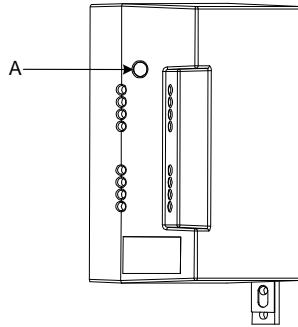

en1000000037

Description	Significance
DC OK	GREEN: When all DC outputs are within the specified output voltage levels. OFF: When DC output voltage is outside the specified voltage levels or turned off due to short circuit or overload.

### 7.3.13 Troubleshooting the power supply, ODVA

#### Location

The ODVA power supply, DSQC 634, is located as shown in the figure below.

#### LEDs

The illustration below shows the LEDs on the ODVA power supply module:

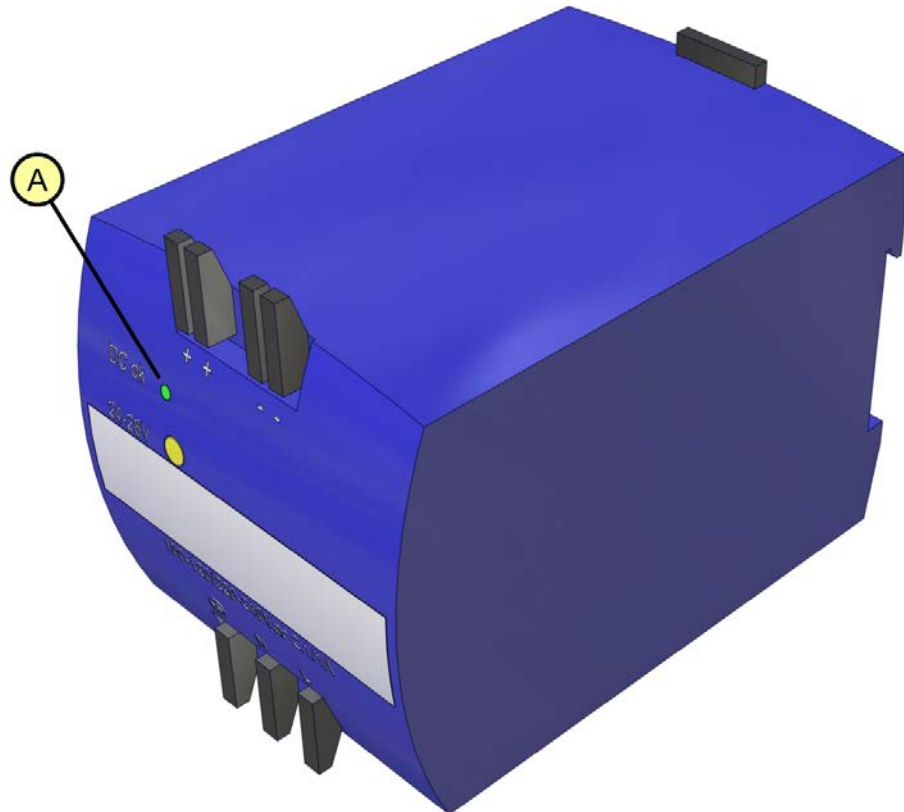

xx2100001077

Description	Significance
DC OK	<p>GREEN: When all DC outputs are within the specified output voltage levels.</p> <p>OFF: When DC output voltage is outside the specified voltage levels or turned off due to short circuit or overload.</p>

**This page is intentionally left blank**

# 8 Reference information

## 8.1 Introduction

---

### General

This chapter includes general information, complementing the more specific information in the different procedures in the manual.

## 8 Reference information

---

### 8.2 Applicable standards

### 8.2 Applicable standards

---

#### General

The product is compliant with ISO 10218-1:2011, *Robots for industrial environments - Safety requirements - Part 1 Robots*, and applicable parts in the normative references, as referred to from ISO 10218-1:2011. In case of deviation from ISO 10218-1:2011, these are listed in the declaration of incorporation. The declaration of incorporation is part of the delivery.

---

#### Robot standards

Standard	Description
ISO 9283	Manipulating industrial robots – Performance criteria and related test methods
ISO 9787	Robots and robotic devices – Coordinate systems and motion nomenclatures
ISO 9946	Manipulating industrial robots – Presentation of characteristics

---

#### Other standards used in design

Standard	Description
IEC 60204-1	Safety of machinery - Electrical equipment of machines - Part 1: General requirements, normative reference from ISO 10218-1
IEC 61000-6-2	Electromagnetic compatibility (EMC) – Part 6-2: Generic standards – Immunity standard for industrial environments
IEC 61000-6-4	Electromagnetic compatibility (EMC) – Part 6-4: Generic standards – Emission standard for industrial environments
ISO 13849-1:2006	Safety of machinery - Safety related parts of control systems - Part 1: General principles for design, normative reference from ISO 10218-1

## 8.3 Unit conversion

### Converter table

Use the following table to convert units used in this manual.

Quantity	Units		
Length	1 m	3.28 ft.	39.37 in
Weight	1 kg	2.21 lb.	
Weight	1 g	0.035 ounces	
Pressure	1 bar	100 kPa	14.5 psi
Force	1 N	0.225 lbf	
Moment	1 Nm	0.738 lbf-ft	
Volume	1 L	0.264 US gal	

## 8 Reference information

---

### 8.4 Standard toolkit for controller

### 8.4 Standard toolkit for controller

---

#### General

All service (repair, maintenance and installation) instructions contain lists of tools required to perform the specified activity. All special tools, that is, all tools that are not considered as standard tools as defined below, are listed in their instructions respectively.

This way, the tools required are the sum of the standard toolkit and any tools listed in the instructions.

#### Standard toolkit for controller

Tool	Description
Screw driver, Torx	Tx10
Screw driver, Torx	Tx20
Screw driver, Torx	Tx25
Ball tipped screw driver, Torx	Tx25
Screw driver, flat blade	4 mm
Screw driver, flat blade	8 mm
Screw driver, flat blade	12 mm
Screw driver	Phillips-1
Box spanner	8 mm

#### Toolkit recommended for troubleshooting

Tool	Note
Normal shop tools	Contents as specified above.
Multimeter	-
Camera	To document problems or procedures



## 8.5 Screw joints

### General

This section details how to tighten the various types of screw joints on the controller. The instructions and torque values are valid for screw joints comprised of metallic materials and do *not* apply to soft or brittle materials.

### Tightening torque

Before tightening any screw, note the following:

- Determine whether a standard tightening torque or special torque is to be applied. The standard torques are specified in the tables below. Any special torques are specified in the Repair, Maintenance or Installation procedure description. Any special torque specified overrides the standard value.
- Use the *correct tightening torque* for each type of screw joint.
- Only use *correctly calibrated* torque keys.
- Always *tighten the joint by hand*, and never use pneumatical tools.
- Use the *correct tightening technique*, i.e. *do not* jerk. Tighten the screw in a slow, flowing motion.
- Maximum allowed total deviation from the specified value is **10%**!

The table below specifies the recommended standard tightening torque for *oil-lubricated screws with slotted or cross-recess heads*.

Dimension	Tightening torque (Nm) Class 4.8, oil-lubricated
M2.5	0.25
M3	0.5
M4	1.2
M5	2.5
M6	5.0

## 8 Reference information

---

### 8.6 Weight specifications

### 8.6 Weight specifications

---

#### Definition

In all repair and maintenance instructions, weights of the components handled are sometimes specified. All components exceeding 22 kg (50 lbs) are high-lighted in this way.

To avoid injury, ABB recommends the use of lifting equipment when handling components with a weight exceeding 22 kg.

---

#### Example

Below is an example of how a weight specification is presented:



#### **CAUTION**

The transformer weighs 55 kg! All lifting equipment used must be sized accordingly!

## 8.7 Lifting accessories and lifting instructions

---

### General

Many repair and maintenance activities require different pieces of lifting accessories, which are specified in each procedure.

The use of each piece of lifting accessories is *not* detailed in the activity procedure, but in the instruction delivered with each piece of lifting accessories.

The instructions delivered with the lifting accessories should be stored for later reference.

**This page is intentionally left blank**

---

## 9 Spare parts

---

### Spare part level

ABB spare parts are categorized into two levels, L1 and L2. Always check the part level before conducting a service work on a spare part.

- L1 spare parts

The L1 parts can be replaced in the field. The maintenance and replacement instructions given in the related product manuals must be strictly followed. If there are any problems, contact your local ABB for support.

- L2 spare parts

To replace the L2 parts require specialized training and might need special tools. Only ABB field service personnel or qualified personnel trained by ABB can replace L2 parts.

- L3 spare parts

L3 spare parts shall only be replaced or repaired by qualified ABB service technician with knowledge of the application due to risk of injury to equipment. Improper installation may void warranty.

*Continues on next page*

## 9 Spare parts

---

### 9.1 Controller parts

### 9.1 Controller parts



#### Note

Removed parts and spare parts must not be disassembled or opened.

*Continues on next page*

9.1.1 Controller system parts

Drive units

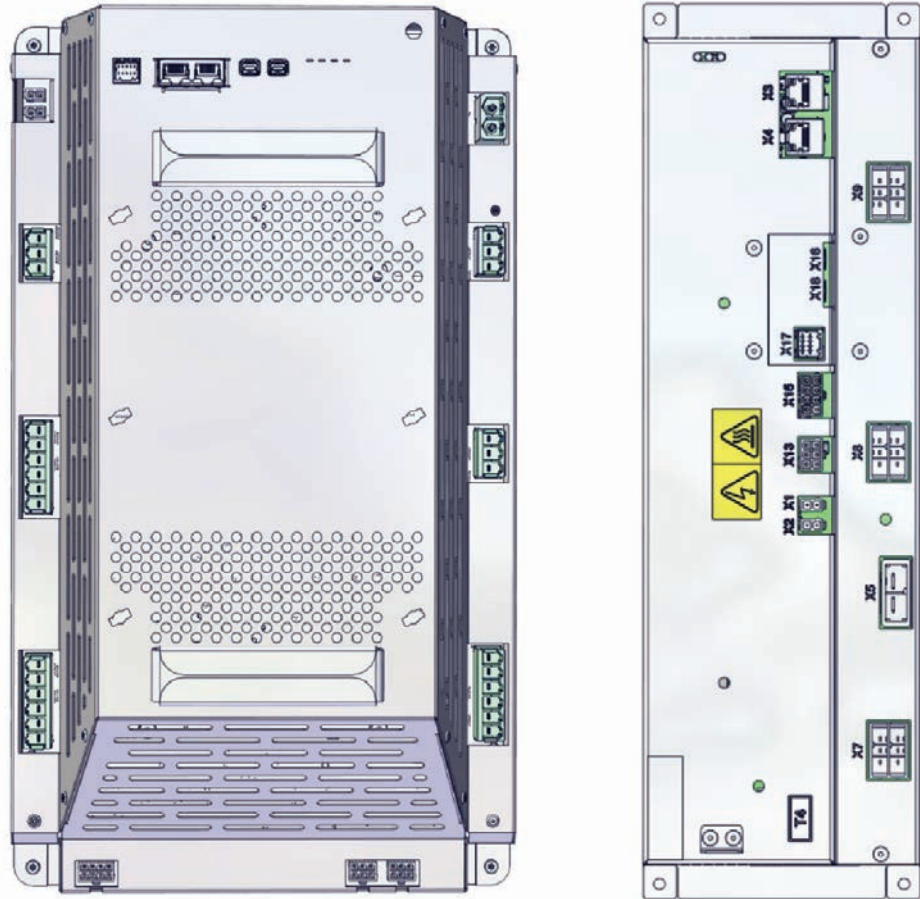

xx240000258

	Spare part number	Description	Type	Spare part level
-	3HAC064590-001	Drive unit, High Voltage	DSQC3062	L1

Continues on next page

## 9 Spare parts

### 9.1.1 Controller system parts

*Continued*

#### Additional drive units

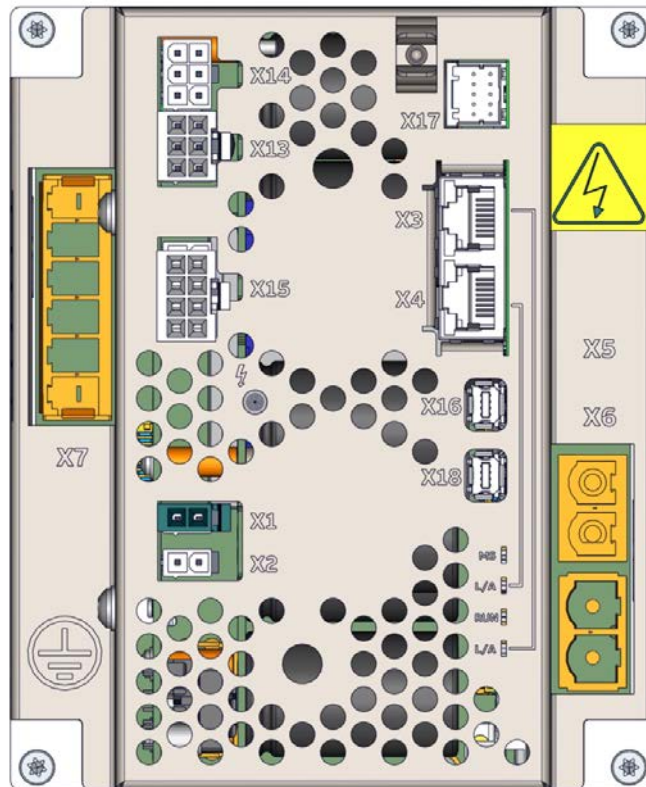

xx2200001050

	Spare part number	Description	Type	Spare part level
-	3HAC064983-001	Drive unit	DSQC 3065	L1

*Continues on next page*



#### Power units

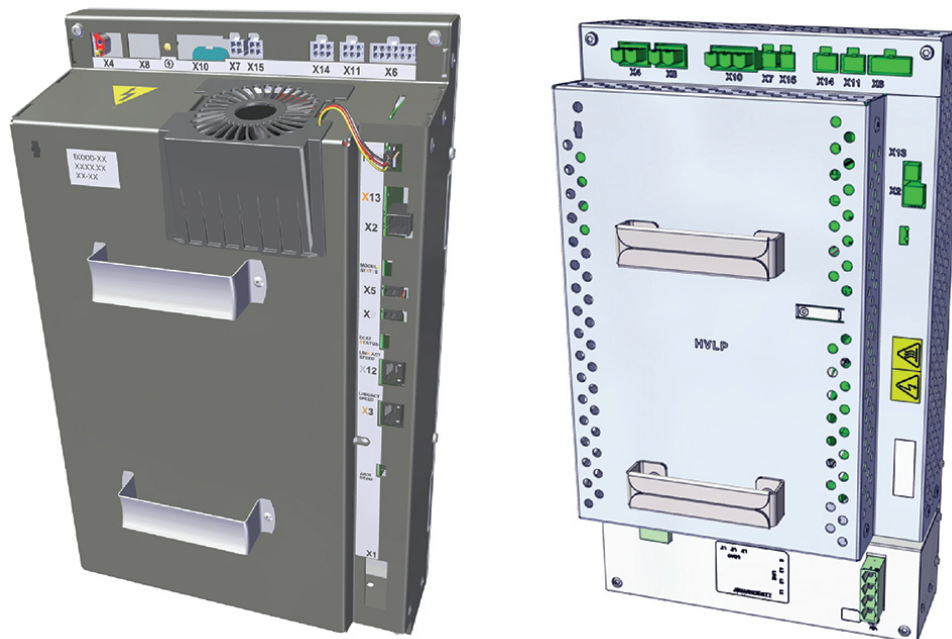

xx2300001784

	Spare part number	Description	Type	Spare part level
-	3HAC063632-001	Power unit	DSQC3070 HV 3x380-480V	L1
-	3HAC062699-001	Power unit	DSQC3069 LV 3x380-480V	L1
-	3HAC066498-001	Power unit	DSQC3072 HVLP	L1

*Continues on next page*

## 9 Spare parts

### 9.1.1 Controller system parts

*Continued*

#### Break resistor bleeder

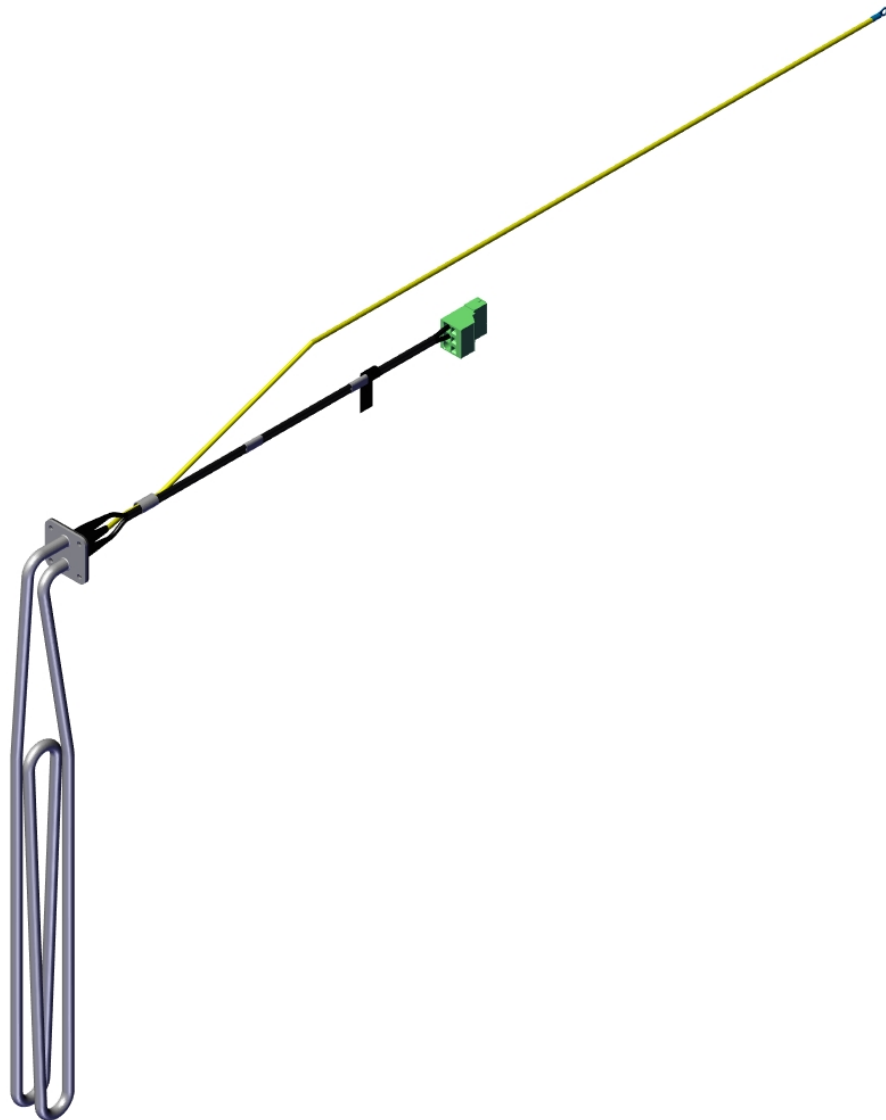

xx2200001092

	Spare part number	Description	Type	Spare part level
A	3HAC081951-001	Break resistor bleeder assembly		L1

*Continues on next page*

**Harness ETH outlet connection**

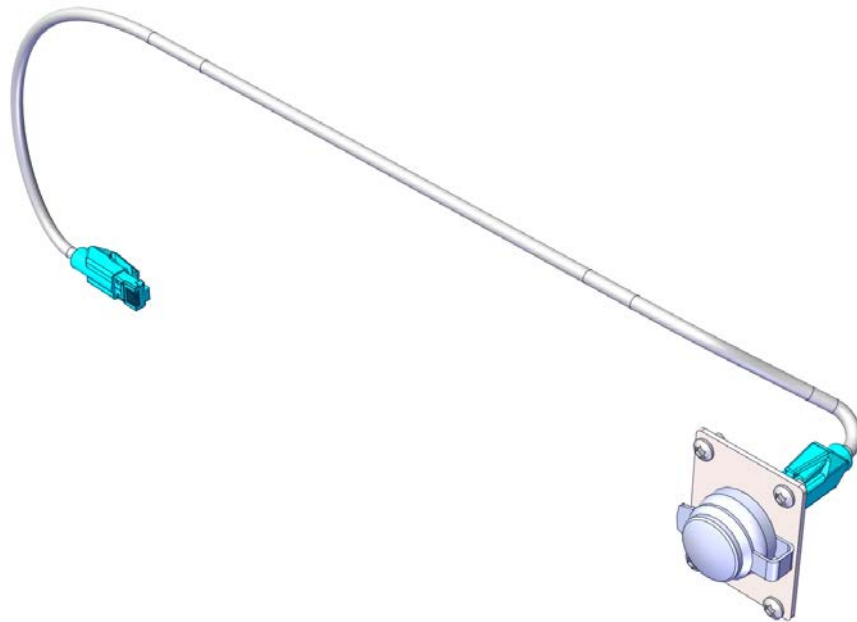

xx2100002585

	Spare part number	Description	Type	Spare part level
A	3HAC084151-001	Ethernet Harness		L1

**Harness TPU connection**

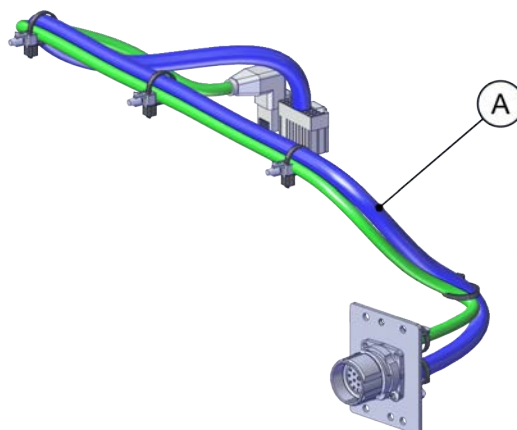

xx1900001943

Continues on next page

## 9 Spare parts

### 9.1.1 Controller system parts

Continued

	Spare part number	Description	Type	Spare part level
-	3HAC084134-001	Harness TPU connection		L1

### Harness motors power

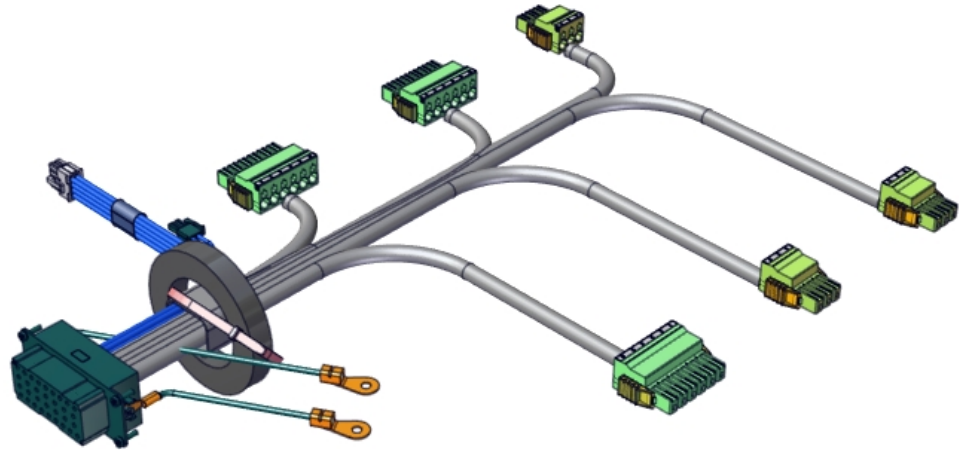

xx2100002496

	Spare part number	Description	Type	Spare part level
-	3HAC081696-001	Harness HV Manipulator Motor		L1
-	3HAC089244-001	Harness Manipulator Motor	Harness for IRB 2400	L1

### Harness ADU motors

	Spare part number	Description	Type	Spare part level
-	3HAC084159-001	Harness ADU Motors		L1
-	3HAC077969-001	Harn. 1xADU Motors		L1
-	3HAC083184-001	Harn. ADU Motors 4-6		L1

9.1.2 Mains connection parts

Mains power connection

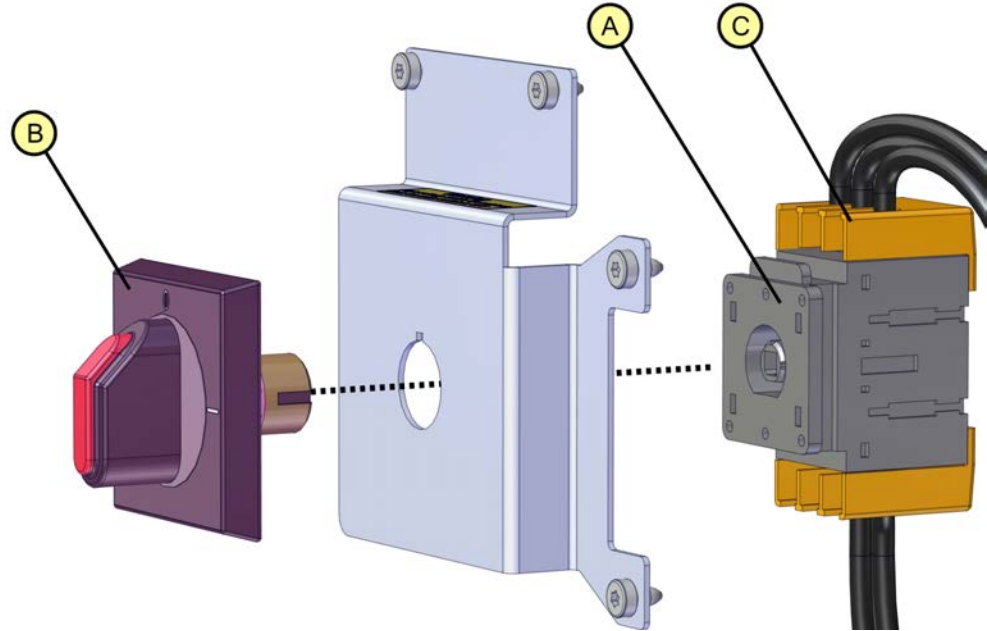

xx210000742

	Spare part number	Description	Type	Spare part level
A	3HAC022165-002	Mains switch		L1
B	3HAC026222-003	Handle for 6 mm switch		L1
C	3HAC073561-001	Terminal shrouds		L1
-	3HAC075871-001	Connector kit	For options 3008-2 Connector and 3008-3 Connector/fuse	L1
-	3HAC079544-001	Circuit breaker 32A 3p	For option 3008-3 Connector/fuse	L1
-	3HAC083284-001	Circuit breaker 16A 3p	For option 3008-3 Connector/fuse	L1

## 9 Spare parts

### 9.1.3 Logic parts

### 9.1.3 Logic parts

#### Main computer



xx230000669

	Spare part number	Description	Type	Spare part level
-	3HAC085504-001	Main computer Standard	DSQC1095	L1

*Continues on next page*

DeviceNet board

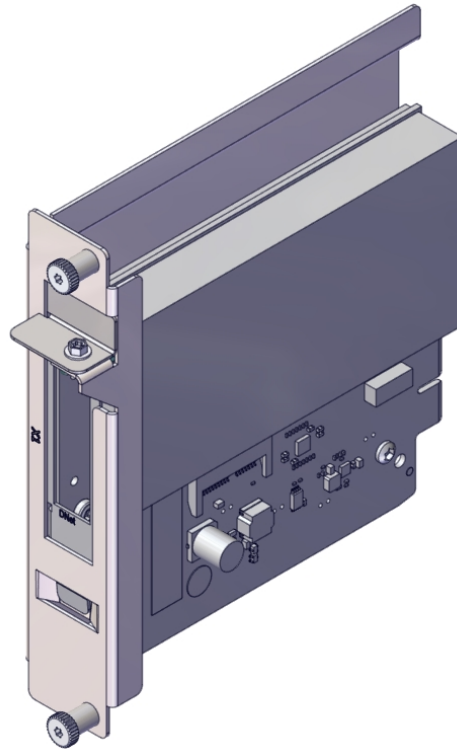

xx230000926

	Spare part number	Description	Type	Spare part level
A	3HAC085254-001	DeviceNet M/S [3029-1] (option)	DSQC1096	L1

Connected Services gateway

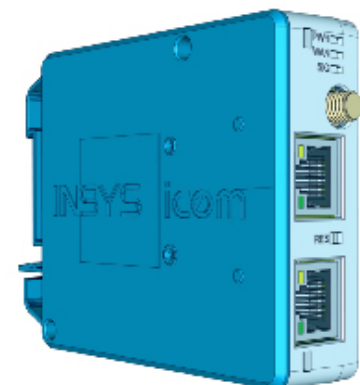
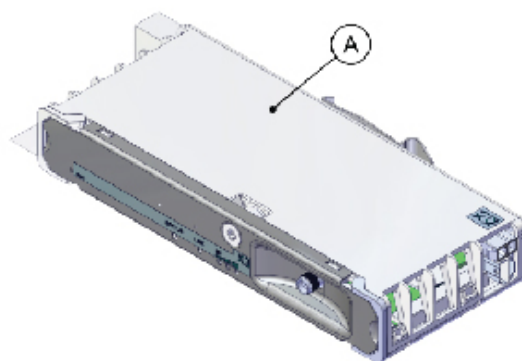

xx2300001645

	Spare part number	Description	Type	Spare part level
A	3HAC060960-001	Connected Services-3G [3013-3] (baseline)		L1
B	3HAC028459-001	Magnetic roof antenna, 3G (baseline)		L1

Continues on next page

## 9 Spare parts

---

### 9.1.3 Logic parts

*Continued*

	Spare part number	Description	Type	Spare part level
C	3HAC060962-001	Connected Services-WiFi [3013-2] (option)		L1
D	3HAC059424-001	Magnetic roof antenna, WiFi (option)		L1
E	3HAC061701-001	Connected Services-Wired [3013-1] (option)	DSQC1041	L1
-	3HAC086677-001	Connected Services 4G EU [3013-5] (option)	DSQC1093	L1
-	3HAC086678-001	Connected Services 4G US [3013-6] (option)	DSQC1093A	L1
-	3HAC086604-001	Magnetic roof antenna 4G (option)		L1



9.1.4 Application parts

CTM-01

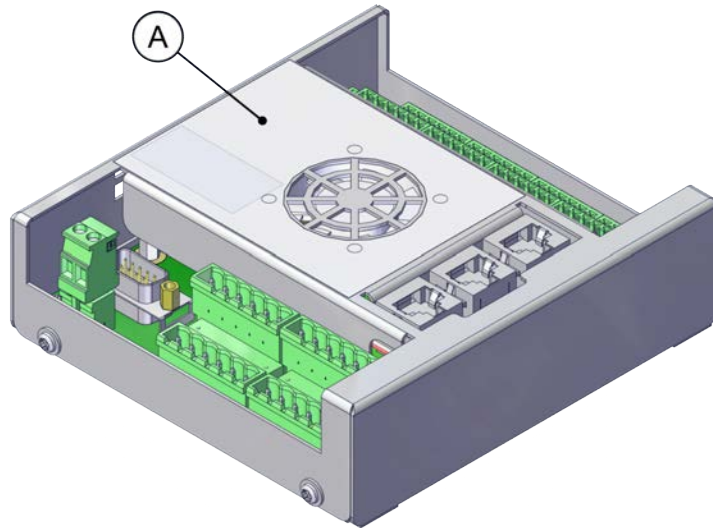

xx1900001938

	Spare part number	Description	Type	Spare part level
A	3HNA027579-001	Conveyor tracking module [3103-1]	DSQC2000	L1
-	3HNA029345-001	CONNECTOR KIT - DSQC2000		L1
-	3HAC084173-001	Harness 24V_CTM	Power cable of CTM	L1
-	3HAC084195-001	Ethernet harness for CTM		L1

Ethernet switches

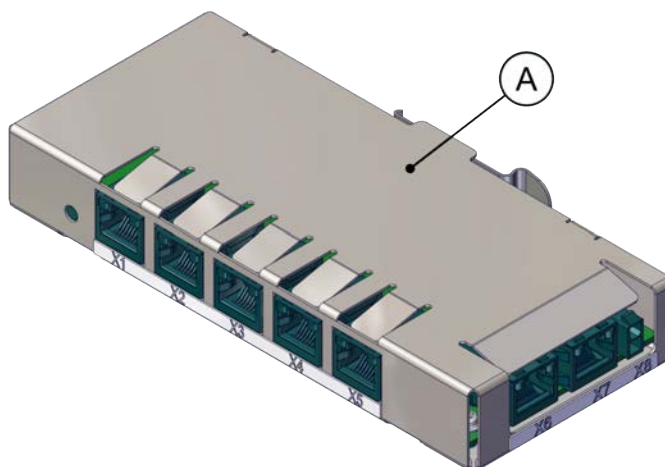

xx1900001935

Continues on next page

## 9 Spare parts

### 9.1.4 Application parts

Continued

	Spare part number	Description	Type	Spare part level
A	3HAC059187-001	Ethernet Extension switch [3014-1] (option)	DSQC1035	L1
-	3HAC084152-001	Ethernet Harness		L1

### Power supply device

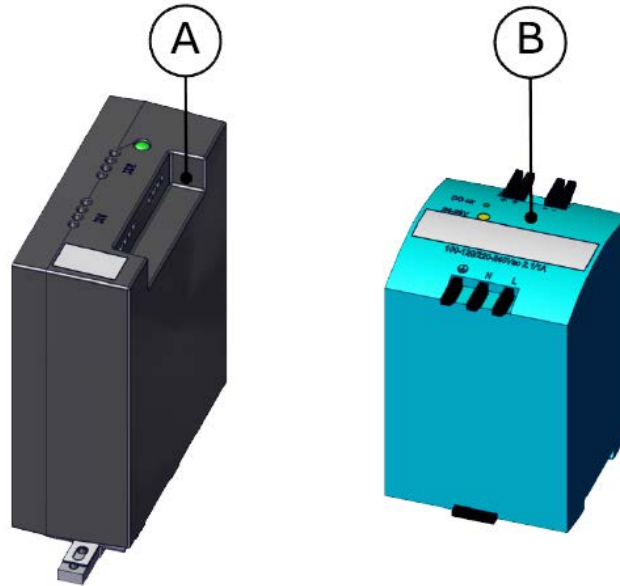

xx2100000740

	Spare part number	Description	Type	Spare part level
A	3HAC14178-1	DSQC 609 power supply	DSQC 609	L1
B	3HAC13398-2	DSQC 634 power supply	DSQC 634	L1

Continues on next page

Scalable I/O devices

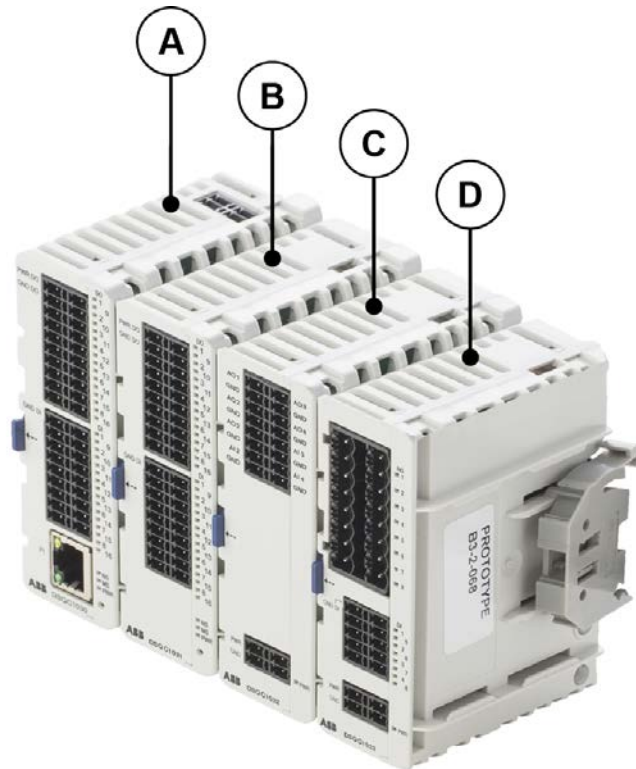

xx1900001939

	Spare part number	Description	Type	Spare part level
A	3HAC058663-001	Local I/O Digital base [3032-1] (option)	DSQC1030	L1
-	3HAC060919-001	Connectors digital base/add on		L1
B	3HAC058664-001	Digital add-on [3033-2] (Add-on)	DSQC1031	L1
C	3HAC058665-001	Analog add-on [3034-2] (Add-on)	DSQC1032	L1
-	3HAC060925-001	Connectors I/O Analog (Add-on)		L1
D	3HAC058666-001	Relay add-on [3035-2] (Add-on)	DSQC1033	L1
-	3HAC060926-001	Connectors I/O Relay (Add-on)		L1

Continues on next page

## 9 Spare parts

### 9.1.4 Application parts

Continued

#### Safety digital base device

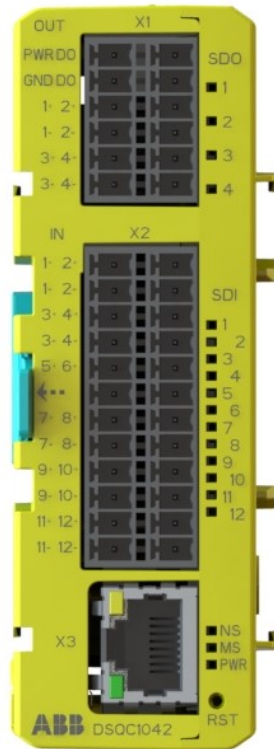

xx210000990

	Spare part number	Description	Type	Spare part level
-	3HAC062908-001	Safe I/O base unit		L1
-	3HAC069538-001	Connectors Safety I/O		L1

9.1.5 Cabinet parts

Fans

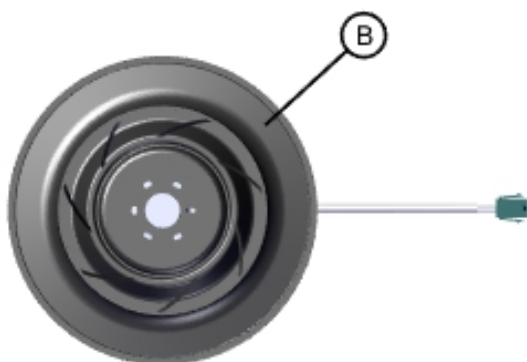
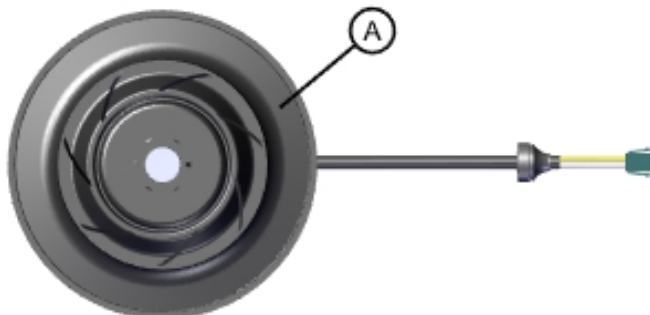

xx2200001093

	Spare part number	Description	Type	Spare part level
A	3HAC082805-001	Fan unit	External fan	L1
B	3HAC083027-001	Fan unit	Internal fan	L1

Main computer fan

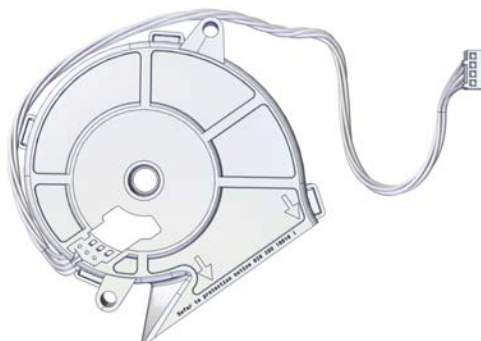

xx2300000925

Continues on next page

## 9 Spare parts

### 9.1.5 Cabinet parts

*Continued*

	Spare part number	Description	Type	Spare part level
-	3HAC084390-001	Fan w/ contact	Main computer fan	L1

#### Power unit fan



xx2100002283

	Spare part number	Description	Type	Spare part level
-	3HAC081496-001	Fan with connector	Power unit fan	L1

#### Process, fieldbus and I/O connectors

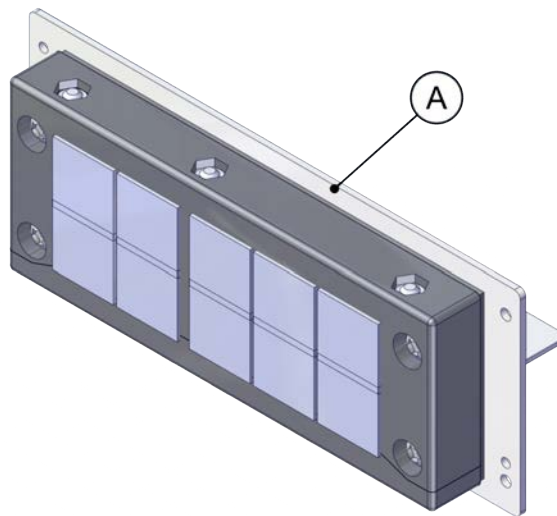

xx1900001928

*Continues on next page*

## 9 Spare parts

### 9.1.5 Cabinet parts

*Continued*

	Spare part number	Description	Type	Spare part level
A	3HAC066396-001	Cable grommet asm (option)		L1
B	3HAC084143-001	Harness CPCS	[3055-1] (option)	L1
C	3HAC069954-001	Blind plate		L1
D	3HAC084126-001	Harness DeviceNet		L1
-	3HAC079449-001	Cable gland process interface		L1

#### HMI panel

	Spare part number	Description	Type	Spare part level
-	3HAC077425-001	HMI panel		L1

#### Swing handle

	Spare part number	Description	Type	Spare part level
-	3HAC083816-001	Swinghandle with cam		L1

#### LED indicator

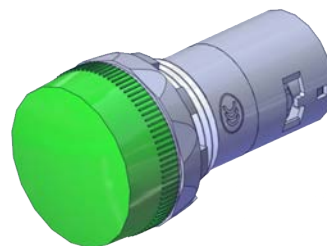

xx1900002451

	Spare part number	Description	Type	Spare part level
-	3HAC065549-001	LED indicator		L1

#### TPU cover



xx1900002452

*Continues on next page*

## 9 Spare parts

### 9.1.5 Cabinet parts

Continued

	Spare part number	Description	Type	Spare part level
-	3HAC067213-001	TPU cover		L1

### Air filter

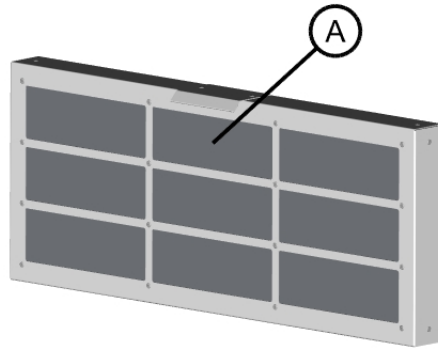

xx2200001828

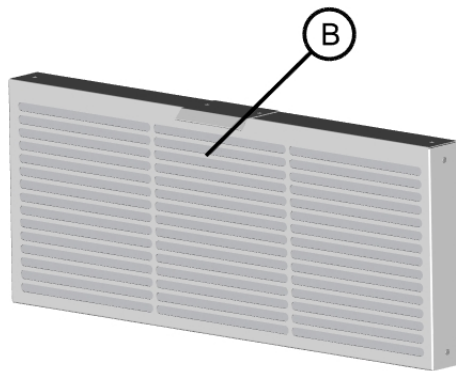

xx2200001826

	Spare part number	Description	Type	Spare part level
A	3HAC082548-001	Air filter coarse assembly		L1
B	3HAC082547-001	Air filter fine assembly		L1

### Cabinet door locks

Spare part number	Description	Type	Spare part level
3HAC074600-001	Key	Square 6 mm	L1
3HAC025309-004	Lock insert	Double bit 3	L1
3HAC025309-005	Lock insert	Slot 1, 2 x 3	L1
3HAC025309-007	Lock insert	Triangular 6,5 CNOMO	L1
3HAC025309-008	Lock insert	Cylinder E1	L1



## 9.1.6 Miscellaneous parts

## Manipulator signal connectors (SMB)



xx2200001954

	Spare part number	Description	Type	Spare part level
A	3HAC081735-001	Harness SMB connection		L1
-	3HAC077440-001	Harness SMB link	Harness 1xSMB	L1
-	3HAC077388-001	Harness SMB link	Harness 2xSMB	L1
-	3HAC086308-001	Harness SMB link	Harness 1xSMB	L1

*Continues on next page*

## 9 Spare parts

### 9.1.6 Miscellaneous parts

*Continued*

#### Harness CPCS



xx240000269

	Spare part number	Description	Type	Spare part level
A	3HAC084143-001	Harness CPCS	[3055-1] (option)	L1
B	3HAC089798-001	Harness CPCS	[3055-2] (option)	L1

*Continues on next page*

End clamp

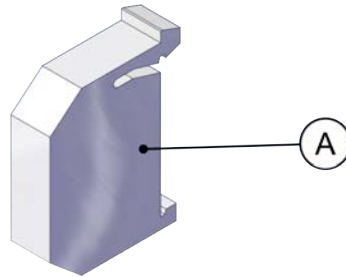

xx1900001940

	Spare part number	Description	Type	Spare part level
A	3HAB7983-1	End clamp		L1

Cable grommet asm

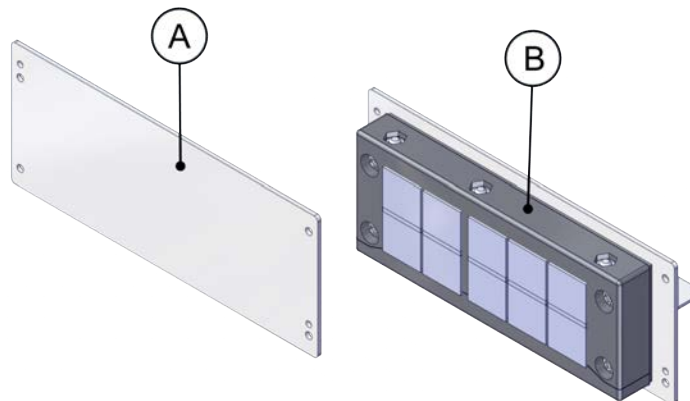

xx1900001947

	Spare part number	Description	Type	Spare part level
A	3HAC069954-001	Blind plate (baseline)		L1
B	3HAC066396-001	Cable grommet asm		L1
-	3HAC084125-001	Harness network connection 2xM12		L1
-	3HAC084103-001	Harness network connection 1xM12		L1
-	3HAC070894-001	Harness Ethernet comm. 5xM12		L1

Continues on next page

## 9 Spare parts

### 9.1.6 Miscellaneous parts

*Continued*

#### Vision parts

Spare part number	Description	Type	Spare part level
3HAC053944-001	8 mm camera lens, LTC-08F		L1
3HAC053944-002	12.5 mm camera lens, LFC-12.5F		L1
3HAC053944-003	16 mm camera lens, LFC-16F1		L1
3HAC053944-004	25 mm camera lens, LFC-25F1		L1
3HAC087266-001	8 mm camera lens, LMC-ML-M0822UR		L1
3HAC087267-001	12.5 mm camera lens, LMC-ML-M1218UR		L1
3HAC087268-001	16 mm camera lens, LMC-ML-M1616UR		L1
3HAC087269-001	25 mm camera lens, LMC-ML-M2516UR		L1
3HAC075182-001	Integrated Vision camera medium res	DSQC1063	L1
3HAC075207-001	Integrated Vision camera high res	DSQC1064	L1
3HAC087074-001	Integrated vision camera 2MPx	DSQC1098	L1
3HAC087075-001	Integrated vision camera 5MPx	DSQC1099	L1
3HAC051753-003	Integr Vision power cable 10 m		L1
3HAC075443-002	Integr Vision ethernet cable 10 m		L1
3HAC051753-004	Integr Vision power cable 15 m		L1
3HAC075443-003	Integr Vision ethernet cable 15 m		L1

#### Service port connector

Spare part number	Description	Type	Spare part level
3HAC064848-001	Service port connector		L1

*Continues on next page*

Motor connection box

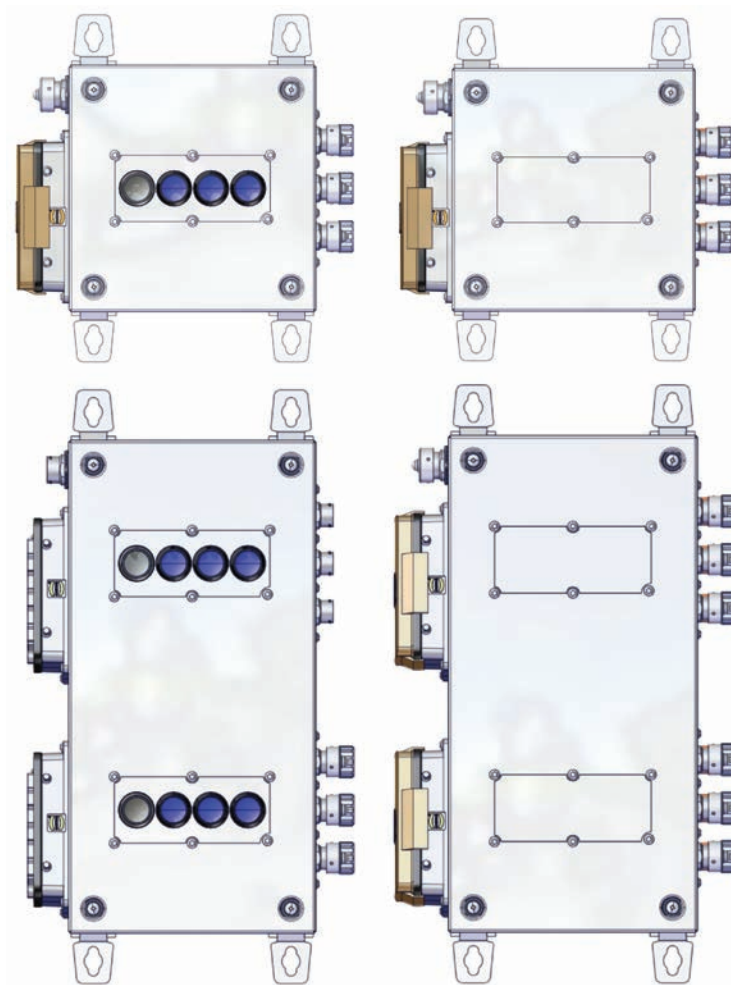

xx2300001671

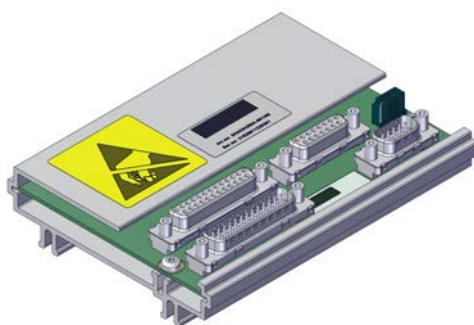

xx2300001699

	Spare part number	Description	Type	Spare part level
-	3HAC087717-001	Motor Connection Box	3-axis	L1
-	3HAC087718-001	Motor Connection Box	3-axis, BRB	L1
-	3HAC087719-001	Motor Connection Box	6-axis	L1

Continues on next page

## 9 Spare parts

### 9.1.6 Miscellaneous parts

Continued

	Spare part number	Description	Type	Spare part level
-	3HAC087720-001	Motor Connection Box	6-axis, BRB	L1
-	3HAC043904-001	Measurement Unit		L1
-	3HAC044075-001	Battery Unit		L1
-	3HAC078370-001	Ext. axis power harn._7m		L1
-	3HAC078370-002	Ext. axis power harn._15m		L1
-	3HAC078370-007	Ext. axis power harn._22m		L1
-	3HAC087715-001	Jumper plug PTC		L1

#### Dust ledge

Spare part number	Description	Type	Spare part level
3HAC088073-001	Dust ledge		L1

#### Dust Cap M12

Spare part number	Description	Type	Spare part level
3HAC073531-001	Dust Cap M12		L1

#### Door stop

Spare part number	Description	Type	Spare part level
3HAC083827-001	Door stop		L1

#### Extra cable jumpers

Spare part number	Description	Type	Spare part level
3HAC084243-001	Extra cable jumpers		L1

#### Wrist band

Spare part number	Description	Type	Spare part level
3HAB2997-1	Wrist band		L1

## 9.1.7 Cables

### Cables

#### Cables on the frame

	Spare part number	Description	Type	Spare part level
-	3HAC084058-001	Drive harness		L1
-	3HAC084054-001	Harn. 24V COOL		L1
-	3HAC084099-001	Harn. 24VDC_SYS		L1
-	3HAC084117-001	Harness MON_LAMP		L1
-	3HAC084124-001	Ethernet harness		L1
-	3HAC084141-001	Ethernet harness		L1
-	3HAC079051-001	Harness Short-circuit connector		L1

#### Cables on the drive unit

#### Cables on the high voltage drive unit

	Spare part number	Description	Type	Spare part level
-	3HAC065225-001	Harness DC-bus	Harness A1.X4 - T4.X5	L1
-	3HAC081734-001	Harness 24_SYS_DRV	Harness A1.X5 - T4.X1	L1
-	3HAC081970-001	Ethernet harness	Harness A1.X12 - T4.X3	L1
-	3HAC081731-001	Harness 24_BRAKE	Harness A1.X11 - T4.X13	L1
-	3HAC082738-001	Harness CTRL_FB	Harness A1.X2 - T4.X17	L1

#### Cables on the additional drive unit

	Spare part number	Description	Type	Spare part level
-	3HAC066724-001	Harn. Drive DC-bus	Harness A1.X8 - T41.X5	L1
-	3HAC074620-001	Harn. ADU_BRAKE	Harness A1.X14 - T41.X13	L1
-	3HAC077379-001	Ethernet harness	Harness T4.X4 - T41.X4	L1
-	3HAC077723-001	Harn. 24V_SYS_DRV	Harness T4.X2 - T41.X1	L1

*Continues on next page*

## 9 Spare parts

### 9.1.7 Cables

*Continued*

#### Cables on the Connected Services unit

	Spare part number	Description	Type	Spare part level
-	3HAC085903-001	Ethernet harness	Harness A2.K4.X1 - K7.ETH2	L1
-	3HAC085904-001	24V Adapter harness	Harness Adapter - K7.X1	L1

#### Cables on the power supply

	Spare part number	Description	Type	Spare part level
-	3HAC082083-001	Harness PSU 24V	DSQC 609 and DSQC 634	L1
-	3HAC082508-001	Harness PSU	DSQC 609 and DSQC 634	L1

#### Cables on the mains power connection

	Spare part number	Description	Type	Spare part level
-	3HAC082081-001	Harn. Mains connection		L1
-	3HAC081971-001	Harn. Mains connection		L1
-	3HAC077980-001	Harn. with ferrites		L1
-	3HAC082694-001	Harn. mains conn._fuse		L1



## 9.2 FlexPendant parts

## FlexPendant parts

The illustration below shows the placement of the parts in the recommended spare part list.

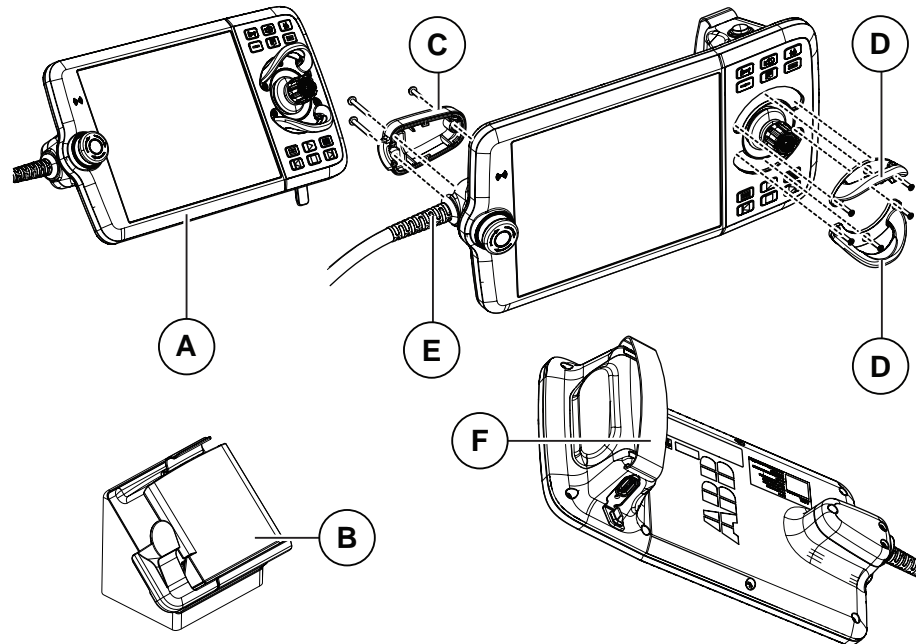

xx180000974

	Spare part number	Description	Type	Spare part level
A	3HAC086996-001	FlexPendant	DSQC3124	L1
B	3HAC079391-001	TPU Holder asm		L1
C	3HAC065401-001	Power cable cover		L1
D	3HAC065408-001	Joystick guard		L1
E	3HAC064448-002	FlexPendant power cable 3 m		L1
	3HAC064448-001	FlexPendant power cable 10 m		L1
	3HAC064448-003	FlexPendant power cable 30 m		L1
F	3HAC065419-001	Fasten strip		L1
-	3HAC068915-001	FlexPendant extension cable, 15 m		L1
-	3HAC068915-002	FlexPendant extension cable, 22 m		L1
-	3HAC068915-005	FlexPendant extension cable, 30 m		L1

## 9 Spare parts

### 9.3.1 Manipulator cables

## 9.3 Manipulator cables

### 9.3.1 Manipulator cables

#### Power cables

Cable length	Article number	Spare part level	Manipulator
Power cable 7 m	3HAC026787-001	L1	IRB 460, 660, 2600, 4600, 5710, 5720, 6650S, 6660, 6700, 67X0
Power cable 15 m	3HAC026787-002	L1	IRB 460, 660, 2600, 4600, 5710, 5720, 6650S, 6660, 6700, 67X0
Power cable 22 m	3HAC026787-003	L1	IRB 460, 660, 2600, 4600, 5710, 5720, 6650S, 6660, 6700, 67X0
Power cable 30 m	3HAC026787-004	L1	IRB 460, 660, 2600, 4600, 5710, 5720, 6650S, 6660, 6700, 67X0
Power cable 7 m	3HAC9038-1	L1	IRB 2400
Power cable 15 m	3HAC9038-2	L1	IRB 2400
Power cable 22 m	3HAC9038-3	L1	IRB 2400
Power cable 30 m	3HAC9038-4	L1	IRB 2400
Power cable 3 m	3HAC085288-007	L1	IRB 390
Power cable 7 m	3HAC085288-001	L1	IRB 390
Power cable 15 m	3HAC085288-002	L1	IRB 390
Power cable 22 m	3HAC085288-003	L1	IRB 390
Power cable 30 m	3HAC085288-004	L1	IRB 390

#### Signal cables

Cable length	Article number	Spare part level	Manipulator
Control cable signal 3 m	3HAC035320-001	L1	IRB 390
Control cable signal 7 m	3HAC2493-1	L1	IRB 390, 460, 2600, 4600, 5710, 5720, 67X0
Control cable signal 15 m	3HAC2530-1	L1	IRB 390, 460, 2600, 4600, 5710, 5720, 67X0
Control cable signal 22 m	3HAC2540-1	L1	IRB 390, 460, 2600, 4600, 5710, 5720, 67X0
Control cable signal 30 m	3HAC2566-1	L1	IRB 390, 460, 2600, 4600, 5710, 5720, 67X0
Control cable signal 7 m	3HAC7998-1	L1	IRB 660, 2400, 6650S, 6660
Control cable signal 15 m	3HAC7998-2	L1	IRB 660, 2400, 6650S, 6660
Control cable signal 22 m	3HAC7998-3	L1	IRB 660, 2400, 6650S, 6660
Control cable signal 30 m	3HAC7998-4	L1	IRB 660, 2400, 6650S, 6660

## 9.3.2 Customer cables - CP/CS connectors (option)

## CP/CS cables

Cable length	Article number	Spare part level	Manipulator
Cable CP/CS, 7 m	3HAC022957-001	L1	IRB 460, 660, 2600, 4600, 6650S, 6660, 6700
Cable CP/CS, 15 m	3HAC022957-002	L1	IRB 460, 660, 2600, 4600, 6650S, 6660, 6700
Cable CP/CS, 30 m	3HAC022957-003	L1	IRB 460, 660, 2600, 4600, 6650S, 6660, 6700
Cable CP/CS, 7 m	3HAC083786-001	L1	IRB 2400
Cable CP/CS, 15 m	3HAC083786-002	L1	IRB 2400
Cable CP/CS, 22 m	3HAC083786-003	L1	IRB 2400
Cable CP/CS, 30 m	3HAC083786-004	L1	IRB 2400
Cable CP/CS, 40 m	3HAC083786-005	L1	IRB 2400
Cable CP/CS, 7 m	3HAC089711-001	L1	IRB 5710, 5720, 6710, 6720, 6730, 6740
Cable CP/CS, 15 m	3HAC089711-002	L1	IRB 5710, 5720, 6710, 6720, 6730, 6740
Cable CP/CS, 22 m	3HAC089711-003	L1	IRB 5710, 5720, 6710, 6720, 6730, 6740
Cable CP/CS, 30 m	3HAC089711-004	L1	IRB 5710, 5720, 6710, 6720, 6730, 6740

## 9 Spare parts

---

### 9.3.3 Customer cables - Ethernet floor cables

### 9.3.3 Customer cables - Ethernet floor cables

---

#### Ethernet floor cables (option)

Cable length	Article number	Spare part level	Manipulator
Ethernet floor cable, 7 m	3HAC079476-001	L1	IRB 460, 660, 2600, 4600, 5710, 5720, 6650S, 6660, 6700, 67X0
Ethernet floor cable, 15 m	3HAC079476-002	L1	IRB 460, 660, 2600, 4600, 5710, 5720, 6650S, 6660, 6700, 67X0
Ethernet floor cable, 30 m	3HAC079476-004	L1	IRB 460, 660, 2600, 4600, 5710, 5720, 6650S, 6660, 6700, 67X0

**9.3.4 Customer cables - DeviceNet cables****DeviceNet floor cables (option)**

Cable length	Article number	Spare part level	Manipulator
Cable CP/CS DeviceNet, 7 m	3HAC022978-001	L1	IRB 460, 660, 2600, 4600, 6650S, 6660, 6700
Cable CP/CS DeviceNet, 15 m	3HAC022978-002	L1	IRB 460, 660, 2600, 4600, 6650S, 6660, 6700
Cable CP/CS DeviceNet, 30 m	3HAC022978-003	L1	IRB 460, 660, 2600, 4600, 6650S, 6660, 6700

**This page is intentionally left blank**

# Index

## 3

3rd party software, 49

## 4

4G, 221

## A

additional drive unit  
installing, 126  
LED, 386  
replacing, 272  
test equipment, 387  
troubleshooting, 384  
troubleshooting flowchart, 388

ADU, 272, 384

installing, 126

allergenic material, 28

aluminum

disposal, 350

ambient temperature

operation, 39

storage, 39

## AS

configuring, 108

assembly instructions, 53

assessment of hazards and risks, 28

automatic mode, 27

automatic stop, 108

function test, 181

## B

batteries

disposal, 350

bolt pattern, 60

brake current, 389

brakes not releasing, 363

brominated flame retardants

disposal, 350

## C

cabinet lock, 29

cables, 81

carbon dioxide extinguisher, 29

category 0 stop, 21

category 1 stop, 21

cleaning

FlexPendant, 47

cleaning of the controller, 170

cleaning the FlexPendant, 171

climbing on robot, 32

Connected Services gateway

replacing, 214, 221

Connected Services Gateway

LED, 406, 412

test equipment, 407, 413

troubleshooting flowchart, 408, 413

connection

manipulator cables, 81

controller

symbols, 18

controller fails to start, 371

controller mode, 371

cooling fan

replacing, 193

copper

disposal, 350

## D

damaged bearings, 373

damaged parallel bar, 373

detaching FlexPendant, 87

DeviceNet, 276

installing, 154

dimensions, 39

disconnecting FlexPendant, 87

disposal of storage media, 349

drive unit

LED, 379

replacing, 267

test equipment, 380

troubleshooting flowchart, 381

## E

earth fault protection, 84

emergency stop, 21

function test, 177

emergency stops, 23

enabling device, 24

function test, 179

EN ISO 13849-1, 14

environmental information, 350

ESD

damage elimination, 45

sensitive equipment, 45

esd elimination, 46

Ethernet

installing, 123

Ethernet extension switch

installing, 123

Ethernet switch

LED, 423

replacing, 210

Ethernet switch board

connectors, 95

external I/O

installing, 117

replacing, 229

## F

fan

replacing, 193

faulty calibration, 373

faulty TCP definition, 373

fire extinguishing, 29

firmware, reflashing failure, 372

FlexPendant

blue screen, 366

cleaning, 47

connecting, disconnecting, 87

storage, 47

FlexPendant connector, 140, 146, 285, 302, 308

FlexPendant holder, 61

FlexPendant joystick not working, 370

FlexPendant not responding, 366

FlexPendant not starting, 366

function tests, 177

## G

general stop, 108, 182

GS

configuring, 108

## H

- hanging
  - installed hanging, 28
- hazard levels, 16
- hazardous material, 350
- height
  - installed at a height, 28
- hold-to-run, 24
- hot surfaces, 32
- HRA, 28

## I

- I/O connectors, 105
- industrial network, 114
- installation activities, 54
- installation space, 58
- instructions for assembly, 53
- integrator responsibility, 28
- internal I/O
  - installing, 117
  - replacing, 229

## J

- jogging not possible, 370
- joystick not working, 370

## K

- key of the mode switch, 31

## L

- labels
  - controller, 18
- lead
  - disposal, 350
- LED
  - additional drive unit, 386
  - Connected Services Gateway, 406, 412
  - drive unit, 379
  - Ethernet switch, 423
  - main computer, 425
  - power unit, 392, 399
- LEDs , indication, 356
- LEDs not lit, 356
- licenses, 49
- lifting device, 55
- limitation of liability, 13
- Lithium
  - disposal, 350
- lock and tag, 29

## M

- main computer
  - replacing, 238
- main power supply, 106
- maintenance schedule, 165
- manipulator cables, 81
- manual full speed mode, 25
- manual high speed mode, 25
- manual mode, 25
- manual reduced speed, 25
- mode switch key, 31
- motor contactors
  - function test, 180
- MTTF<sub>D</sub>, 14

## N

- national regulations, 28

- network security, 48
- noise, 373
- normal operation mode, 371

## O

- ODVA, 431
- ODVA power supply
  - LED, 431
- open source software, OSS, 49
- operating conditions, 39
- operating mode
  - automatic mode, 27
  - function test, 178
  - manual full speed mode, 25
  - manual mode, 25
  - manual reduced speed, 25
- optional power supply
  - installing, 131
- original spare parts, 13

## P

- path accuracy, 373
- pedestal
  - installed on pedestal, 28
- performance level, PL, 14
- personnel
  - requirements, 15
- PFH<sub>D</sub>, 14, 43–44
- PL, performance level, 14
- plastic
  - disposal, 350
- power distribution board
  - connectors, 92
- power failure during start-up, 359
- power supply, 430–431
  - replacing, 259
- power supply optional
  - installing, 131
- power unit
  - LED, 392, 399
  - replacing, 249
  - test equipment, 393, 400
  - troubleshooting flowchart, 394, 401
- PPE, 15
- problem releasing the robot brakes, 363
- processor board
  - connectors, 94
- process power supply, 430
  - DC OK, 430
  - LED, 430
- product standards, 434
- protection classes, 40
- protection type, 40
- protective earth, 85
- protective equipment, 15
- protective stop
  - definition, 21
- protective wear, 15

## R

- RCD, 84
- recovering from emergency stops, 23
- recycling, 350
- reduced speed control
  - function test, 185
- reflashing firmware failure, 372
- regional regulations, 28



- remote I/O
  - installing, 117
  - replacing, 229
- replacements, report, 187
- report replacements, 187
- required performance level, PLr, 14
- residual current device, 84
- responsibility and validity, 13
- risk of burns, 32
- robot
  - protection class, 40
  - protection types, 40
- RobotWare Installation Utilities mode, 371
- rubber
  - disposal, 350
- S**
- safeguarding, 21
- safeguard mechanisms
  - automatic mode, 27
  - manual mode, 25
- safety
  - ESD, 45
  - fire extinguishing, 29
  - signals, 16
  - signals in manual, 16
  - stop functions, 21
  - symbols, 16
  - symbols on controller, 18
- safety board
  - connectors, 96
- safety devices, 29
- safety digital base
  - install, 120
  - replacing, 234
- safety signals
  - in manual, 16
- safety standards, 434
- scalable I/O, 116
  - connectors, 105
  - installing, 117
  - replacing, 229
- scalable I/O external, 116
- scalable I/O internal, 116
- shipping, 349
- signals
  - safety, 16
- sim card
  - replacing, 214
- software licenses, 49
- standards, 434
- steel
  - disposal, 350
- stop category 0, 21
- stop category 1, 21
- stops
  - overview, 21
- storage conditions, 39
- switch
  - Ethernet Extension, 123
- symbols
  - safety, 16
- system integrator requirements, 28
- system update failure, 362
- T**
- teach pendant
  - detach, attach, 87
- temperatures
  - operation, 39
  - storage, 39
- three-position enabling device, 24
  - function test, 179
- tightening torque, 437
- TPU
  - connecting, disconnecting, 87
- transportation, 349
- transportation conditions, 39
- troubleshooting
  - safety, 33
- U**
- upcycling, 350
- users
  - requirements, 15
- V**
- validity and responsibility, 13
- W**
- warranty, 414
- weight, 39
- wrist strap, 46
- X**
- X45 IP20, 106







**ABB AB**

**Robotics & Discrete Automation**

S-721 68 VÄSTERÅS, Sweden

Telephone +46 10-732 50 00

**ABB AS**

**Robotics & Discrete Automation**

Nordlysvegen 7, N-4340 BRYNE, Norway

Box 265, N-4349 BRYNE, Norway

Telephone: +47 22 87 2000

**ABB Engineering (Shanghai) Ltd.**

Robotics & Discrete Automation

No. 4528 Kangxin Highway

PuDong New District

SHANGHAI 201319, China

Telephone: +86 21 6105 6666

**ABB Inc.**

**Robotics & Discrete Automation**

1250 Brown Road

Auburn Hills, MI 48326

USA

Telephone: +1 248 391 9000

**[abb.com/robotics](http://abb.com/robotics)**